

Spreaders

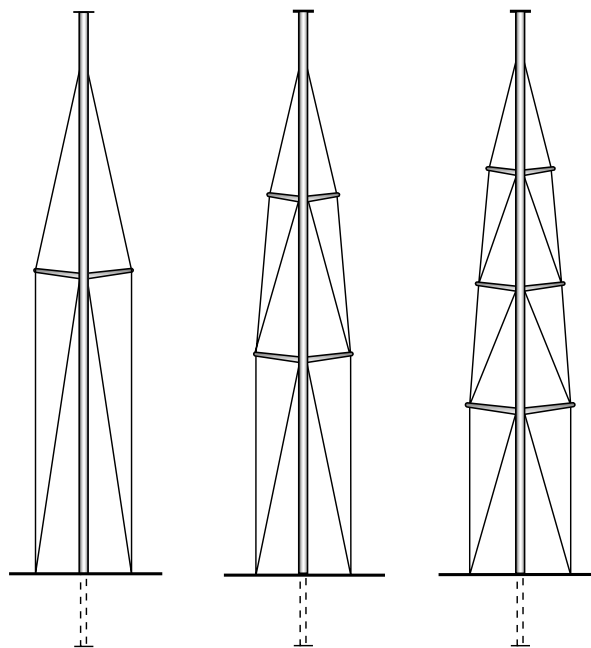

Seldén T-spreaders for C-sections and F-sections.



Single spreaders.

Double spreaders.

Triple spreaders.

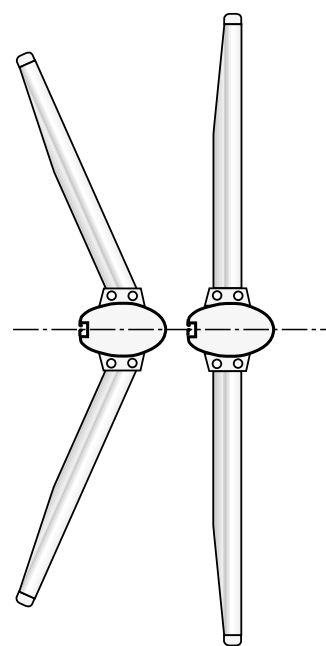

Swept.

In-line.



The C-section's and F-section's spreader fitting is a through-mast design which provides strength as well as a smooth and elegant appearance. The shroud fittings for the lower or middle shrouds are integrated into the spreader attachment. This reduces the number of fittings on the mast, and keeps weight down.

Spreader ends

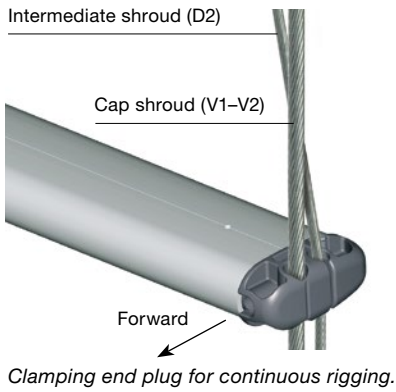

The design of the spreader ends varies with rig type, the number of spreaders, and whether the lateral rigging is linked or continuous.

Spreader end for linked lateral rigging on 30-70 ft yachts

- Minimal distance from shroud to edge of spreader end. Makes for improved jib trim. Jib can be sheeted close to shroud.
- Large, smooth surface. Gentle on the sail. No tape required.
- No split pins to catch sails or halyards.
- Works with both wire and rod rigging featuring stemball terminals.
- Few parts. Easy to assemble.
- Vertical and diagonal loads well balanced in spreader end. Makes for less stress throughout spreader assembly.
- Lighter than tip-cup versions and most other comparable spreader ends.
- Cast stainless steel, AISI316.

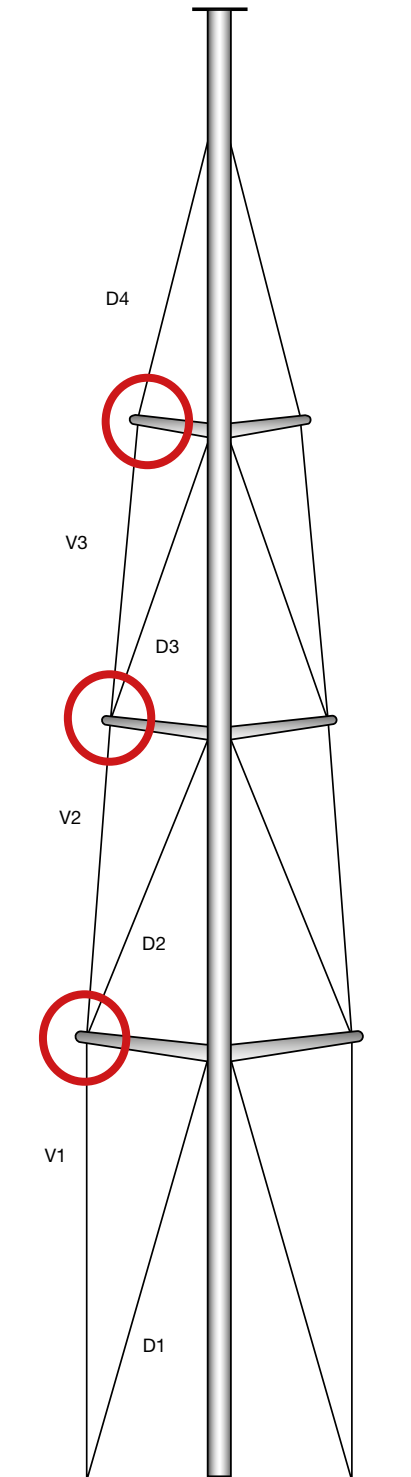

How to order new spreaders



The easiest way to order new spreaders for your mast is to provide one of our dealers with the mast ID-number engraved in to the lower end of the mast section. If this ID-number is inaccessible, the following procedure will do.

- What mast section is it for? Measure the mast longitudinal and athwartships (mm) and compare with sections listed at page 10. For masts produced earlier than 2002 (E, D, R and P sections), see Version 6 of our catalogue, www.seldenmast.com.
- What spreader fitting? You will find a part number on the fitting.
- What length? Measure the length of the front edge of the spreader from inner end to outer end, excluding the end plug (L).
- Starboard or port spreader? We recommend you to order a complete pair as this will ensure that both spreaders have the same angle.
- For a multi spreader rig, what spreader do you need (lower, intermediate or upper)?
- What angle? Provide us with L and S and we will calculate the angle.

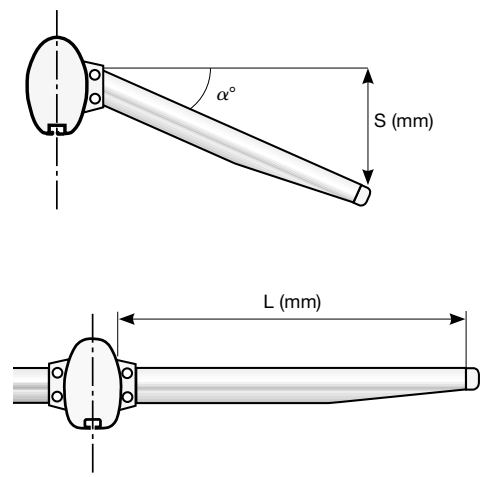

Spreader brackets and spreader assemblies

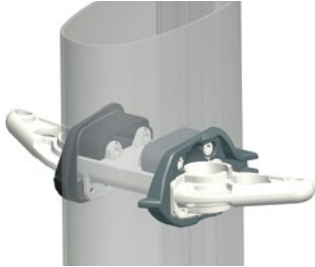

Spreader brackets,
C156-C193, F176-F212.



Spreader brackets,
C211-C304, F212-F305.

Mast section	Bracket pair starboard and port	Spreader width, mm	Length, mm (taper)	Spreader Assembly Art. No. (1 pair) incl. Clevispins, excl. End plugs	Clamping end plug (1 pc)
C137	522-224-01	T-74	400 (400)	503-667-01	Wire ø 5
C153	522-226-01		450	503-668-01	500-650-01
			500	503-669-01	
			550	503-670-01	Wire ø 7
			600	503-671-01	500-651-01
			650	503-672-01	
			700 (500)	503-673-01	
			750	503-674-01	
			800	503-675-01	
			850	503-676-01	
			900	503-677-01	
			950 (750)	503-678-01	
			1000	503-679-01	
			1050	503-680-01	
			1100	503-681-01	
			1150	503-682-01	
			1200	503-683-01	
			1250 (1150)	503-684-01	
			1300	503-685-01	
			1350	503-686-01	
			1400	503-687-01	
			1450	503-688-01	
			1500	503-689-01	
C156	522-108-01	T-90	600 (550)	503-242-01/-11	Wire ø 4-5
C175	522-109-01		650	503-243-01/-11	500-636-01
C193	522-110-01		700	503-244-01/-11	
C211	522-216-01		750	503-245-01/-11	Wire ø 6-8
C227	522-217-01		800 (700)	503-246-01/-11	500-640-01
C245	522-218-01		850	503-247-01/-11	
F176	522-255-01		900	503-248-01/-11	Wire ø10
F194	522-255-02		950	503-249-01/-11	500-820-01
F212	522-255-03		1000 (900)	503-250-01/-11	
F228	522-255-04		1050	503-251-01/-11	
F246	522-255-05		1100	503-252-01/-11	
			1150	503-253-01/-11	
			1200	503-254-01/-11	
			1300 (1000)	503-255-01/-11	
			1600 (1200)	503-256-01/-11	
			1750	503-257-01/-11	

Mast section	Bracket pair starboard and port	Spreader width, mm	Length, mm (taper)	Spreader Assembly Art. No. (1 pair) incl. Clevispins, excl. End plugs	Clamping end plug (1 pc)
C211	522-116-11	T-105	600 (450)	503-341-01/-02/-11	Wire ø 6
C227	522-116-13		650 (600)	503-342-01/-02/-11	500-589-01
C245	522-116-15		700	503-343-01/-02/-11	
C264	522-116-21		750	503-344-01/-02/-11	Wire ø 7-8
C285	522-116-23		800	503-345-01/-02/-11	500-590-01
C304	522-116-25		850 (750)	503-346-01/-02/-11	
F212	522-253-01		900	503-347-01/-02/-11	Wire ø 10
F228	522-253-02		950	503-348-01/-02/-11	500-591-01
F246	522-253-03		1000	503-349-01/-02/-11	
F265	522-253-04		1050	503-350-01/-02/-11	Wire ø 12
F286	522-253-05		1100	503-351-01/-02/-11	500-821-01
F305	522-253-06		1150 (1000)	503-352-01/-02/-11	
			1200	503-353-01/-02/-11	
			1300	503-354-01/-02/-11	
			1400	503-355-01/-02/-11	
			1500	503-356-01/-02/-11	
			1600	503-357-01/-02/-11	
			1750 (1200)	503-358-01/-02/-11	
			1850 (1400)	503-359-01/-02/-11	
			2100	503-360-01/-02/-11	
C264	522-122-11	T-131	600 (550)	503-460-01/-02/-11	Wire ø 6-7
C285	522-122-13		650 (600)	503-461-01/-02/-11	500-700-01
C304	522-122-15		700	503-462-01/-02/-11	
C321	522-122-31		750	503-463-01/-02/-11	Wire ø 8-10
C365	522-122-33		800	503-464-01/-02/-11	500-701-01
F265	522-257-01		850 (800)	503-465-01/-02/-11	
F286	522-257-02		900	503-466-01/-02/-11	Wire ø 12
F305	522-257-03		950	503-467-01/-02/-11	500-702-01
F324	522-257-04		1000	503-468-01/-02/-11	
F370	522-257-05		1050	503-469-01/-02/-11	Wire ø 14
F406	522-257-06		1100	503-470-01/-02/-11	500-703-01
			1150 (1100)	503-471-01/-02/-11	
			1200	503-472-01/-02/-11	
			1250	503-473-01/-02/-11	
			1300	503-474-01/-02/-11	
			1350	503-475-01/-02/-11	
			1400	503-476-01/-02/-11	
			1450	503-477-01/-02/-11	
			1500	503-478-01/-02/-11	
			1600	503-480-01/-02/-11	
			2100	503-481-01/-02/-11	
			2500	503-482-01/-02/-11	

* Compression bar to be used only if diagonal shroud is attached via fitting in mast wall (as opposed to attachment in spreader bracket).

-01 = With cut-out for stemball
-02 = Without cut-out for stemball
-11 = T-spreaders for F-section

Spreader end plugs, linked rig

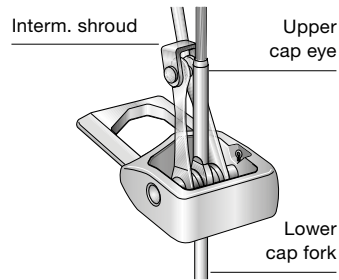

Linked end plug (prior to 2008).



Linked end plug for stemball terminals (from 2008).

Spreader width, mm dia., mm	Upper cap eye dia., mm	Lower cap eye dia., mm	Interm. shroud		Art. No. Prior to 2008	Remarks	Linked end plug for stemball terminals
			Rigging screw dimension	Wire dia., mm			
T-74	7	7	3/8"	5			500-992-01
							Seat radius R11
T-90	5	5	1/4"	3-4	500-637-10		500-998-01
	5	5	5/16"	4-5	500-637-04		
	5	6	1/4"	3-4	500-637-12		
	5	6	5/16"	4-5	500-637-06		
	6-7	6-7	1/4"	3-4	500-637-11	Fork ø6: Use 308-417 (ø12,5 mm hole)	
	6-7	6-7	5/16"	4-5	500-637-05	Fork ø6: Use 308-417 (ø12,5 mm hole)	
	6-7	6-7	3/8"	5-6	500-637-01	Fork ø6: Use 308-417 (ø12,5 mm hole)	
	7	8	5/16"	4-5	500-637-07		
	7	8	3/8"	5-6	500-637-08		
	7	8	7/16"	6-7	500-637-02		500-998-10
	8	8-10	3/8", 5/16"	5-6	500-637-09		
	8	8-10	7/16"	6-7	500-637-03		
T-105	7	7	5/16", 3/8"	5-6	500-555-09		500-998-10
	7	8	5/16", 3/8"	5-6	500-555-05		Seat radius R14/R14/R11
	7	8	7/16"	6-7	500-555-01		
	8	8	3/8", 7/16"	5-7	500-555-04		
	8-10	10	3/8", 7/16"	5-7	500-555-08		
	8-10	10	1/2"	7-8	500-555-02		
	10	12	7/16"	6-7	500-555-07		
	10	12	1/2"	7-8	500-555-03		
	12	12	5/8"	7-10	500-555-06		500-996-01
							Seat radius R18/R18/R11
T-131	8	8	3/8", 7/16"	5-7	500-704-13		500-996-10
	8-10	10	3/8", 7/16"	5-7	500-704-10	Fork ø10: Drill ø12,5 mm hole	Seat radius R18/R18/R11
	8-10	10	1/2"	7-8	500-704-01	Fork ø10: Drill ø12,5 mm hole	
	8-10	12	7/16", 1/2"	7-8	500-704-02		
	8-10	12	5/8"	8-10	500-704-12		
	12	12	1/2"	7-8	500-704-06		
	12	12-14	5/8"	8-10	500-704-05		
	12	14	1/2"	7-8	500-704-07		
	12	14	3/4"	10-12	500-704-03		
	14	14	5/8"	8-10	500-704-14		500-994-01
	14	14	3/4"	10-12	500-704-08		Seat radius R22/R22/R14
	14	16	5/8"	8-12	500-817-01		

Stemball terminals for spreader brackets

Stemball terminals

The lower shrouds and intermediate shrouds hanging in the spreader brackets have a stemball terminal at the upper end. This terminal is located in the cup of the spreader bracket. If required, it can be used with one or two separate cups to bring it up to the correct size for the cup. Measure the width of the complete assembly, including any cups, to ensure that all the cups are in position.



Mast section	Spreader width, mm	Total width of stemball incl. any cups, mm	Wire diameter, mm						
			Art. No. Ø 4 mm	Art. No. Ø 5 mm	Art. No. Ø 6 mm	Art. No. Ø 7 mm	Art. No. Ø 8 mm	Art. No. Ø 10 mm	Art. No. Ø 12 mm
C137 C153	T-74	27.6	308-558-01	308-552-01	308-553-01	308-554-01	308-555	308-556	-
C156 C175	T-90		(T+C+C)	(T+C+C)	(T+C)	(T+C)	(T)	(T)	
C193 C211	T-105								
C227 C245									
C264 C285	T-131	35.6	-	-	308-553-02	308-554-02	308-555-02	308-556-02	308-557
C304					(T+C+C)	(T+C+C)	(T+C)	(T+C)	(T)

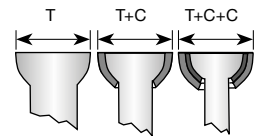

T = Terminal (Stemball)
T+C=Terminal + Cup
T+C+C=Terminal + 2 Cups

Wire diameter, mm	Art. No. Terminal+cups (radius)	Art. No. Terminal (radius)	Art. No. Cups (inner/outer radius)	Art. No. Cups (inner/outer radius)
3	308-550-03 (R9)	308-550 (R6)	306-594 (R6/9)	-
	308-550-04 (R11)			306-572 (R9/11)
4	308-558 (R9)	308-558 (R9)	-	-
	308-558-04 (R11)		306-572 (R9/11)	-
	308-558-01 (R14)			306-573 (R11/14)
5	308-552 (R9)	308-552 (R9)	-	-
	308-552-04 (R11)		306-572 (R9/11)	-
	308-552-01 (R14)			306-573 (R11/14)
6	308-553 (R11)	308-553 (R11)	-	-
	308-553-01 (R14)		306-573 (R11/14)	-
	308-553-02 (R18)			306-574 (R14/18)
7	308-554 (R11)	308-554 (R11)	-	-
	308-554-01 (R14)		306-573 (R11/14)	-
	308-554-02 (R18)			306-574 (R14/18)
8	308-555 (R14)	308-555 (R14)	-	-
	308-555-02 (R18)		306-574 (R14/18)	-
	308-555-05 (R22)			306-595 (R18/22)
10	308-556 (R14)	308-556 (R14)	-	-
	308-556-02 (R18)		306-574 (R14/18)	-
	308-556-05 (R22)			306-595 (R18/22)
12	308-557 (R18)	308-557 (R18)	-	-
	308-557-05 (R22)		306-595 (R18/22)	-
14	308-559 (R22)	308-559 (R22)	-	-

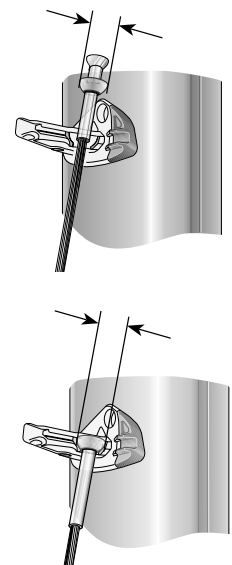

T-spreaders, clevis pins and split pins for spreader brackets

Spreader width, mm	Clevis pin Art. No. (dim., mm)	Split pin Art. No. (dim., mm)
T-74	165-203 (ø10 x 28)	301-049 (ø2,9 x 16)
T-90	165-402 (Ø 12 x 33)	301-049 (Ø 2,9 x 16)
T-105	165-505 (Ø 14 x 41)	301-053 (Ø 3,7 x 20)
T-131	165-552 (Ø 16 x 50)	301-051 (Ø 3,7 x 25)