

Manual Hydraulic backstay tensioner HT

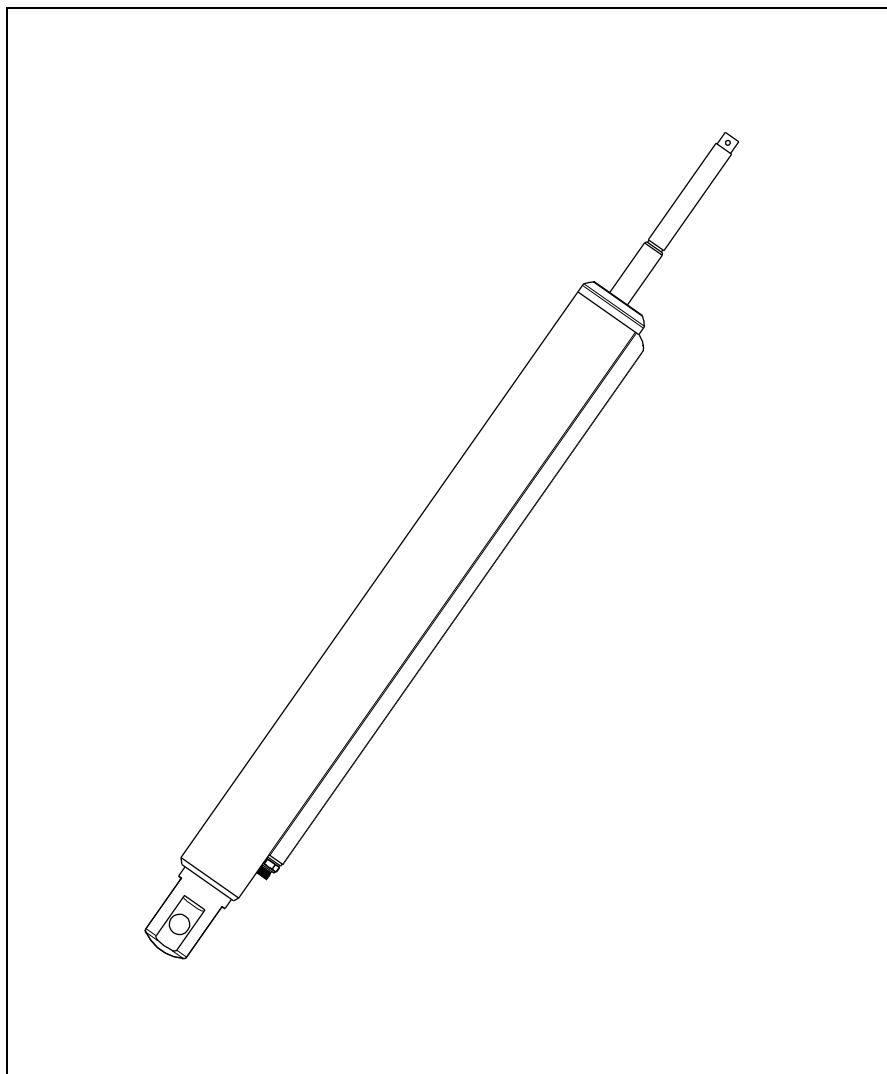

General / The manual

To derive the maximum benefit and enjoyment from your Seldén Backstay tensioner, we recommend that you study this manual carefully.

Selden limited warranty applies to this product. For full details please see our general conditions of sale.

The guarantee is only valid if the tensioner is installed and operated in accordance with this manual.

If the tensioner is repaired by anyone not authorized by Seldén Mast AB, the guarantee ceases to be valid.

Seldén Mast AB reserves the right to alter the content of the manual and design of the product without prior warning.

For latest update check www.seldenmast.se or contact Seldén for your own issue.



This symbol denotes safety related information

Please follow Selden 595-540-E “Hints and Advice” on rigging and tuning masts.

Product Description / Information

The Selden Backstay Tensioner is intended for use on a sailing boat for tensioning the backstay.

It is intended to be connected to a hydraulic system that has a pump, a release valve and a holding tank.

When pressurized oil is pumped into the tensioner it will contract and act with a pulling force on the backstay.

When the pressure is released by the release valve oil will flow from the tensioner back into the tank as the tensioner is extended by the backstay.

Technical data

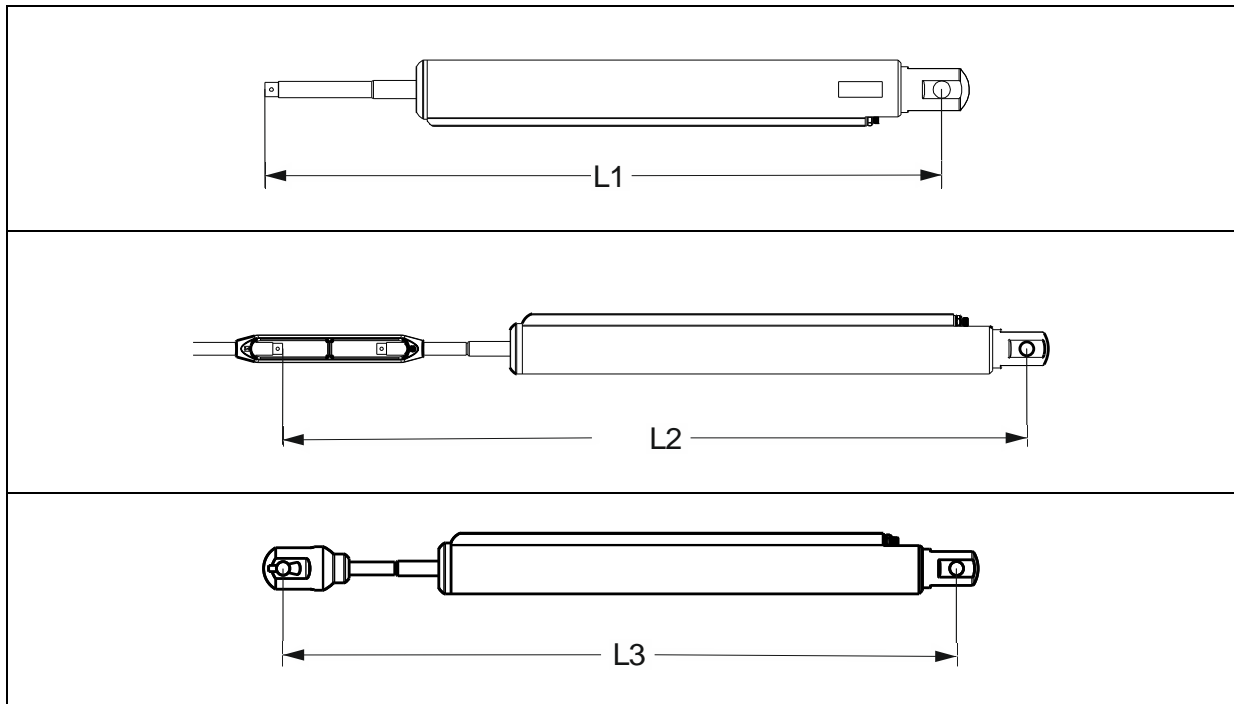

	HT-W8/10	HT-W12/14
Safe working load [kN]	44	85
Cylinder outer diameter [mm]	62	80
Weight [kg]	5,5	12
Hole Upper / Lower [mm]	ø12.5	ø16.5
Pin Upper / Lower [mm]	Ø12	ø16
Fork Width X Upper / Lower	14 / 21	16 / 16
Fork Depth Z Upper / Lower	30 / 22	34 / 32

Maximum working pressure	345 bar
Oil viscosity	ISO VG 46
Oil Quality, standards to be met	DIN 51524 part 3 , HVLP 46
Recommended oil	Statoil Hydraway HVXA 46
Examples of alternative oils with comparable properties	Castrol Hyspin AWH-M 46, Shell Tellus S2 V 46

	HT-W8/10	HT-W12/14
Pressure [bar]	Force [kN]	Force [kN]
25	3.2	6
50	6.4	12.3
75	9.6	18.5
100	12.7	24.6
125	15.9	31
150	19.1	37
175	22.3	43
200	25.5	48
225	28.7	55
250	31.9	60
275	35	68
300	38.3	74
325	41.4	80
345	44.0	85

HT-W8/10					
End type	Anodize colour	Thread UNF	Ø Pin [mm]	Part no.	Length min-max [mm]
Stud	Nature Black	5/8"-LH	16	580-003-10 580-004-10	L1=826-1246
R-screw body	Nature Black	5/8"-RH	16	580-003-11 580-004-11	L2=836-1404
Fork	Nature Black	-	16/16	580-003-21 580-004-21	L3=856-1276

HT-W12/14					
End type	Anodize colour	Thread UNF	Ø Pin [mm]	Part no.	Length min-max [mm]
Stud	Nature Black	7/8"-LH	22	580-007-10 580-008-10	L1=912-1392
R-screw body	Nature Black	7/8"-RH	22	580-007-11 580-008-11	L2=936-1566
Fork	Nature Black	-	22/22	580-007-21 580-008-21	L3=957-1437

Related Components / Spare Parts

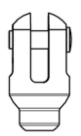
		HT-W8/10, SWL=44kN	HT-W12/14, SWL=85kN
RIGGING SCREW BODY		174-326-99	174-328-99
FORK		581-400-01 (Nature) 581-401-01 (Black)	581-402-01 (Nature) 581-403-01 (Black)

Fitting Instructions / Installation



The hydraulic system should be professionally installed.

Use only hydraulic hoses and connectors suitable for marine environment and working pressure 345 bar.

Be careful not to get any impurities into the hydraulic system.

Connection of hydraulic line:
1/8" BSPP thread with flat surface for seal washer

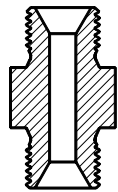
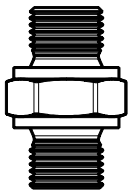
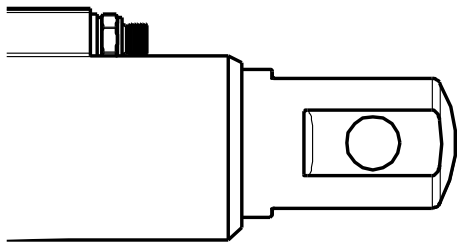

Connector for hydraulic pressure line 1/8" BSPP
Male with 60° Cone

For information about Seldén hoses, pump station and tank suitable for this product, please see Seldén manual 597-145-E "HYDR.PUMP STATION (HAND OP.)".

For advice regarding split pins please see Seldén 595-540-E "Hints and advice" p.18.

In order to get the rod to its extended position during installation a halyard can be connected to the rod end. After opening the pressure release valve on the pump station the rod can be extended.

Maintenance

Cleaning

We recommend rinsing the unit with freshwater at regular intervals. If detergents are used for cleaning it is important to rinse all traces off with fresh water afterwards. Most detergents contain elements that can corrode aluminium. Silicone free wax can be used to protect the surfaces.

Periodic Servicing

We recommend that you have the unit serviced at intervals of no more than five years in normal use. For boats used in charter operations or circumnavigation etc. the unit should be serviced on a more frequent basis.

It is very important that the hydraulic hoses are inspected as a part of the maintenance. They are to be replaced if they show signs of wear.

Storage

When stored please see to it that no stainless parts such as for example wire halyards or standing rigging is in contact with the aluminium surfaces, otherwise galvanic corrosion may occur.

See to it that during storage, the tensioner is kept dry and with access to air circulating around it. Do not wrap it in plastic or other impervious material.

Troubleshooting

- Problem:** Rod movement is uneven.
- Information:** Air is compressible and works like a spring when it is compressed.
- Probable cause:** Air in the hydraulic system.
- Action:** Check the hydraulic system for trapped air.



Hydraulic pressure can be dangerous.
This should be done by trained personnel.

- Problem:** Tension decreases quickly in the backstay
- Information:** The design of the tensioner is based on a piston on one end of the rod that gets oil pressure on one side, generating a pulling force in the rod. If pressure decreases quickly there is probably a leakage of oil from the pressurized side of the piston, past the piston seals.
- Action:** Check for external leakage such as past the rod seals.
Try operating the tensioner in its end positions to see if operation is OK apart from the loss of pressure.
The cylinder needs to be serviced, please contact a Selden representative.
- Problem:** Tension in stay not increasing when pumping at pump station
- Info:** Check that the pump station generates pressure as it should.
- If pressure is correct but the cylinder does not seem to function properly, try disconnecting the cylinder from the backstay and check if it contracts to its minimum length when supplied with pressurized oil.
- If the cylinder stops at a position not quite retracted to its minimum length, oil may have leaked past the piston seal to the lower side of the piston, causing the cylinder to stop before it reaches its contracted position.
- Action:** The cylinder needs to be serviced, please contact a Seldén representative.

DINGHIESKEELBOATSYACHTS

Seldén Mast AB, Sweden
Tel +46 (0)31 69 69 00
Fax +46 (0)31 29 71 37
e-mail info@seldenmast.com

Seldén Mast Limited, UK
Tel +44 (0) 1329 504000
Fax +44 (0) 1329 504049
e-mail info@seldenmast.co.uk

Seldén Mast Inc., USA
Tel +1 843-760-6278
Fax +1 843-760-1220
e-mail info@seldenus.com

Seldén Mast A/S, DK
Tel +45 39 18 44 00
Fax +45 39 27 17 00
e-mail info@seldenmast.dk

Seldén Mid Europe B.V., NL
Tel +31 (0) 111-698 120
Fax +31 (0) 111-698 130
e-mail info@seldenmast.nl

Seldén Mast SAS, FR
Tel +33 (0) 251 362 110
Fax +33 (0) 251 362 185
e-mail info@seldenmast.fr

Seldén Mast Asia Ltd, Hong Kong
Tel +852 3572 0613
Fax +852 3572 0623
e-mail info@seldenmast.com.hk

www.seldenmast.com

Dealer:

The Seldén Group is the world's leading manufacturer of mast and rigging systems in carbon and aluminium for dinghies, keelboats and yachts.

Our well known brands are Seldén and Furlex. The worldwide success of Furlex has enabled us to build a network of over 750 authorised dealers covering the world's marine markets. So wherever you sail, you can be sure of fast access to our service, spare parts and know-how.

SELDÉN and FURLEX are registered trademarks of Seldén Mast AB.

 **SELDÉN**