

Single line reef conversion kit - up to 2007

Instruction for modifying standard slab reefing booms

The maximum available height for SLR Reef 2 is limited by car movement inside the boom. It must not exceed the value in the table below. The reefing height for reef 1 should not exceed 60% of the value for reef 2.

Table 1

Boom profile	Max reefing height Reef 2	A (mm)	Reefing traveller
B135	E-650	200	511-636-01 (1 Slide) for 25 mm track 511-636-02 (2 Slides kit) for 25 mm track
B152	E-750	200	511-636-01 (1 Slide) for 25 mm track 511-636-02 (2 Slides kit) for 25 mm track
B171	E-850	250	511-636-01 (1 Slide) for 25 mm track 511-636-02 (2 Slides kit) for 25 mm track
B200	E-950	350	511-637-01 (1 Slide) for 32 mm track 511-637-02 (2 Slides kit) for 32 mm track
B250	E-1100	400	511-637-01 (1 Slide) for 32 mm track 511-637-02 (2 Slides kit) for 32 mm track

Tools required:

- * Pilot lines
- * Knife
- * Fabric Tape
- * Screwdriver (Phillips or Torx to loosen the boom end-fitting)
- * Adjustable wrench or shackle opener
- * Felt pen (for marking reefing lines)
- * Wire or equivalent. $L = \text{Boom length} + 0.5 \text{ m}$ (for threading pilot line)
- * Trestles, clamp

What the kit contents:

- 2 ea Blue- and red flecked lines.
Length ~ E-measurement
- 2 ea Blue- and red flecked lines.
Lengths; Blue ~ 4 x E-measurement ,
Red ~ 6 x E-measurement
- 2 ea Shackles
- 2 ea SLR blocks
- 2 ea Single blocks
- 2 ea Sheaves with pin and circular clips

Preparation:

1. Place the boom on two trestles with the sail groove uppermost. Hold it with a clamp to prevent movement.
2. Remove the outboard end-fitting. (Phillips or Torx screws).
3. Pull out the reefing lines from the end-fitting, and fix their ends to the outside of the boom tube with tape so they do not disappear inside the boom.
4. Feed the wire through the starboard outer sheave slot on the upper side of the boom inboard end fitting, and through the whole length of the boom. Check that it is not twisted around any reefing lines.
5. Tie a pilot line to the end of the wire and secure it with a piece of tape. Pull it through the boom. Secure the pilot line with tape at both ends of the boom.
6. Repeat point 4 and 5 on port side of the boom.
7. Fit the shaft with its two sheaves in the forward upper space in the boom inboard end fitting (see fig. 1). Secure the shaft with the circular clips in each end. Ensure that the pilot lines run correctly round their respective sheaves.
8. Fit the loose single blocks ④ to the holes in the flanges of the boom outboard end fitting. The shackle threads must shall face out towards the boom section wall.

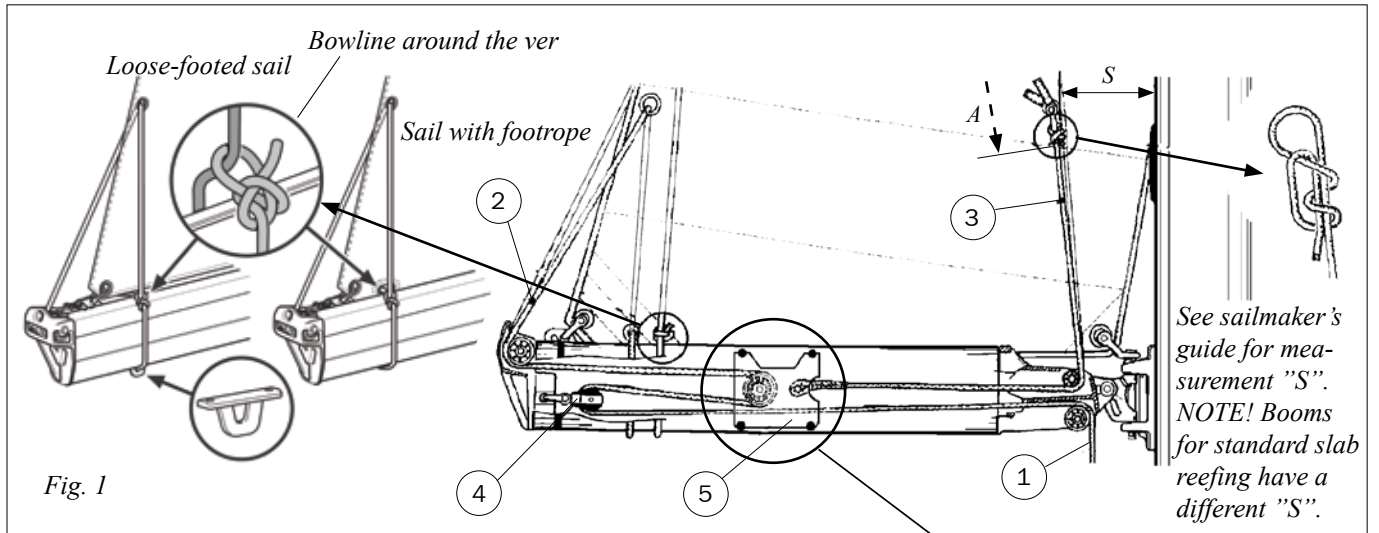

Fig. 1

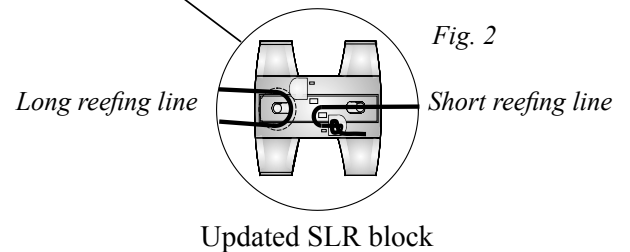

Fig. 2

Updated SLR block

Fitting the reefing lines:

Reef #1 (Blue flecked lines) use the starboard outer boom slots
 Reef #2 (Red flecked lines) use the port outer boom slots

- The old reefing lines are too short for SLR, so must be replaced. Join the new long reefing lines to the old reefing lines (Reef 1 and 2) where they exit the boom inboard end. The join is easily made by using as short length of messenger line, tied to each end with half hitches and secured with fabric tape.
- Pull through the new lines and attach them the same way as the old ones at booms outer end.
- The SLR blocks are symmetric and fit in either side of the boom from the outboard end. Select one SLR block, check that the arrow on the outer face is facing upwards and on the Starboard side, and then feed the new shorter blue flecked line (reef 1) in from the front and through the central hole. Turn the line forwards inside the block and secure with an overhand knot (see fig. 2). The knot should lay into the D-shaped recess in the block, and it's short tail tucked into the cavity immediately ahead.
- Knot or tape the starboard pilot line outer end to the free end of the knotted reefing line.
- Pull the pilot line at the boom end-fitting until the reefing line comes out round the sheave. Remove pilot line and make a stopper knot on the reefing line.
- Repeat actions 3, 4 and 5 on the port side with the short red flecked line (reef 2).
- Take the aft end of the starboard long reefing line ② that is taped to the boom section, and feed it up through the block ④, forwards and up through the SLR block ⑤, then aft out through the starboard boom end sheave slot (see fig. 1). Make a stopper knot in the end.
- Push the SLR block into the boom, at the same time pull the shorter reefing line ③ at the forward end. Check the long line ② that runs between boom end fittings is not trapped between SLR car and the boom side wall.
- Repeat action 7 and 8 with the port side long reefing line ②.
- Refit the boom end-fitting. Grease the screws with vaseline or similar to prevent corrosion.

Adjustment of Reefing Lines:

- Secure the reefing line ① either in the cockpit or where it exists the boom inboard end fitting.
- Pull the reefing line ② until then the SLR block ⑤ is stopped internally by the outer boom end-fitting. Secure the line temporarily.
- Tighten the reefing line ③. Where it exits the upper surface of the boom inboard end fitting, make a felt pen mark.
- Free the reefing line ①. Pull out about 1 m of reefing line ③.
- Make a second mark on the reefing line ③ A mm nearer the SLR block than the first mark. The dimension "A" for each boom type is listed in table 1.
- Tie on the shackle at the second mark with the knot that is showed in fig. 1. Pull the knot hard. The second mark A should be visible just below the knot.

Finish fitting on boat:

1. Connect the shackle on the reefing lines ③ to respective sides the sail.
2. Slacken the reefing lines ②, feed through the respective reef cringles, and secure around the boom (See fig. 1). If the sail has a footrope running in the boom's sail groove, it must have cringles or slits to allow the reefing lines ② to be feed through before being secured around the boom. The holes must be positioned correctly to ensure effective reefing. If the sail is loose-footed, the reefing lines are free to move. They can be held in the correct position a slide in the boom's underside track. (For suitable Seldén slide, see table 1).
3. Hoist the sail and check that there is some slack in the front reefing lines ③.
4. Test each reef in turn. When fully tensioned, mark the main halyard with sewn whippings for each reef at a reference point (for example outside the rope clutch). When reefing, the halyard can be released and then locked in the correct position before the reeflines are tensioned.
5. After any necessary adjustment have been made, cut off any surplus reef line. Melt or whip the line ends.
6. Cut surplus line on the reefing line ③ under the shackle. Leave a 30 mm tail outside the knot.
7. As with any type of slab reefing, the boom should be supported by a topping lift or a fixed rod kicker to prevent it from dropping into the cockpit when reefing.



The space between the boom sides and internal running blocks is limited. Check that new fittings, pop rivets or screws do no obstruct the movement of the blocks.

DINGHIES KEELBOATS YACHTS

Seldén Mast AB, Sweden
Tel +46 (0)31 69 69 00
Fax +46 (0)31 29 71 37
e-mail info@seldenmast.com

Seldén Mast Limited, UK
Tel +44 (0) 1329 504000
Fax +44 (0) 1329 504049
e-mail info@seldenmast.co.uk

Seldén Mast Inc., USA
Tel +1 843-760-6278
Fax +1 843-760-1220
e-mail info@seldenus.com

Seldén Mast A/S, DK
Tel +45 39 18 44 00
Fax +45 39 27 17 00
e-mail info@seldenmast.dk

Seldén Mid Europe B.V., NL
Tel +31 (0) 111-698 120
Fax +31 (0) 111-698 130
e-mail info@seldenmast.nl

Seldén Mast SAS, FR
Tel +33 (0) 251 362 110
Fax +33 (0) 251 362 185
e-mail info@seldenmast.fr

www.seldenmast.com

Dealer:

The Seldén Group is the world's leading manufacturer of masts and rigging systems in carbon and aluminium for dinghies, keelboats and yachts. The Group consists of Seldén Mast AB in Sweden, Seldén Mast A/S in Denmark, Seldén Mast Ltd in the UK, Seldén Mid Europe B.V. in the Netherlands, Seldén Mast SAS in France and Seldén Mast Inc in the USA. Our well known brands are Seldén and Furlex. The worldwide success of Furlex has enabled us to build a network of over 750 authorised dealers covering the world's marine markets. So wherever you sail, you can be sure of fast access to our service, spare parts and know-how.

