

# FURLEX 200S-500S

**FURLEX**

Jib furling and reefing system for yachts from approx. 30-70 ft



*Furlex 200S - 300S*

*Furlex 400S - 500S*

- Centred and insulated forestay and completely insulated joining sleeves make furling easier, reduce wear and cut out the risk of corrosion.
- Unique, patented load-distributor for easy furling and unrivalled bearing durability. Lightweight halyard swivel keeps weight aloft to a minimum.
- Sailfeeder in high grade, marine stainless steel for improved durability and service life. Composite connector for the optimum strength-to-weight ratio.
- Tack swivel with a free-turn, combined with the uniform profile of the forestay extrusion, give a perfectly furled sail and effective performance even when reefed. Twin grooves and split drum – allow for fast sail changes and make Furlex easily adapted for racing.
- Unique line-guide system – controls and centres furling line and arranges it evenly onto the drum.
- Fully integral rigging screw (optional) for fast and simple forestay adjustment, without affecting the uniform profile of the extrusion or the drum height above deck. The rigging screw adjusts through 60 mm, 80 and 100 mm depending on size of system.

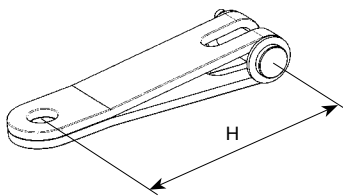

Extension link: Used to increase the distance between the lower unit and the deck for a bow anchor etc.

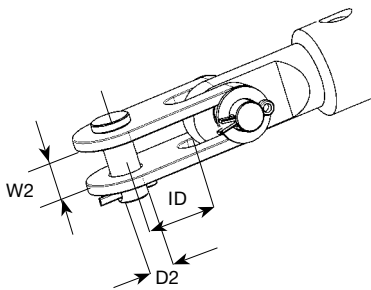

Furlex standard toggle.

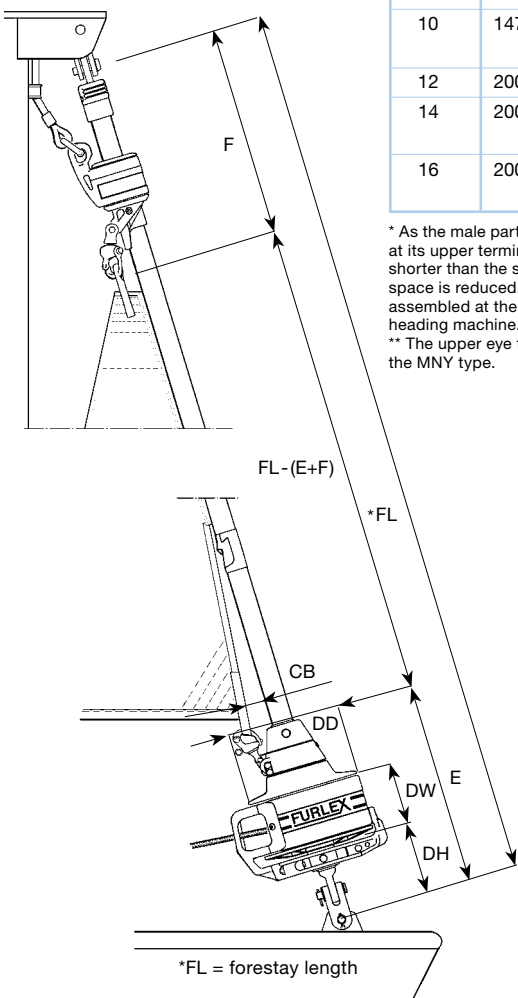

Complete system.

Furlex is available with Dyform wire. Information on Furlex Hydraulic is available separately. Please ask for details.

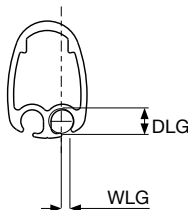

Furlex series	Forestay dia. mm	Rod dia. (mm)	Navtec	OYS** (Riggarna)	BSI	Max righting moment (kNm) at 30° heel		Approx. displacement, tonnes	
						Masthead rig	Fractional rig	Masthead rig	Fractional rig
200S	6	-8 (5.7)	X	X	X	19	23	3.9	4.5
	7	-10 (6.4)	X	X	X	27	34	5.5	7
	8	-12 (7.1)	X		X	37	45	7.5	9
300S	8	-12 (7.1)	X		X	40	50	8	10
		-15 (7.5)		X*	X				
	10	-17 (8.4)	X		X	70	80	14	15
400S	12	-30 (11.1)	X	X	X	120	160	20	26
	14	-30 (11.1)	X		X	180	190	28	30
		-40 (12.7)	X	X	X				
500S	16	-40 (12.7)	X	X	X	230	250	38	40
		-48 (14.3)	X	X	X				

Forestay dia. (mm)	DH mm	DW mm	DD mm	CB mm	E mm	F mm	ID mm	W2 mm	D2 Clevis pin	Forestay adjustment dia., mm	Extension link H mm	Halyard sheave box Art. No.
6	120	94	186	60	330	540	24	11	10	60	90	505-006-10
7	120	94	186	60	330	540	24	12.5	12	60	90	505-006-10
8	120	94	186	60	330	540	31	15.5	14	60	130	505-012-10
8	147	113	216	80	400	550	31	15.5	14	80	130	505-012-10
10	147	113	216	80	400	550	34	16	16	80	130	505-012-10
12	200	140	250	95	535	620	40	21	19	100	190	505-012-10
14	200	140	250	95	535	620	50	23	22	100	190	505-012-10
16	200	140	250	95	535	620	50	26	22	100	-	505-038-01

\* As the male part of this rod terminal type/size is too large to pass through the luff extrusions, the rod forestay can only be cold-headed at its upper terminal end after the stay has been pulled through the assembled extrusions. The extrusion must be made 200 mm (8") shorter than the stay at the top to make room for the cold-heading machine. Consequently, the luff extrusions length and available sail space is reduced. The system has to be assembled at the location of the cold-heading machine.

\*\* The upper eye terminal must be of the MNY type.

Furlex series	Forestay dia. mm	Max. forestay length, m	Art. No. Standard version	Art. No. Incl. rigging screw
200S	6	10.6	031-021-51	031-021-61
	6	13.0	031-021-52	031-021-62
	6	15.4	031-021-53	031-021-63
	7	13.0	031-021-54	031-021-64
	7	15.4	031-021-55	031-021-65
	7	17.8	031-021-56	031-021-66
	8	15.4	031-021-57	031-021-67
	8	17.8	031-021-58	031-021-68
300S	8	15.5	039-027-51	039-027-61
	8	17.9	039-027-52	039-027-62
	10	15.5	039-027-53	039-027-63
	10	17.9	039-027-54	039-027-64
	10	20.3	039-027-55	039-027-65
400S	12	17.7	049-034-51	049-034-61
	12	20.1	049-034-52	049-034-62
	12	22.5	049-034-53	049-034-63
	14	20.1	049-034-54	049-034-64
	14	22.5	049-034-55	049-034-65
500S	16	23.0	060-046-56	060-046-66
	16	27.8	060-046-57	060-046-67

Furlex series	Internal diameter of luff groove (DLG), ø mm	Width of luff groove (WLG), mm
200S	6.0	3.0
300S	7.5	3.0
400S	8.0	3.0
500S	9.2	3.0

**SELDÉN and FURLEX are registered trademarks of Seldén Mast AB**  
 Seldén Mast AB, Sweden Tel +46 (0)31 69 69 00. Fax +46 (0)31 29 71 37. e-mail info@seldenmast.com  
 Seldén Mast Limited, UK Tel +44 (0)1329 50 40 00. Fax +44 (0)1329 50 40 49. e-mail info@seldenmast.co.uk  
 Seldén Mast Inc., USA Tel +1 843-760-6278. Fax +1 843-760-1220. e-mail info@seldenmast.com  
 Seldén Mast A/S, Denmark Tel +45 39 18 44 00. Fax +45 39 27 17 00. e-mail info@seldenmast.dk  
 Seldén Mid Europe B.V., Netherlands Tel +31 (0) 111-698 120. Fax +31 (0) 111-698 130. e-mail info@seldenmast.nl  
 Seldén Mast SAS, France Tel +33 (0) 251 362 110. Fax +33 (0) 251 362 185. e-mail info@seldenmast.fr  
 www.seldenmast.com

 **SELDÉN**  
for sailing