

Assembly instruction



Tools Required:

Saw
Drill
Ø 6.5 mm drill bit
Screwdriver torx
Hammer
Pop Rivet Gun

Parts included in kit

Extrusion with outboard end fitted
Inboard end
Fasteners
Pad eyes (screw M6 not incl.)

Assembly

1. Find the correct length, see table 2 (DBS + USL). When in doubt, contact dealer.
2. Mark the length of the extrusion, see table 1 for reductions. (Use a paper as a guide as fig. 1). Cut the extrusion.
3. Mark the holes for the rivets, according to table 1.
4. Drill the holes with a Ø 6.5 mm drill bit.
5. Fit the inboard end with pop-rivets and punch out the mandrel heads.

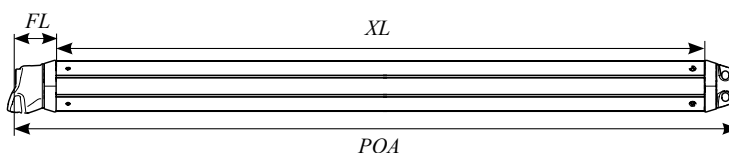
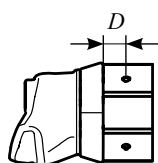
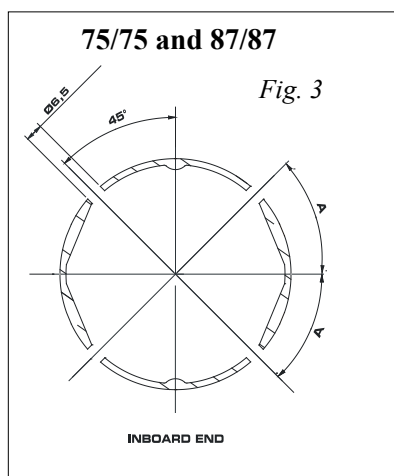
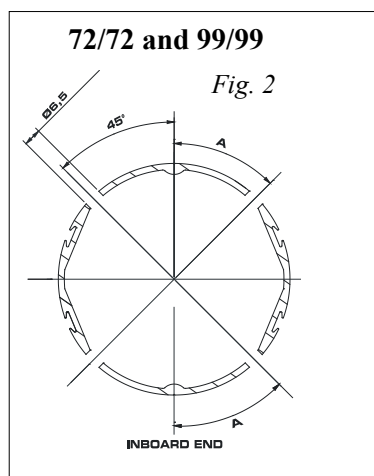
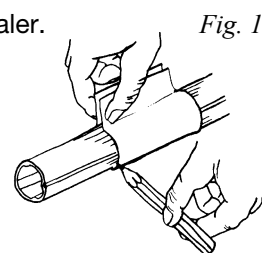

Bowsprit size	A	D	Extrusion length
G072	29	40	XL = POA - 78
G075	30	40	XL = POA - 78
G087	34	20	XL = POA - 122
G099	39	20	XL = POA - 158
G120	47	25	XL = POA - 63

Tab. 1