

Manual for Furling mast TYPE RB/RC



 **SELDÉN**

Contents:	Page:	Contents:	Page:
Product description	2	Spare mainsail	9
Checks and adjustments before stepping	4	The sail	10
Operation & operational hints	6	Running cables	11
Fitting and hoisting the sail	8	Maintenance	12
Before sailing	9	Dismantling	14

Product description

- Seldén Mast in-mast furling mast is a mainsail reefing and furling system.
- The furling gear has been developed from experience gained from FURLEX foresail roller-reefing, and is dimensioned for the toughest conditions.
- The unique design of the halyard swivel bearing distributes the load over the whole ball-race to give smoother furling and the lowest possible friction.
- The entire reefing mechanism can be easily removed from the mast for service. Stainless steel thread inserts are used for all screws, so that dismantling is easy even after many years usage in a corrosive environment.
- The mast extrusion has an additional luff groove for a storm trysail or spare main. A foresail with rope luff could be hoisted.
- This Instruction Manual has been compiled to give you information on the in-mast reefing system. Study it and follow the instructions carefully, and we guarantee you many years of pleasurable use from your Seldén Mast in-mast furling mast.
- Follow the relevant rigging instructions in our booklet "HINTS AND ADVICE" for tuning the rig.

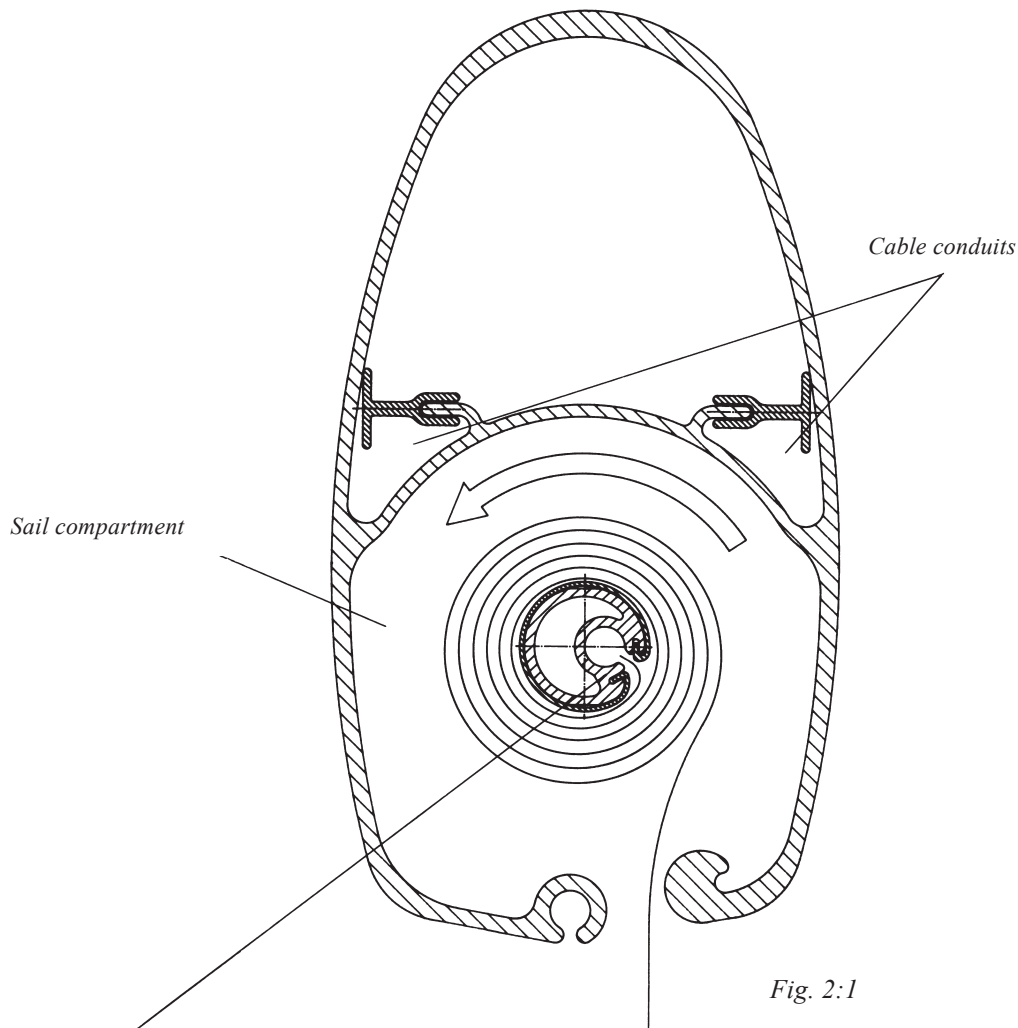

Fig. 2:1

Asymmetric luff extrusion giving reduced initial resistance to reefing due to easier bending of the luff.

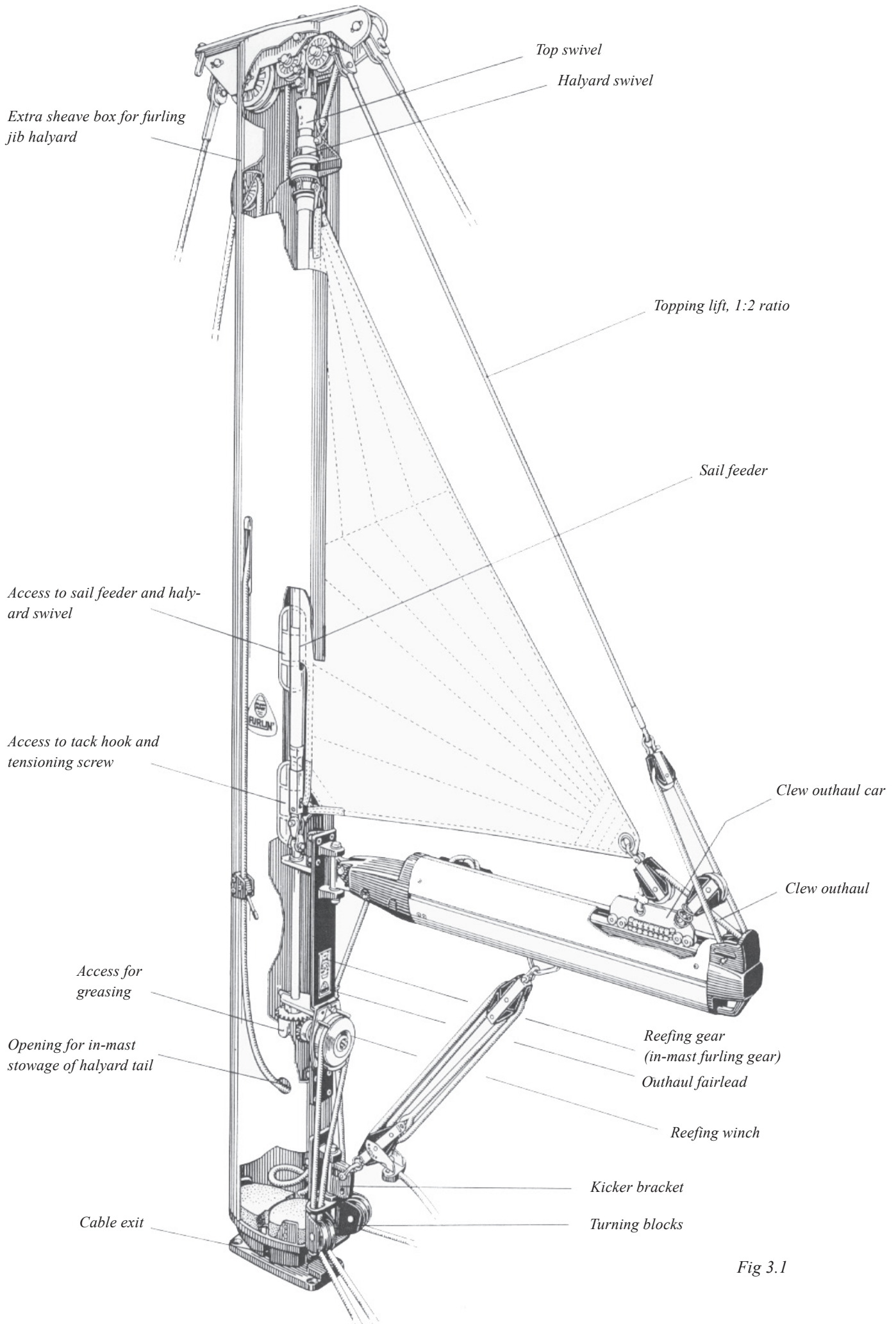

Fig 3.1

Checking luff extrusion tension prior to stepping the mast

The luff extrusion is correctly tensioned before leaving the factory, but tension can be re-checked before stepping the mast.

Lay the mast horizontally, and check that the extrusion is just clear of the mast wall at its mid point. If adjustment is necessary see points 1-5 below.

If adjustment has to be made after the mast has been stepped, then the luff extrusion should be so tensioned that it does not beat against the mast walling when you grasp it through the upper access hole and shake it.

Most of the extrusion will be resting on the aft face of the sail compartment when sailing.

DO NOT OVER-TENSION! A luff extrusion that is over-tensioned will increase furling friction.

Luff extrusion adjustment

1. Remove the access covers.

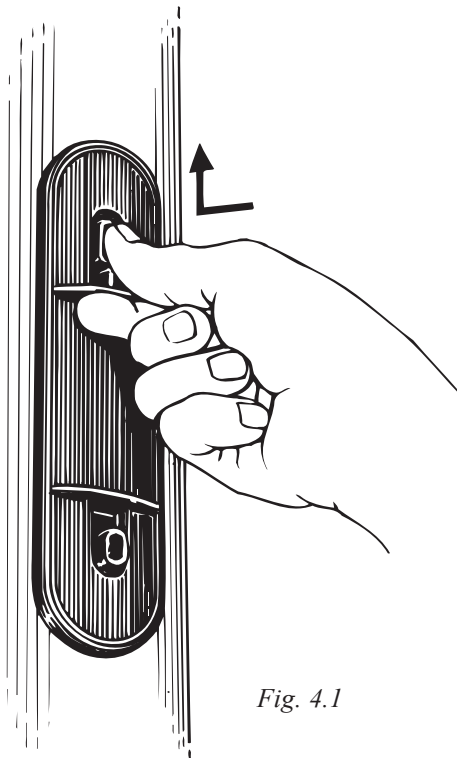

Fig. 4.1

Depress one button and push.

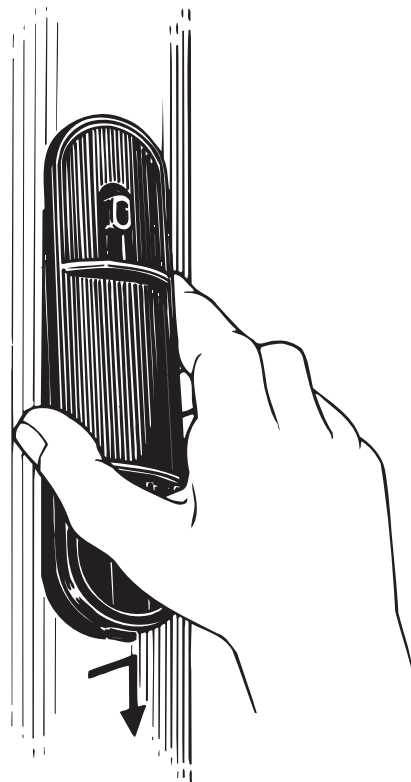
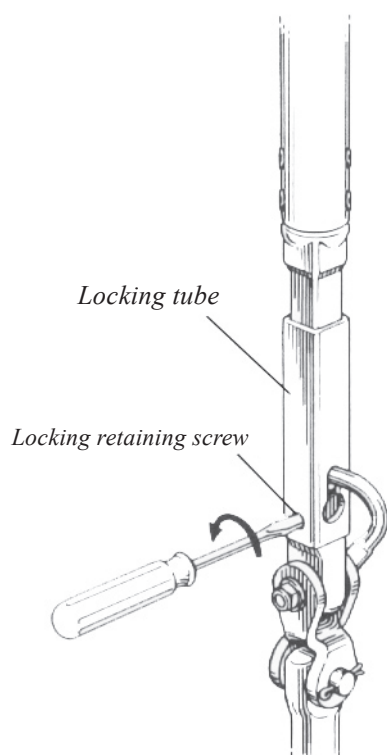

Fig. 4.2

Lift the opposite end and remove.

1.



Undo the lock retaining screw and free the locking tube.

2.

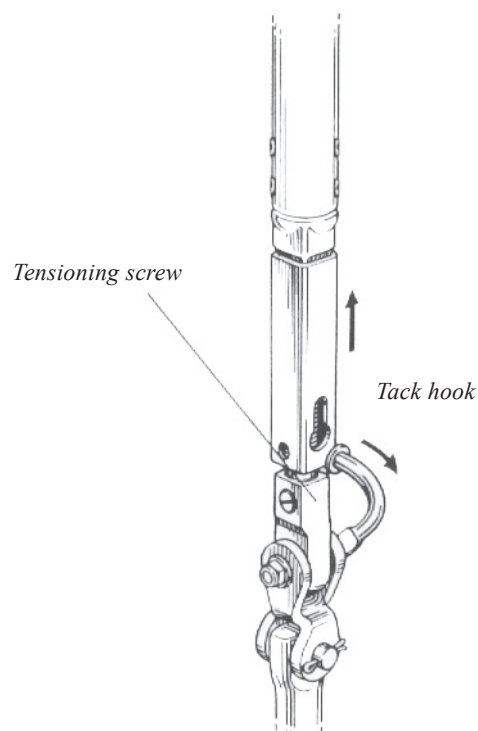

Push the locking tube upwards while at the same time turning the tack hook out of its key-hole slot. The tensioning screw is now freed.

Twist the tack hook back towards the tensioning screw so that it will not get snagged during step 4.

3.

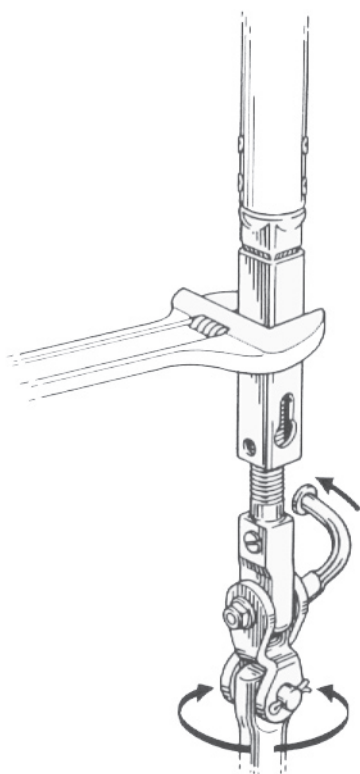

Using an adjustable wrench prevent the locking tube from turning while adjusting the luff extrusion tension by turning the reefing winch.

The final turn should ensure that the tack hook and its key-hole slot will mate up.

4.

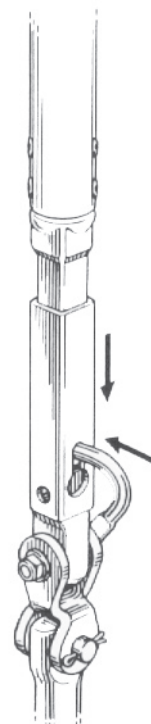

Lower the locking tube while at the same time engaging the tack hook into the key-hole slot. Replace the lock retaining screw.

Operation & Operational hints

Reefing and unreefing is accomplished with a reefing line and an outhaul, either through working at the mast, (see fig. 7.1). or by the lines for operation from the cockpit.

If in-mast furling mast is to be operated from the cockpit then a reefing line in the form of an endless loop in combination with a self-tailing winch is recommended. The loop should be sufficient long to permit easy removal from the winch. Slack on the unloaded side of the loop should be taken up and held with the aid of a cleat or a Clam-cleat. A rope stopper can also be used, but the reefing line will have to be spliced after being threaded through it.

A self-tailing winch is also recommended for the outhaul. Fig. 6.1 and 6.2 illustrate two possible arrangements.

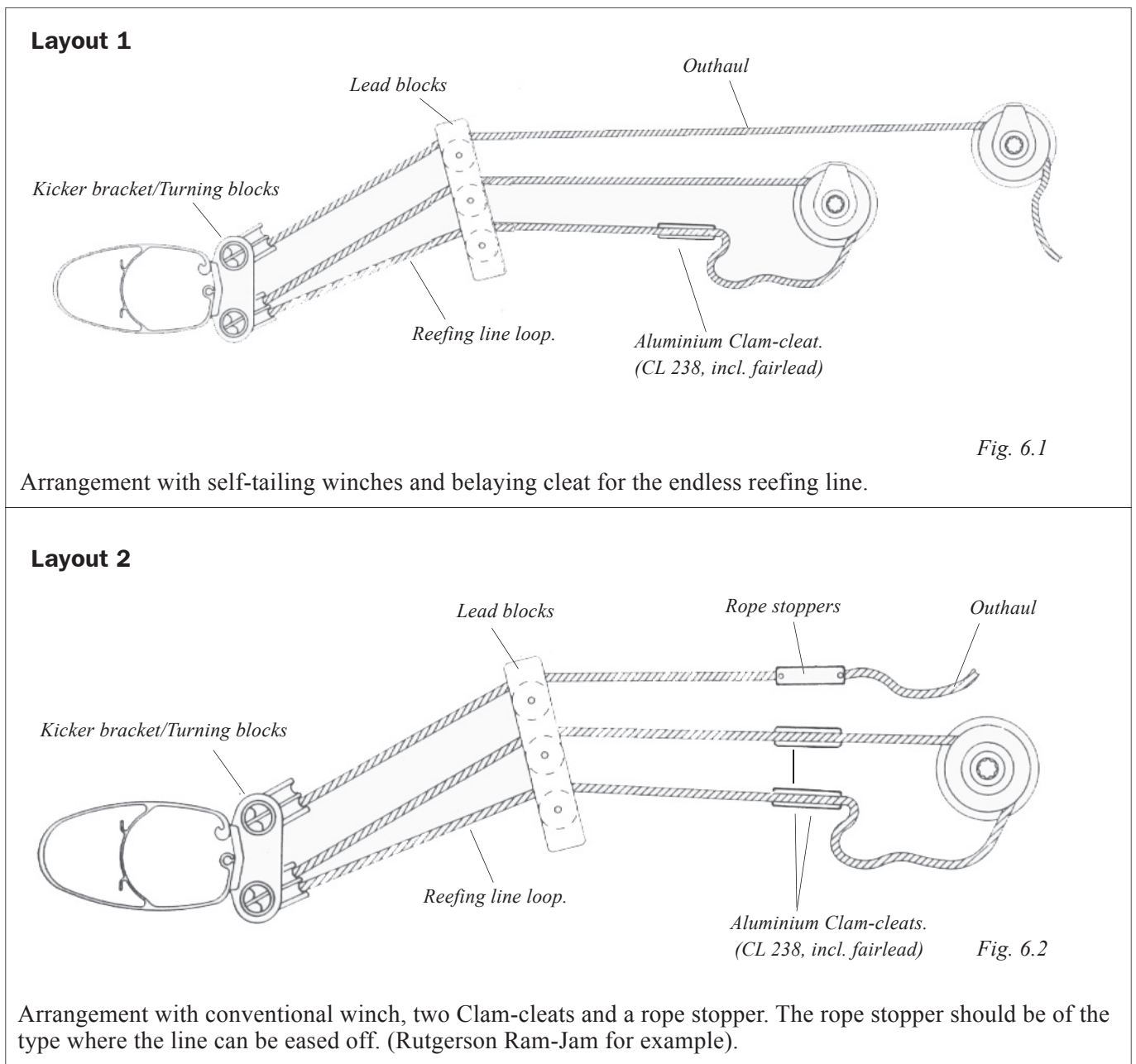

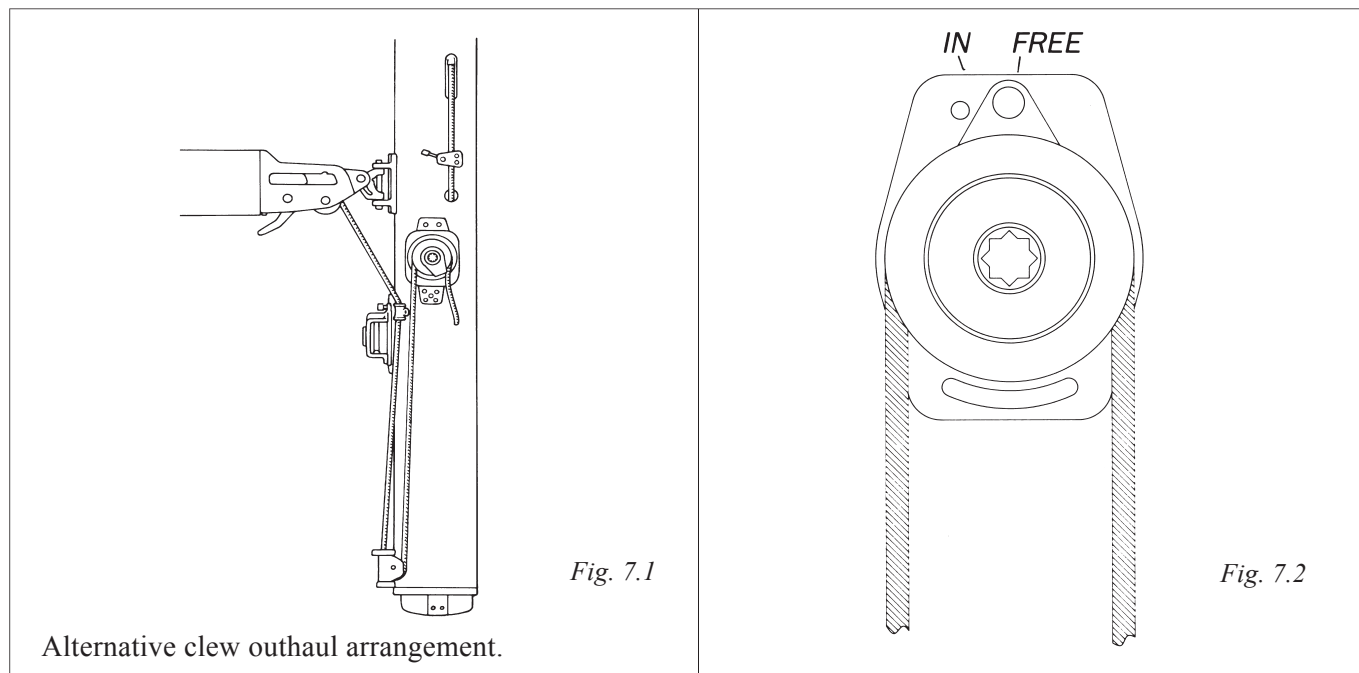

Alternative clew outhaul arrangement.

Fig. 7.1

Fig. 7.2

- When reefing from the cockpit the reefing winch must be set to "FREE".
- Use 10 mm diameter double plaited line for the endless loop.
- The mast kicking bracket/turning block on the mast has removable sheaves to allow a pre-spliced endless loop to be threaded.
Note. This turnings block are designed for use on the reefing system only.
- If deck lead blocks are used we recommend those with three removable sheaves from Seldén Mast. (Part No. 538-809-01. A pre-spliced endless loop can be threaded through them.
- If fittings from other suppliers are used they should have similar features. Fittings with permanent sheaves will entail splicing in situ, with the awkwardness that entails.

Operating hints

Unfurling

1. Free both sides of the endless loop from the winch and Clam-Cleat. It will then slide on the reefing winch.
2. Pull out the sail with the outhaul line.

Furling

1. The leech should be kept fairly tight when reefing or furling. Adjust the topping lift to achieve this, and the sail will form a good tight roll around the luff extrusion.
2. Whilst keeping slight tension on the outhaul line, pull in the sail using the winch for the endless reefing loop.

Reefing

1. Carefully slacken off the outhaul line.
2. Whilst continuing to ease off the outhaul, roll in the desired amount of sail.
3. When the desired amount of sail is rolled in, use the outhaul to stretch the foot of the sail.

When operating from the cockpit:

Make both "sides" of the reefing line fast to prevent slip on the reefing winch. Finally, tension the outhaul. The reefing winch should be locked ("IN") when sailing in heavy weather so as to avoid its rotating due to line slip. This will not prevent further reefing, but the lock must be released before unreefing.

When working at the mast:

Hold the sail to its reefed size by using the stop on the reefing winch ("IN").



**WARNING! Never leave the handle in the reefing winch!
It will rotate very rapidly when the sail is unfurled.**

Fitting and hoisting sail

1. Check that the tack and head of the sail are made as illustrated on page 10. An incorrectly made tack can cause wrinkles in the sail and make smooth furling difficult.

2. Remove the covers.

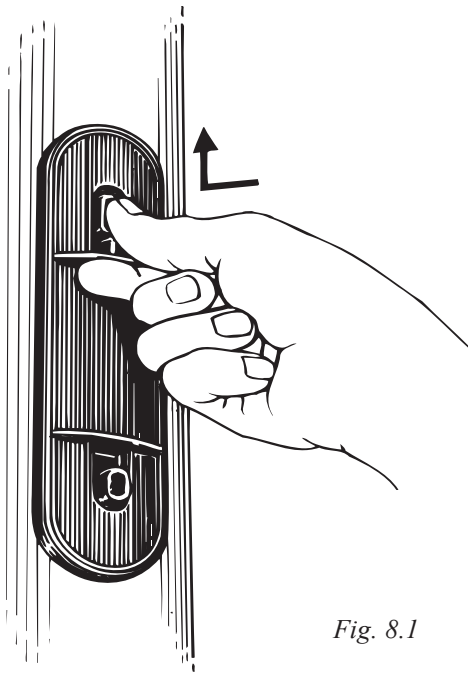

Fig. 8.1

Depress one button and push.

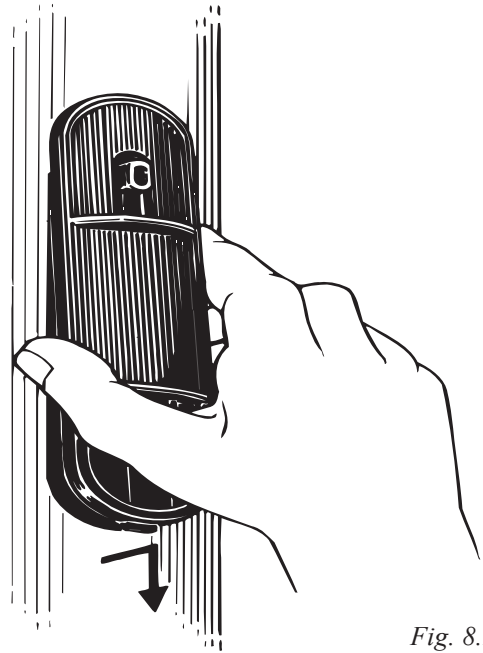
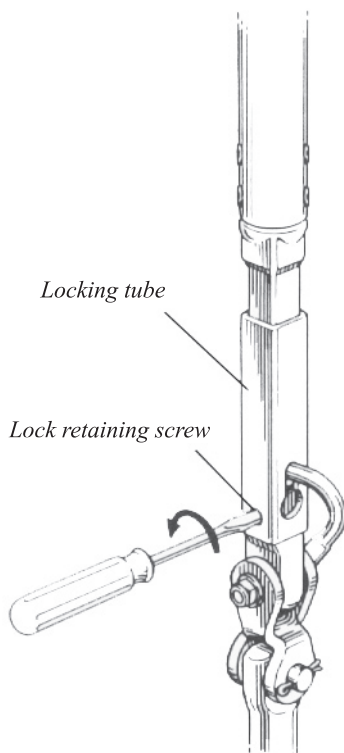

Fig. 8.2

Lift the opposite end and remove.

3. Join the head to the halyard swivel.

4. Join the tack to the tack hook.



Remove the lock retaining screw to free the locking tube.

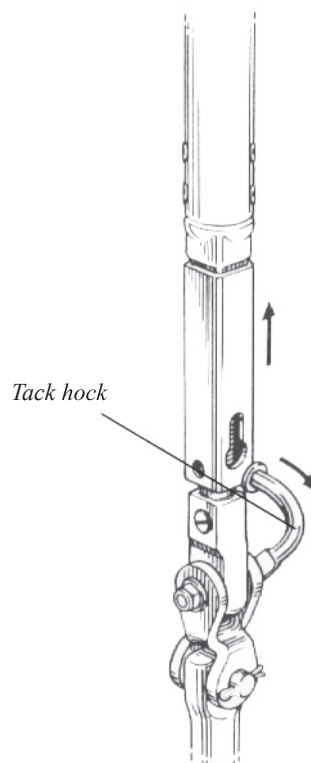

Twist the tack hook away from the keyhole slot while at the same time raising the locking tube. (The tensioning screw is now exposed). Hock on the sail tack.

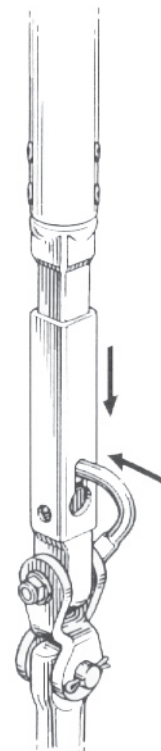

Lower the locking tube again while at the same time re-engaging the tack hook into the keyhole slot. Replace the lock retaining screw.

5. Hoist the mainsail whilst simultaneously ensuring that it is feeding correctly into the luff extrusion.
6. Set the halyard and cleat it with the rope stopper. The halyard tail can be stowed in the mast by feeding it through the hole just below the halyard winch.
7. Furl the sail until the clew is exposed. The luff extrusion is asymmetrical to facilitate rolling in one direction, and the sail should always be rolled onto the starboard side of the luff extrusion. The reefing winch should be turned clockwise. See fig. 9.1.
8. Attach the clew to the outhaul car.



Note. Turn the reefing winch clockwise for correct furling.

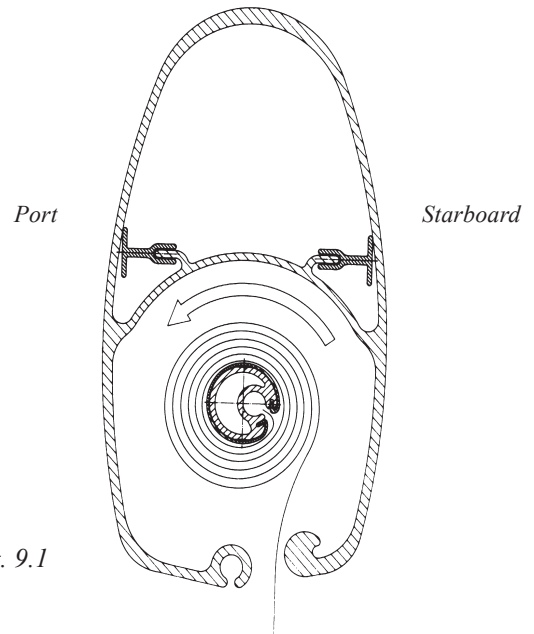

Fig. 9.1

Before sailing

1. Check that the sail is correctly furled on the luff extrusion: i.e. to its starboard side. (See fig. 9.1).
2. Whilst still on the mooring furl and unfurl the sail a couple of times to ensure that the system works as it should, and to familiarise yourself with its operation, and also to check that the sail is correct size.
3. Adjust the topping lift to achieve the desired sail shape. The topping lift determines sail twist; its effect being comparable to changing foresail sheeting angles.

Spare mainsail

The integral luff-groove on the after face of the mast can be used for hoisting a spare sail. A foresail made to fit the Furlex luff furl can be used. The luff groove dimensions are the same as those for the roller extrusion, as shown in fig. 10.1.

If the spare sail is fitted with slides, then Aquabatten No. A032 or Rutgerson 101 are recommended.

Anti-vibration strip

Vibration can occur in any aluminium mast of normal design. With wind coming from approximately abeam at speeds of 4–12 Knots the mast oscillates longitudinally at a rate of 3–6 cycles per second. Every Seldén Mast in-mast furling mast is supplied with an "anti-vibration strip" for hoisting in the integral sail groove to prevent vibration starting. It will also reduce wind noise.

The sail

The luff extrusion is asymmetrically shaped to help overcome initial resistance when starting to furl. Do not use too heavy sail cloth in the luff area.

To improve sail shape when reefed and to reduce draft. "Luff foam" may be used along the luff. The foam should not be placed closer than 50 mm (2") from the front edge of the luff as it will then increase initial reefing resistance.

Sail dimensions

- We recommend maximum 8 mm (5/16") diameter luff-rope/luff-tape (maximum 7 mm (9/32") hard line). Luff groove dimensions are shown in fig. 10.2.
- Head and tack tapes should be of soft quality which can fold easily. Do not use metal eyelets on them.
- The clew cringle must not be thicker than 14 mm (35/64") in order to fit the outhaul block.

Extrusion	A	B	T
R 214/122	600	400	130
R 232/126	600	400	130
R 260/136	600	400	130
R 290/150	700	500	140

Boom extrusion	OS
128/90	250
150/105	250
162/125	250
189/132	350
206/139	350

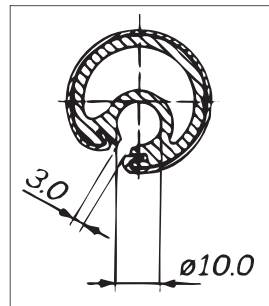
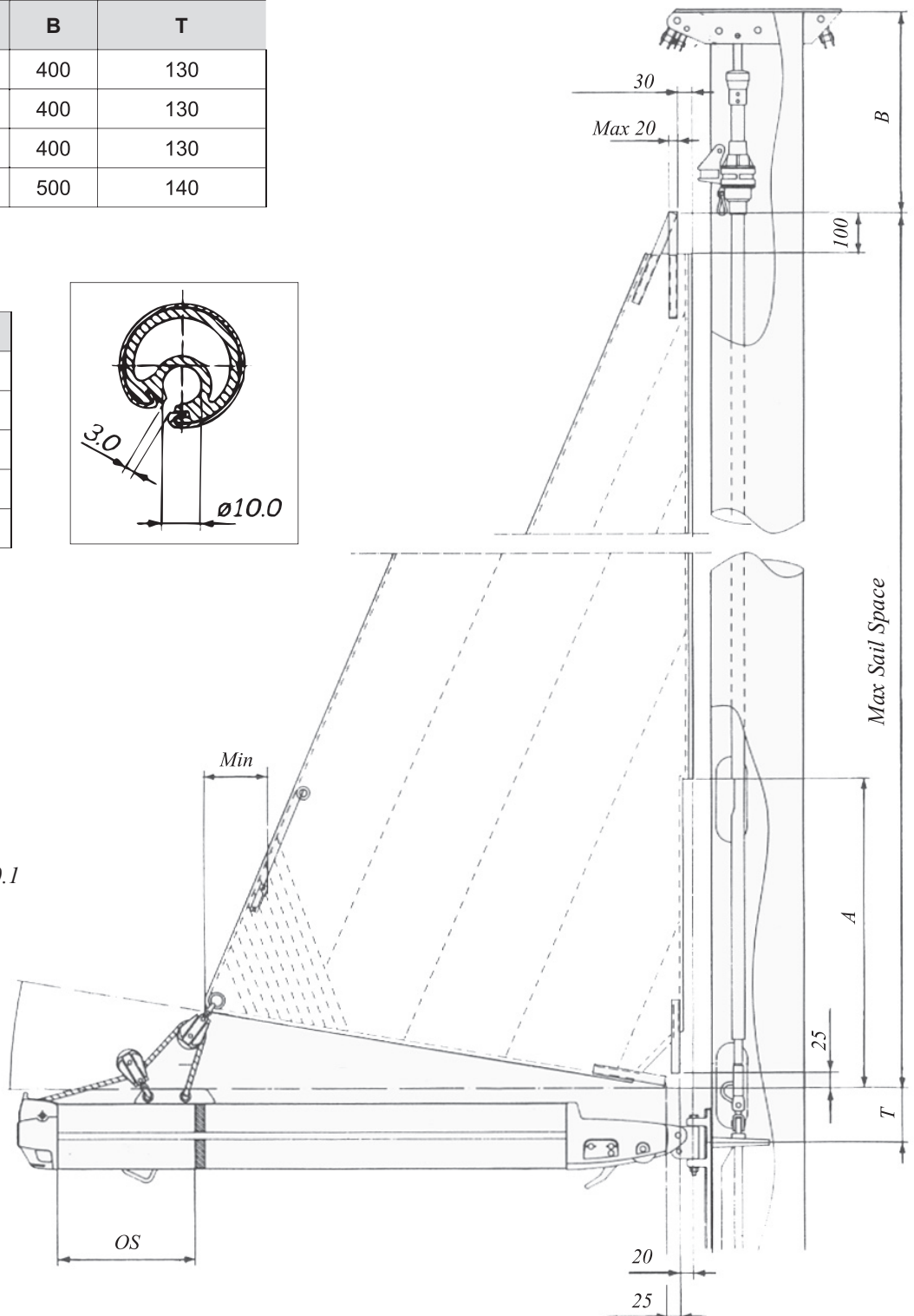

Fig. 10.1



Running cables

All in-mast furling mast extrusions have one or more cable conduits. These run uninterrupted to the mast heel even on keel stepped masts.

A messenger is threaded through all empty conduits at the factory to facilitate cable drawing.

A new messenger should be drawn through a conduit at the same time as a cable is drawn through. This will facilitate the running of additional cables.

If an existing cable should prevent a new one being run, it should be extracted after first having attached a new messenger to it to take its place in the conduit. That messenger can then be used to pull two or more cables through the conduit simultaneously.

Cables are led into a conduit at the masthead through a hole in the side of the mast extrusion. Cables should be over-length. The head box can then later be removed without the need to disconnect electric installations. Cable exits are located in the mast heel casting.

Extrusion:
214/122

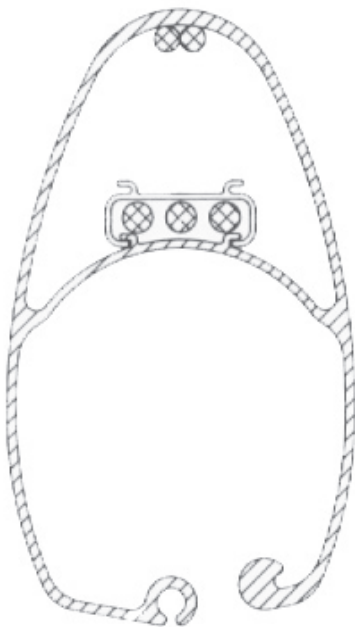

Fig. 11.1

When retro-fitting cables from the front of the mast run them through the halyard chamber as illustrated. Pull the cables tight to prevent them slapping the extrusion later.

Extrusion:
232/126
260/136
290/150

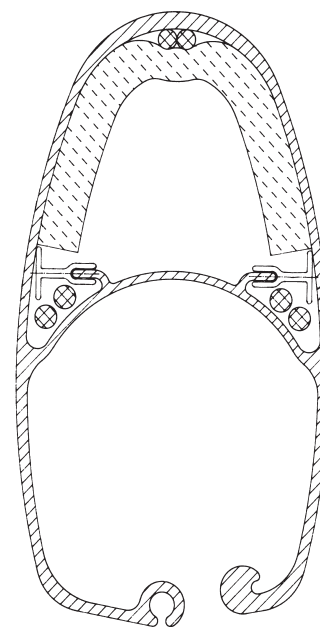

Fig. 11.2

Cables for forward-facing electrical installations are held in place with an "ETHAFOAM" pad to eliminate slapping.

If additional cables from mid mast installations are required, proceed as follows.

1. Lay the mast with forward face uppermost so that the cables will rest in one corner of the conduit.
2. Drill the exit hole for the cable through the other corner and forward of the cable. Use great caution when drilling so as not to damage the cable.
3. Carefully burr the hole to eliminate any sharp edges that could cause chafe. Some tape around the cable will give added protection.

Maintenance of the in-mast furling mast

Periodic Maintenance

Maintenance should be undertaken at least once a year. All bearings should be greased with GREASE (Part No. 312-501), a tube of which is delivered with the mast. Read the following instructions and fig. 13.1.

When greasing bearings and gears, do not over-grease. A thin coating of evenly applied grease is sufficient.

TOP SWIVEL:

The bearing has a lubrication hole ① marked "GREASE" where the grease should be injected. Access through the sail slot.

HALYARD SWIVEL:

Lubricate the swivel by injecting grease into the gaps ② & ③ in the ring. This is best done through the upper access hole.

IN-MAST FURLING MAST GEAR.

Lift the rubber boot and grease the upper shaft bearing ④.

Access is from the lower access hole.

The lower parts are accessible for greasing after the small oval plastic plug on a level with the reefing winch has been removed.

Grease the bevel gears ⑤ and ball-bearings ⑥ & ⑦.

All grease points are shown in fig. 13.1.

Complete Service

It is a good idea after some years use to dismantle the gear for thorough cleaning and re-greasing. The in-mast furling mast is built so that servicing will be easy even after protracted use. Stainless steel thread inserts for all screw fastenings ensure that corrosion is eliminated.

Dismantling procedures are described on page 14.

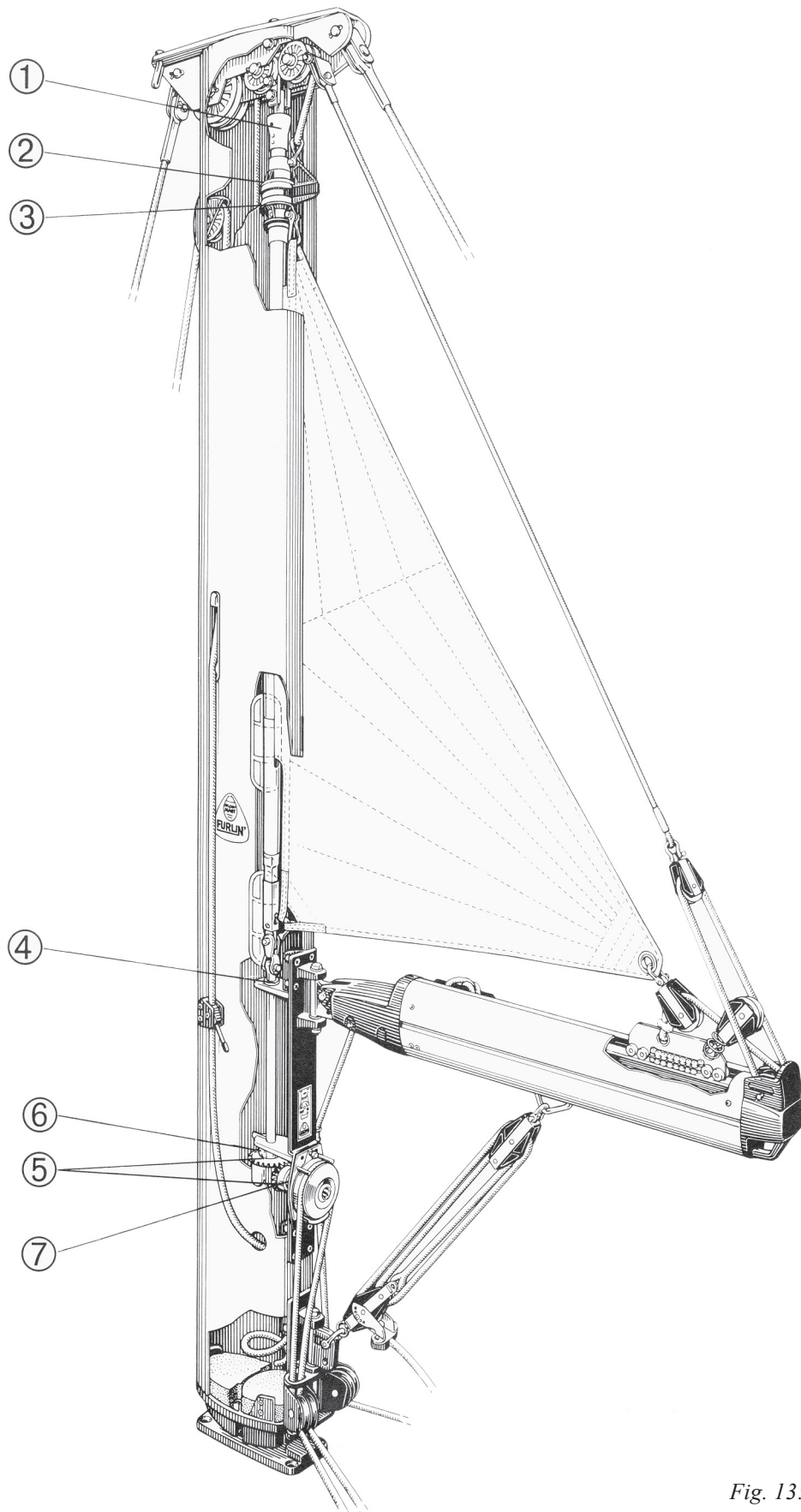
*Fig. 13:1*

Removal of the in-mast furling mast gear from the mast

1. Lay the mast horizontally on trestles.
2. Detach the luff extrusion from the in-mast furling mast gear by slackening the tension and undoing the toggle. (See page 4, "Luff extrusion adjustment").
3. Remove the in-mast furling mast gear from the mast by undoing the eight holding bolts and taking it away from the mast. (The in-mast furling mast gear can be removed even when the mast is stepped).
4. Remove the headbox by undoing the nuts on top and lifting it off.
5. Remove the top swivel from the luff extrusion.
Top swivel 540-104: Undo the two lower bolts. (The upper bolts holds the swivel halves together).
Top swivel 540-204: Undo the three lower bolts. (The upper bolts holds the swivel halves together).
6. Slide the halyard swivel off the luff extrusion.

Dismantling units with ball bearings

All dismantling should be undertaken on a clean unbroken surface. The various ball bearing units contain many small parts that fall apart when dismantling. Lay the dismantled parts out in an orderly manner.

Dismantling the in-mast furling mast gear

Tools required:

- Hammer
- Punch, (6–8 mm) (1/4–5/16").
- Allen key, 6 mm.
- Screwdriver, small

1. Drive the spring-pin ① from the large bevel gear. Use hammer and punch.
2. Draw the shaft ② up and out from the in-mast furling mast gear. Take care of the balls and races which will fall apart.
3. Drive out the spring-pin ③ from the small bevel gear. Draw the gear and ball bearings off the shaft.

Take care of ball bearings and races, which will fall apart.

4. Undo the four bolts holding the reefing winch, and remove the winch from the holding bracket. Remove loose components from the reverse side of the winch, and remove the locking ring from the shaft. The winch can then be dismantled.
5. Clean the ball bearings, their races, gears, and winch components in a white spirit bath.
6. Reassemble all components in the reverse order. The winch must be greased before reassembly. A layer of grease in the cupped half of a ball-race will hold the balls in place during assembly. Grease the bevel gear teeth.

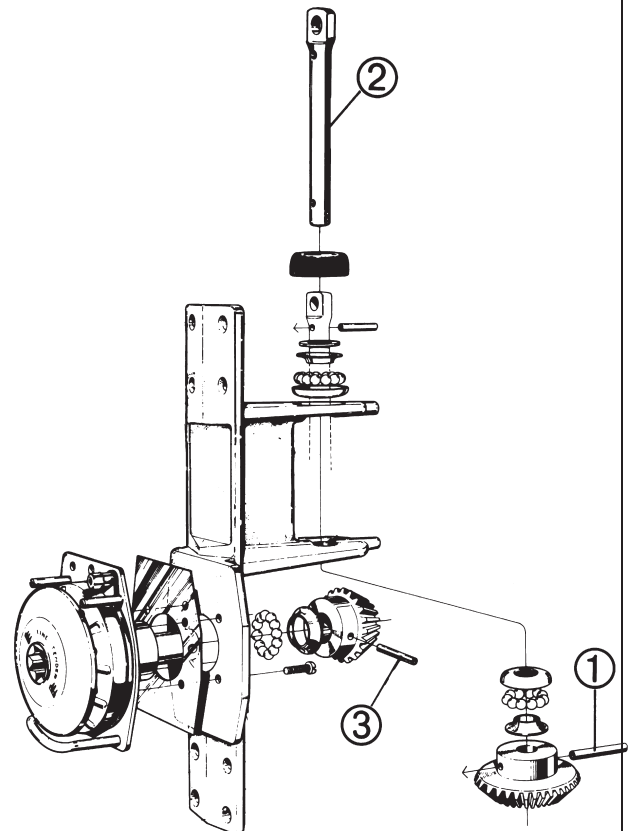

Fig 14.1

Dismantling the halyard Swivel:

Tools required:
– Phillips screw-driver

1. RB/540-107 Remove both screws ①.
1. RC/540-209 Remove both screws ① and the four screws in the stainless steel ring.
2. Turn item ② 90° to free the bayonet fitting, and remove it.
3. Lift ③ off together with one ball bearing. Then lift off the second ball bearing.



NOTE.
Ball bearings may fall apart. Take care not to loose any parts.

4. Clean ball bearings and their races in a white spirit bath.
5. Reassemble the components in the reverse order.
A layer of grease in the cupped half of a ball-race will hold the balls in place during assembly.

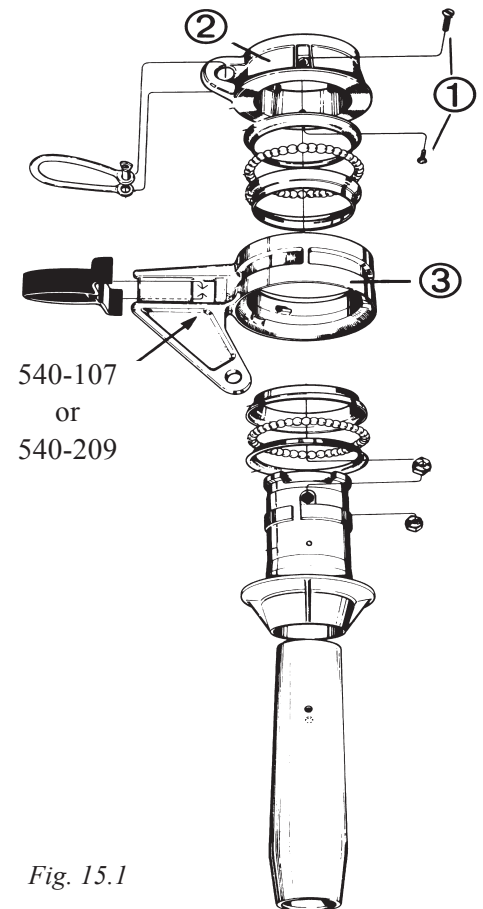

Dismantling the top Swivel:

Tools required:
– Screw-driver
– Adjustable wrench

1. Remove the remaining upper screw/screws holding the two halves of the casting together.
2. Dismantle the ball bearing and wash it in a white spirit bath.
3. Reassemble in the reverse order. A layer of grease in the cupped half of a ball-race will hold the balls in place during assembly.

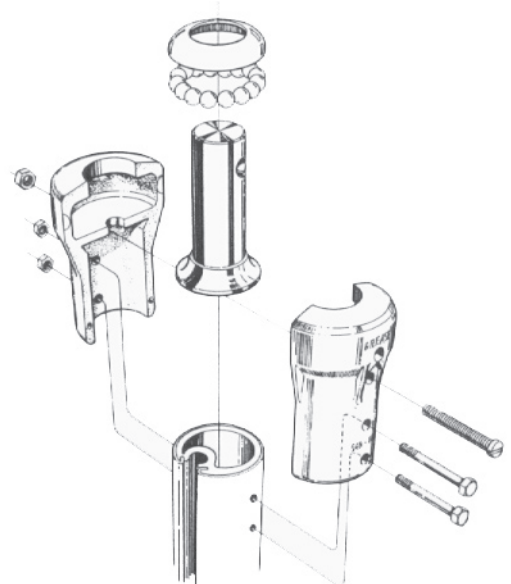

Important points to remember before setting sail

- The sail must always be rolled to the starboard side of the luff extrusion. Turn the reefing winch clockwise.
- The leech should always be kept fairly taught when reefing or furling. Use the topping lift!
- Never leave winch handle in the reefing winch - it will rotate very fast when furling the sail.
- Lock the reefing winch at the mast when reefing in heavy weather.

DINGHIES KEELBOATS YACHTS

Seldén Mast AB, Sweden
Tel +46 (0)31 69 69 00
Fax +46 (0)31 29 71 37
e-mail info@seldenmast.com

Seldén Mast Limited, UK
Tel +44 (0) 1329 504000
Fax +44 (0) 1329 504049
e-mail info@seldenmast.co.uk

Seldén Mast Inc., USA
Tel +1 843-760-6278
Fax +1 843-760-1220
e-mail info@seldenus.com

Seldén Mast A/S, DK
Tel +45 39 18 44 00
Fax +45 39 27 17 00
e-mail info@seldenmast.dk

Seldén Mid Europe B.V., NL
Tel +31 (0) 111-698 120
Fax +31 (0) 111-698 130
e-mail info@seldenmast.nl

Seldén Mast SAS, FR
Tel +33 (0) 251 362 110
Fax +33 (0) 251 362 185
e-mail info@seldenmast.fr

www.seldenmast.com

Dealer:

The Seldén Group is the world's leading manufacturer of masts and rigging systems in carbon and aluminium for dinghies, keelboats and yachts. The Group consists of Seldén Mast AB in Sweden, Seldén Mast A/S in Denmark, Seldén Mast Ltd in the UK, Seldén Mid Europe B.V. in the Netherlands, Seldén Mast SAS in France and Seldén Mast Inc in the USA. Our well known brands are Seldén and Furlex. The worldwide success of Furlex has enabled us to build a network of over 750 authorised dealers covering the world's marine markets. So wherever you sail, you can be sure of fast access to our service, spare parts and know-how.

