

1. Make sure screw ① is tightened firmly before inserting spreader end in spreader.
2. Place screw ② as shown. Select hole so that the screw can be accessed through the corresponding hole in the spreader.
3. Secure spreader end in spreader by tightening screw ② firmly with an allen key. Screw access through top hole in spreader. Screw end to protrude through bottom hole in spreader.

 **SELDÉN**

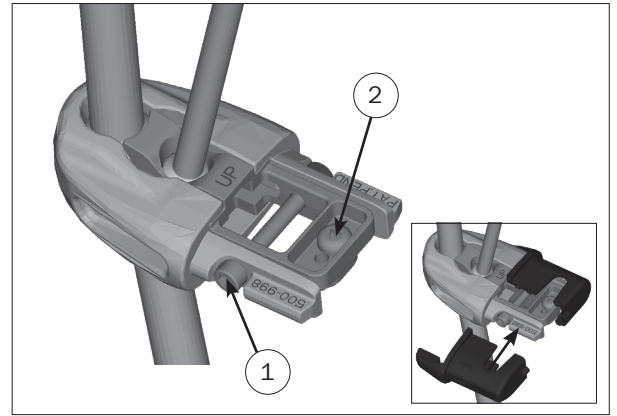

1. Make sure screw ① is tightened firmly before inserting spreader end in spreader.
2. Place screw ② as shown. Select hole so that the screw can be accessed through the corresponding hole in the spreader.
3. Secure spreader end in spreader by tightening screw ② firmly with an allen key. Screw access through top hole in spreader. Screw end to protrude through bottom hole in spreader.

 **SELDÉN**

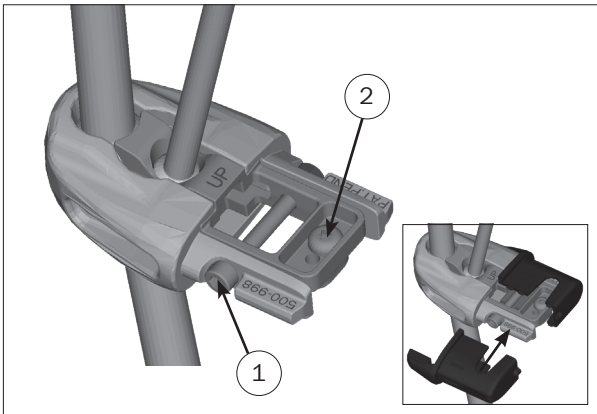

1. Make sure screw ① is tightened firmly before inserting spreader end in spreader.
2. Place screw ② as shown. Select hole so that the screw can be accessed through the corresponding hole in the spreader.
3. Secure spreader end in spreader by tightening screw ② firmly with an allen key. Screw access through top hole in spreader. Screw end to protrude through bottom hole in spreader.

 **SELDÉN**

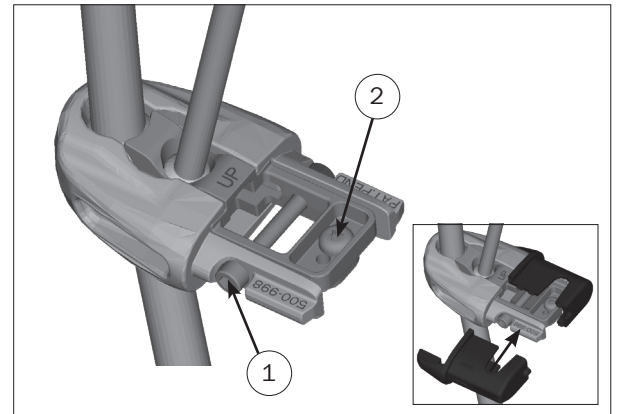

1. Make sure screw ① is tightened firmly before inserting spreader end in spreader.
2. Place screw ② as shown. Select hole so that the screw can be accessed through the corresponding hole in the spreader.
3. Secure spreader end in spreader by tightening screw ② firmly with an allen key. Screw access through top hole in spreader. Screw end to protrude through bottom hole in spreader.

 **SELDÉN**