

# Manual, Selden Hydraulic system 250 bar HPS

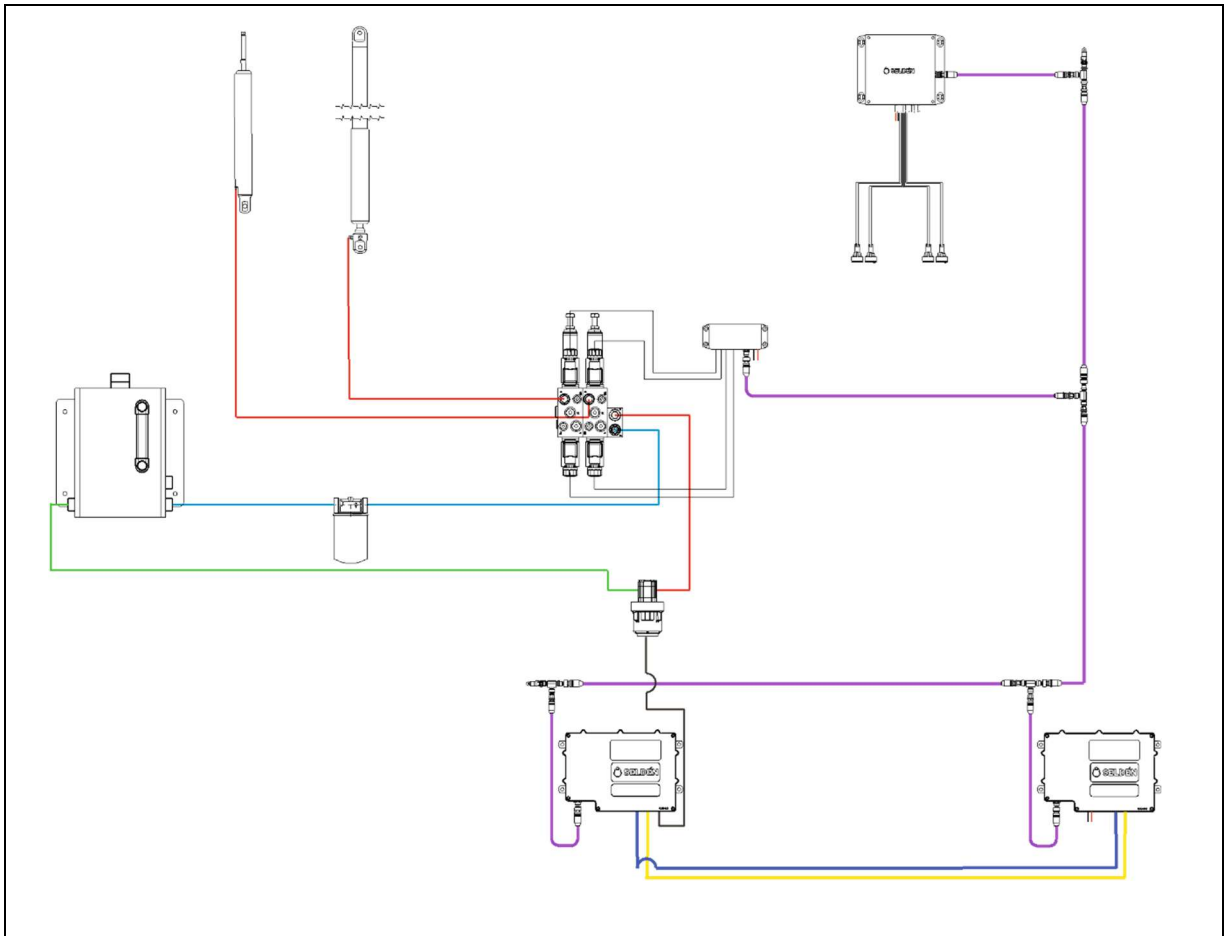

# Contents

- 1 Safety Notes ..... 4
- 2 Hydraulic System 250 bar “HPS”, Description ..... 5
  - 2.1 System Power (12 or 24V) ..... 6
  - 2.2 Power supply unit (PSU) ..... 7
  - 2.3 Motor control unit (MCU) ..... 8
  - 2.4 Pump/motor units ..... 9
  - 2.5 SEL-Bus CENTRAL CONTROL UNIT ..... 10
  - 2.6 Valve / Relay control unit ..... 12
  - 2.7 Emergency Stop ..... 14
  - 2.8 SEL-Bus Pushbutton Converter ..... 15
  - 2.9 Valve block ..... 16
  - 2.10 Pressure measurement ..... 20
  - 2.11 Pushbuttons ..... 21
  - 2.12 Tank, low pressure hose, fittings, filter ..... 21
  - 2.13 Quick release / Dump valve ..... 24
  - 2.14 High pressure hose and fittings ..... 25
  - 2.15 High / low pressure fittings ..... 28
  - 2.16 Through-deck fitting ..... 28
  - 2.17 Cylinders ..... 29
- 3 Installation ..... 31
  - 3.1 Planning ..... 31
  - 3.2 Valve block ..... 32
  - 3.3 Pump ..... 33
  - 3.4 Tank ..... 33
  - 3.5 Hoses ..... 33
  - 3.6 SEL-Bus system ..... 34
  - 3.7 PSU ..... 34
  - 3.8 MCU ..... 34
  - 3.9 Central Controller ..... 34
  - 3.10 Pushbutton converter ..... 34
  - 3.11 Valve controller ..... 35
- 4 Spare parts ..... 37
- 5 Disposal ..... 38
- 6 Warranty ..... 39

## Introduction

Congratulations on the purchase of your new Selden hydraulic system “HPS”.

This manual covers installation and operating instructions.

SEL-Bus is a Selden specific CAN-bus version. It is used to control our range of electric sail handling products, for example Furlex electric and in-mast electric furlers.

HPS (Hybrid Power System) refers to the possibility to also control hydraulics via SEL-Bus, and to give possibility for synchronized operation between hydraulic cylinders and electric motors.

The SEL-Bus system is described in the manual “597-275 Power supply and SEL-Bus system” . It explains all components necessary to power and control a system such as an electric furling system like “Furlex Electric”.

This manual explains how to add hydraulics to the SEL-Bus system to be able to control single or double acting cylinders.

Please read the entire manual before assembly/usage and keep the manual available for future reference. The latest version is available at [www.seldenmast.com](http://www.seldenmast.com).

## Related installation manuals, user guides, and product leaflets:

597-999 Central Control Unit

597-275 Power supply and SEL-Bus system

597-283 Order Guide: Power supply and SEL-Bus system

597-484 SMF retrofit kit Type RC

597-460 SMF retrofit kit type RB

597-107 Hydraulics

597-219 Emergency Stop

597-876 CYCLOPS MEASUREMENT GATEWAY BG04

## Safety Precautions

Carefully pay attention to, and follow the instructions with the following symbols:



ATTENTION









This symbol indicates a critical moment in the assembly or technical advice.



WARNING

This symbol indicates a potentially hazardous situation. If not avoided, this could result in serious personal injury or damage to property.

# 1 Safety Notes

	Never modify the electric or hydraulic components of your Seldén sail handling system.
	Installation, alterations, and maintenance should be performed by a competent marine technician.
	Never alter or modify the pre-set pressure on the hydraulic pump unit without contacting a Seldén representative for approval.
	Make sure system power is switched off before performing any installation or service.
	Never leave the craft unattended with the electric / hydraulic system powered on.
	Never touch a hydraulic hose that is pressurized.
	If a hydraulic leak is suspected, keep a safe distance. A hydraulic leak can be dangerous if the ejected oil pierces the skin. If this is suspected immediately get professional medical attention.
	Keep body parts away from any moving furling parts before or during a furling operation.

## 2 Hydraulic System 250 bar “HPS”, Description

Example showing a HPS system for backstay tensioner, synchronized mainsail furling, and hydraulic boom vang. Power is taken from the boat’s 12 or 24V battery system. The power supply units (PSU:S) transform the voltage to 42V (blue and yellow). The 42V circuit provides power for all the motors in the system.

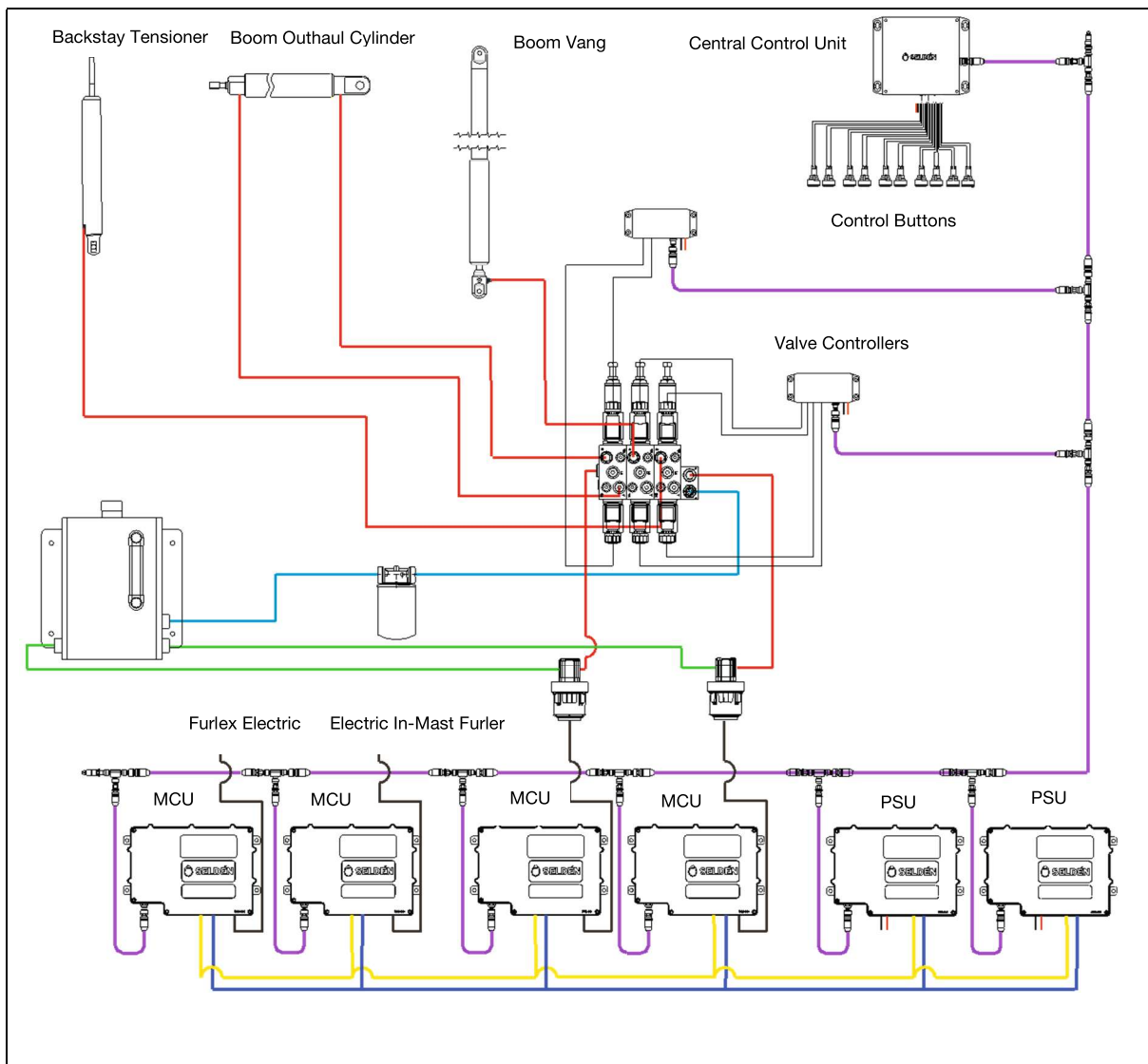

## 2.1 System Power (12 or 24V)

Each PSU (Power Supply Unit) is connected to the 12 / 24V battery with its own fuse.

It transforms power on demand and delivers it to the 42V circuit.

A main switch shall be installed in the system.

For cable dimensions and fuse specifications, please see 597-275 "Power supply and SEL-Bus system".

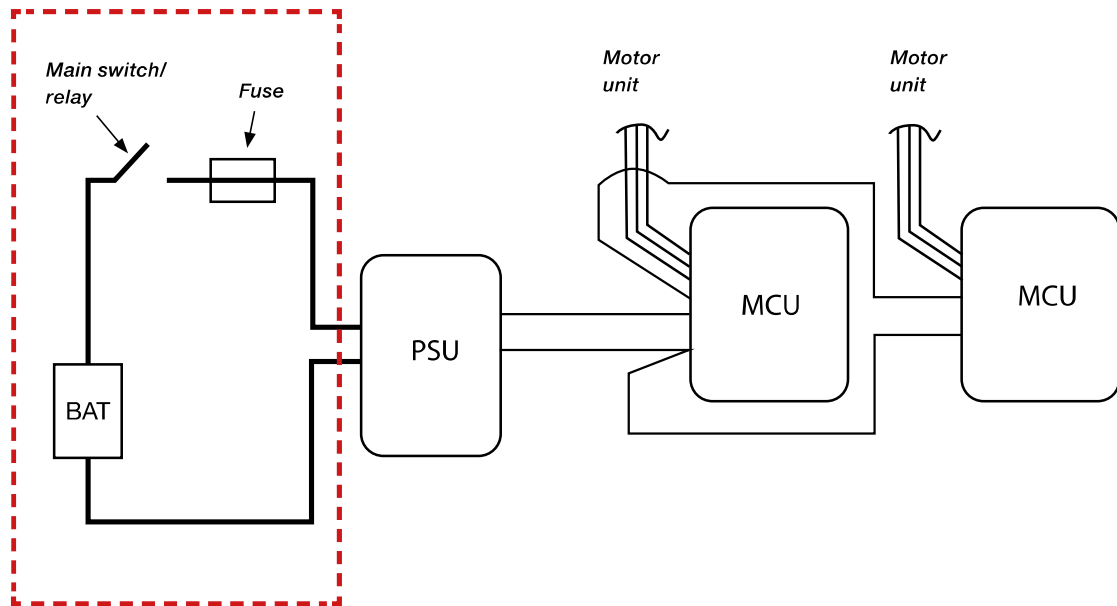









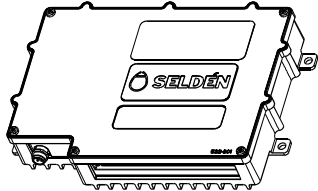
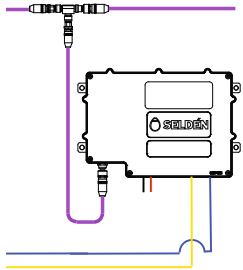

## 2.2 Power supply unit (PSU)

Provides 1-5 kW power for the 42V circuit.

More details are available in manual 597-275 “Power supply and SEL-Bus system”.

To be installed in protected environment.

Technical Data	
Input voltage	10-30 V
Fuse (12V power supply to the PSU)	100 A (Fuse with time delay), 120-160 A (Fast acting fuse)
Fuse (24V power supply to the PSU)	50 A (Fuse with time delay), 60-75 A (Fast acting fuse)
Output voltage	42V
Power consumption (sleep)	0,1 A per unit on the 42V circuit (at 12V) 0,05 A per unit on the 42V circuit (at 24V)
Power consumption (maximum)	1000 W
Efficiency	96%
Weight	1100 g

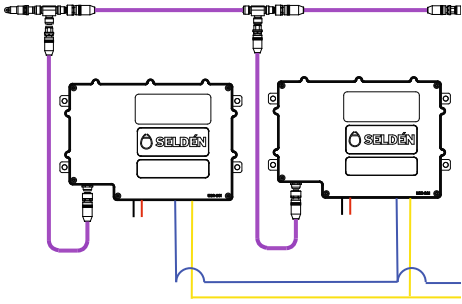
PSU							
							
Single PSU							
Single PSU installation (1 kW) 532-800-208 POWER SUPPLY UNIT, MASTER, V2							
<table border="0"> <tr> <td style="text-align: center;">  </td> <td>42V: yellow and blue</td> </tr> <tr> <td style="text-align: center;">  </td> <td>12 / 24V: black and red</td> </tr> <tr> <td style="text-align: center;">  </td> <td>SEL-Bus: purple</td> </tr> </table>		42V: yellow and blue		12 / 24V: black and red		SEL-Bus: purple	
	42V: yellow and blue						
	12 / 24V: black and red						
	SEL-Bus: purple						
Multiple PSU (2 up to 5)							
Multiple PSU installation (2-5 kW)  If two or more units (such as in-mast furler and boom outhaul cylinder) need to run simultaneously the need for power is increased. In that case more than one PSU can be added.  For multiple PSU installations one is “master” and the others (1-4) are “workers”:  532-800-208 POWER SUPPLY UNIT, MASTER, V2 532-800-209 POWER SUPPLY UNIT, WORKER V2							

## 2.3 Motor control unit (MCU)

Each motor is controlled by an MCU.

Motors are used to power electric Furlex, In-mast furling units as well as hydraulic pumps.

More details are available in manual 597-275 "Power supply and SEL-Bus system".

To be installed in protected environment.

Technical Data	
Input voltage	42 V
Power consumption (sleep)	0,1 A per unit on the 42V circuit (at 12V)
	0,05 A per unit on the 42V circuit (at 24V)
Power consumption (maximum)	1000 W
Efficiency	96%
Weight	1700 g

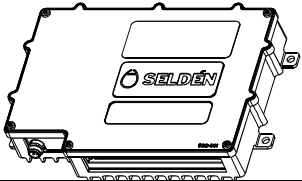
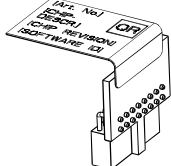
Part no	Note	
532-815-211 MOTOR CONTROL UNIT, HYDR.PUMP, V2		
532-814-211 CHIP - MEM.CARD-MCU, HYDR.PUMP, V2 The memory chip contains torque and speed settings for the motor controlled by the MCU in question.	Included in MCU, shown for information purpose	

### Dimensions (PSU / MCU)

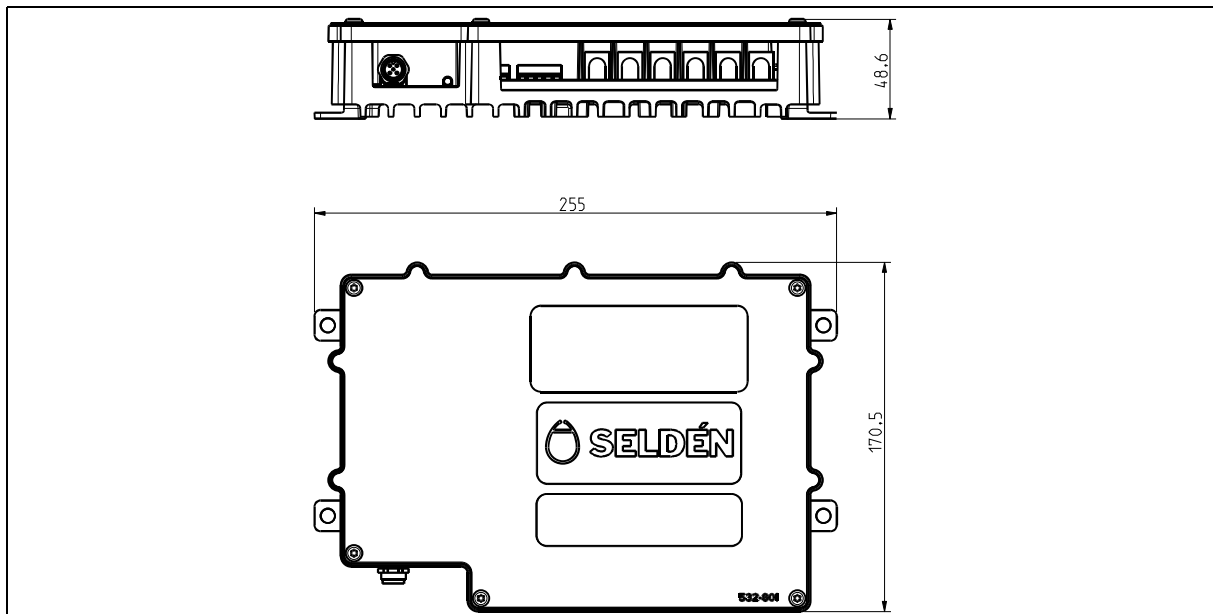

## 2.4 Pump/motor units

A brushless (BLDC) motor is used to power a hydraulic gear pump.

A bracket is integrated in the design, and rubber mounting grommets are included.

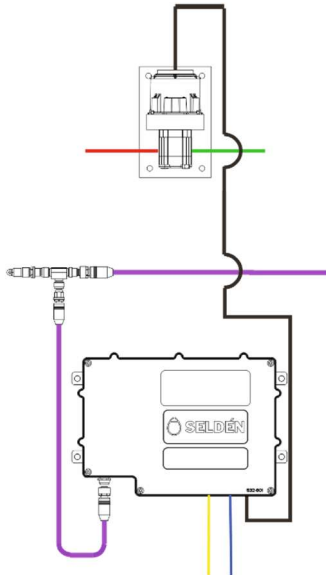
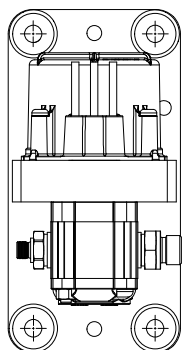
Technical data Pump / motor units	
Input voltage	42 V
Maximum power consumption	1 kW per motor
Power cables (orange, grey, brown, 2m length)	6 mm <sup>2</sup> , tinned (included with motor at delivery)
Swept volume per pump	0,57 cc/rpm
Maximum speed	8000 rpm
Flow per pump at 60 bar	4 lit/min
Flow per pump at 100 bar	2,7 lit/min
Flow per pump at 200 bar	1,5 lit/min
Flow per pump at 250 bar (maximum pressure)	0,5 lit/min
Material	Anodized aluminium / Stainless steel
Oil viscosity	ISO VG 32 or 46
Oil specification	DIN 51524 part 3, HVLP
Each pump/motor is controlled by a MCU.	
<b>587-802-01 HYDR PUMP UNIT 250 bar 197x99x117</b>  <b>FLOW 4 l/min</b>	
Weight	2700 g
Fittings in ports 60° cone, parallel BSP thread to EN ISO228-1	3/8" (Inlet port) 1/8" (Outlet port)
Height	197 mm
Width	117 mm
Depth from mounting surface	99 mm

## 2.5 SEL-Bus CENTRAL CONTROL UNIT

Programmable control unit with inputs from pushbuttons or SEL-Bus, and outputs to SEL-Bus controlled units.

Interface towards WIFI, Bluetooth, USB cable.

This component is described in detail in manual 597-999 Central Control Unit

To be installed in protected environment.

Technical Data	
Part no, Name	532-843-01 SEL-BUS CENTRAL CONTROL UNIT, V2
Voltage (Power supply)	12V +/-1 XX
Recommended cable size to coils	0.75-1.5 mm <sup>2</sup>
Fuse size	5 A
Weight	XX g
SEL-Bus connection	DeviceNet Micro-C M12 5-pole Male
Max power	XX W

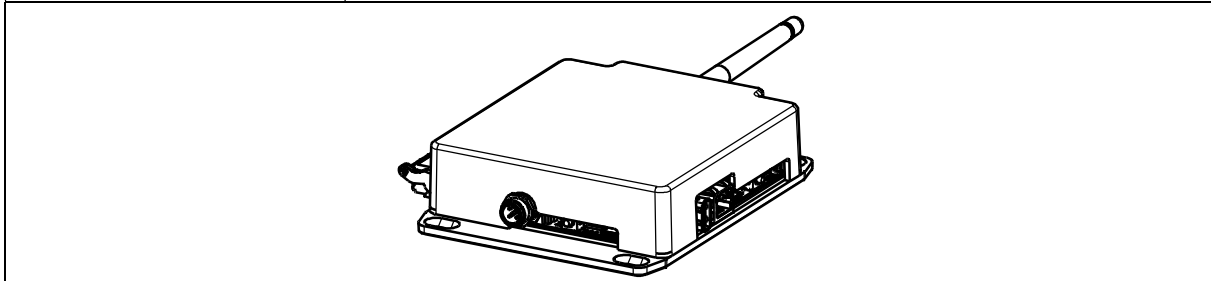

Dimensions:

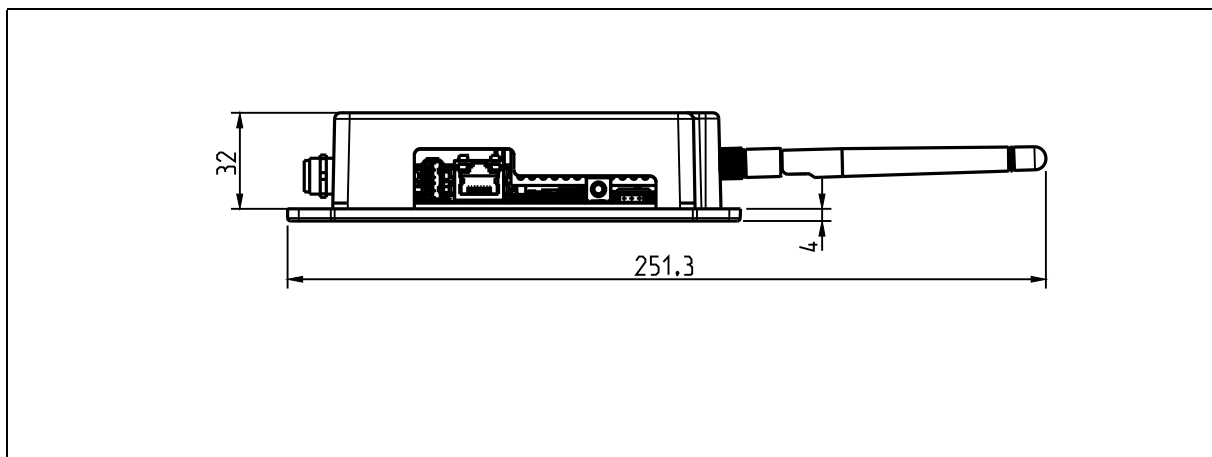

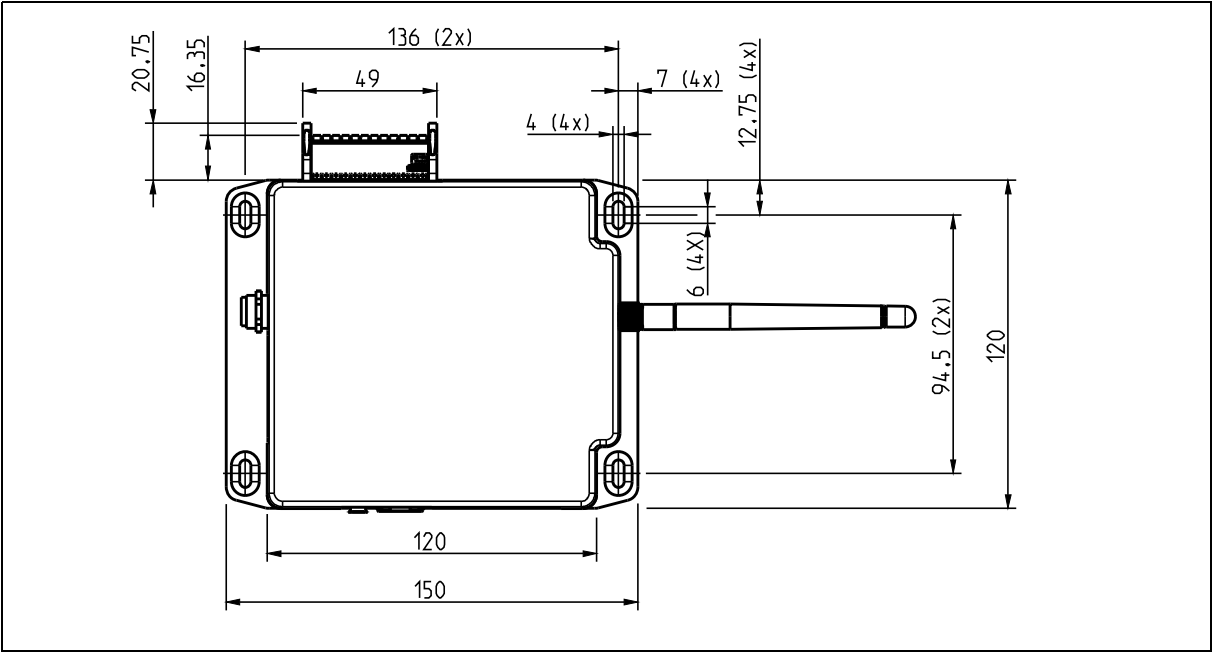

## 2.6 Valve / Relay control unit

This unit controls hydraulic valve coils from SEL-Bus. Programming can be done from the Central Controller or directly on the unit.

To be installed in protected environment.

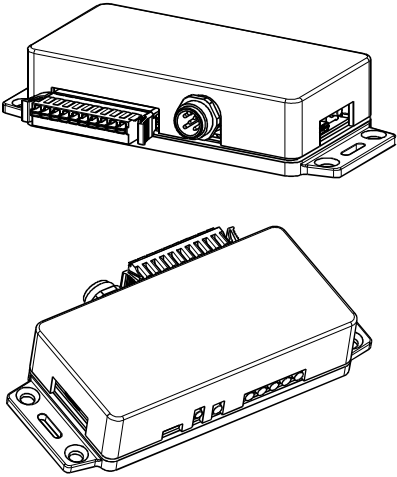
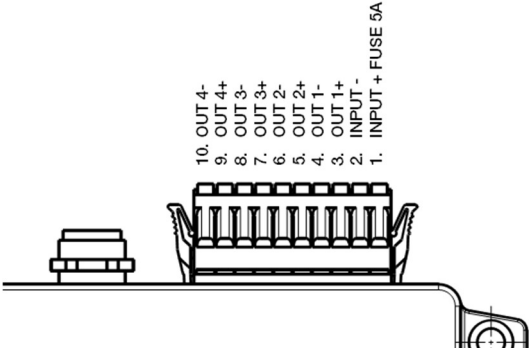
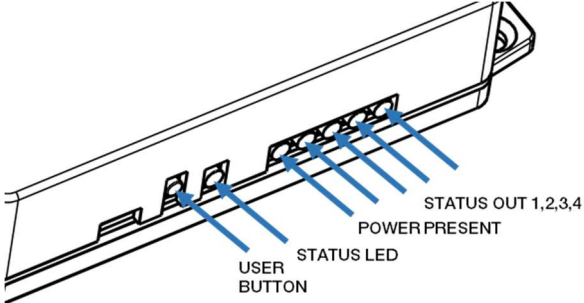
Technical Data	
Part no, Name	532-844 VALVE/RELAY CONTROL UNIT,V2. NO CONN.
Voltage	12V input => 12V output 24V input => 24V output
Recommended cable size to coils	0.75-1.5 mm <sup>2</sup>
Fuse size	5 A
Weight	90 g
SEL-Bus connection	DeviceNet Micro-C M12 5-pole Male
Max power per coil	30W
Max time for one coil to be operated	60 s.
Max time for two coils to be operated simultaneously	40 s.
532-844-10 VALVE/RELAY,CONTROL UNIT V2, NO CABLES	
<p>The outputs "OUT 1-4" control up to four coils, necessary for two hydraulic functions (for example backstay tensioner and boom vang)</p> <p>The multi cable connector can be disconnected for easier installation.</p>	
<p>"USER BUTTON" For input during installation / configuration</p> <p>"STATUS LED": For installation / troubleshooting. Colours: Red, Yellow, Violet, Blue, Dark</p> <p>"POWER PRESENT": Green = Power on, Dark = Power off</p> <p>"STATUS OUT 1-4": Violet = programming mode Blue= Output active, normal operation Dark: Output not active</p>	

Dimensions:

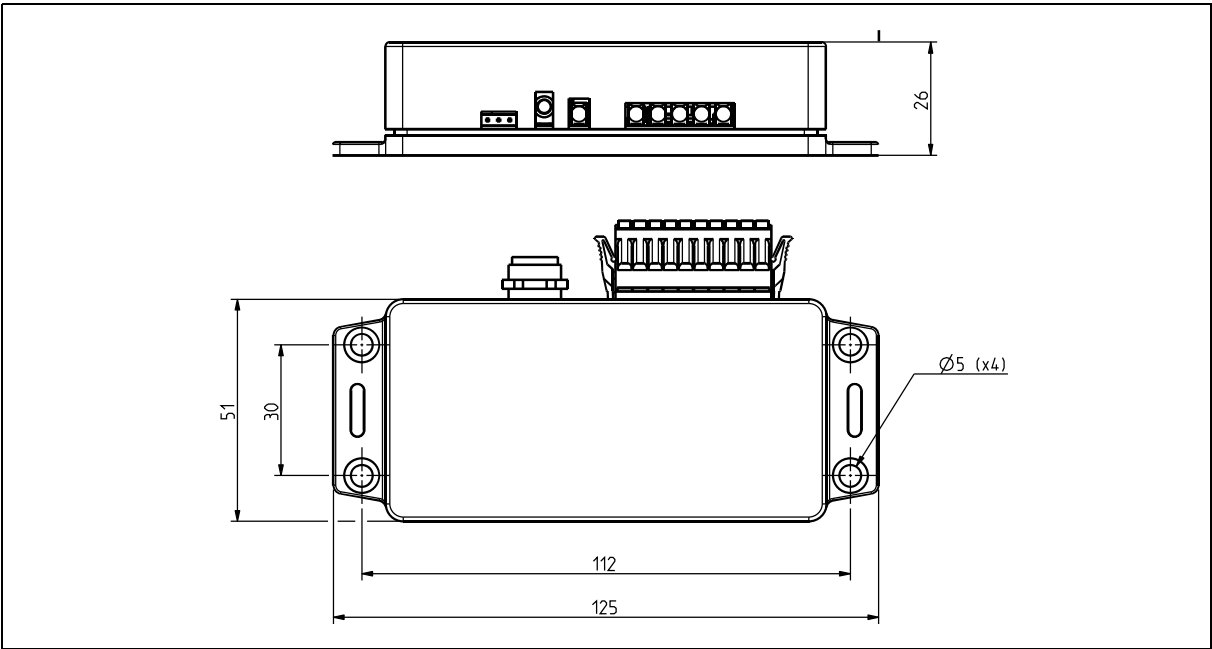

## 2.7 Emergency Stop

An emergency stop can be installed. If activated it cuts power to the PSU.

Please see manual “597-219 I: EMERGENCY STOP BUTTON / RELAY”

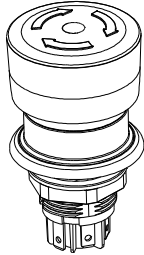
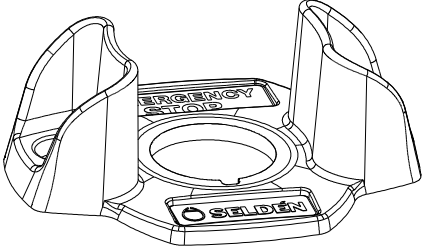
Part no	Note	
540-648 EMERGENCY STOP BUTTON		
540-649-01 GUARD FOR EMERGENCY STOP/ LABEL		
540-648-10 EMERGENCY STOP KIT, 12V 100A 540-648-20 EMERGENCY STOP KIT, 24V 100A 540-648-30 EMERGENCY STOP KIT, 12/24V 250A	Pushbutton Guard Relay Cable Terminals	

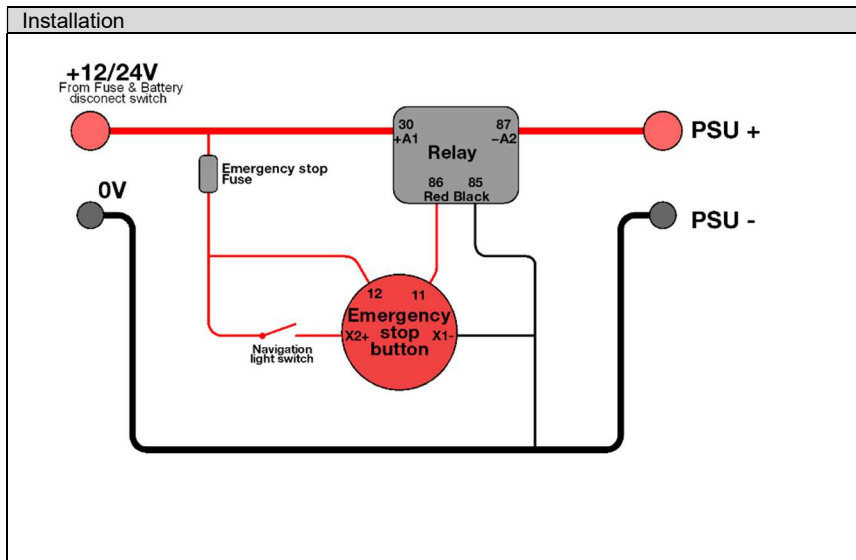

## 2.8 SEL-Bus Pushbutton Converter

The SEL-Bus converter connects a pair of pushbuttons to SEL-Bus.

See also 597-275 “Power supply and SEL-Bus system”.

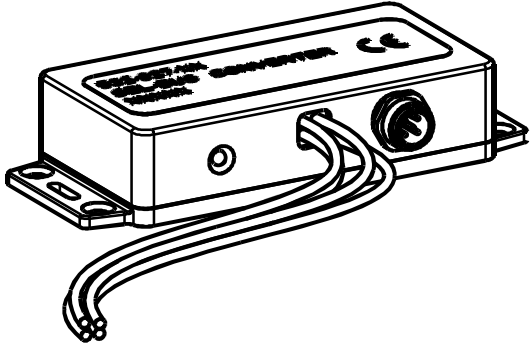
Technical Data	
532-827-201 SEL-BUS CONVERTER (BUTTONS) V2	
Cable size, length	0.75 mm <sup>2</sup> , 1.5 m
Material (casing)	PC (Polycarbonate)
Weight	90 g
SEL-Bus connection	DeviceNet Micro-C M12 5-pole Male
<p>No external power supply is necessary, it is powered by SEL-Bus.</p> <p>One converter handles a pair of pushbuttons.</p> <p>Two green cables, two red cables</p> <p>One LED for troubleshooting / status indication:</p> <p>RED (Five minutes after power on, or button being pressed) =OK</p> <p>Dark (Five minutes after power on, or button being pressed) =Fault</p>	

Dimensions:

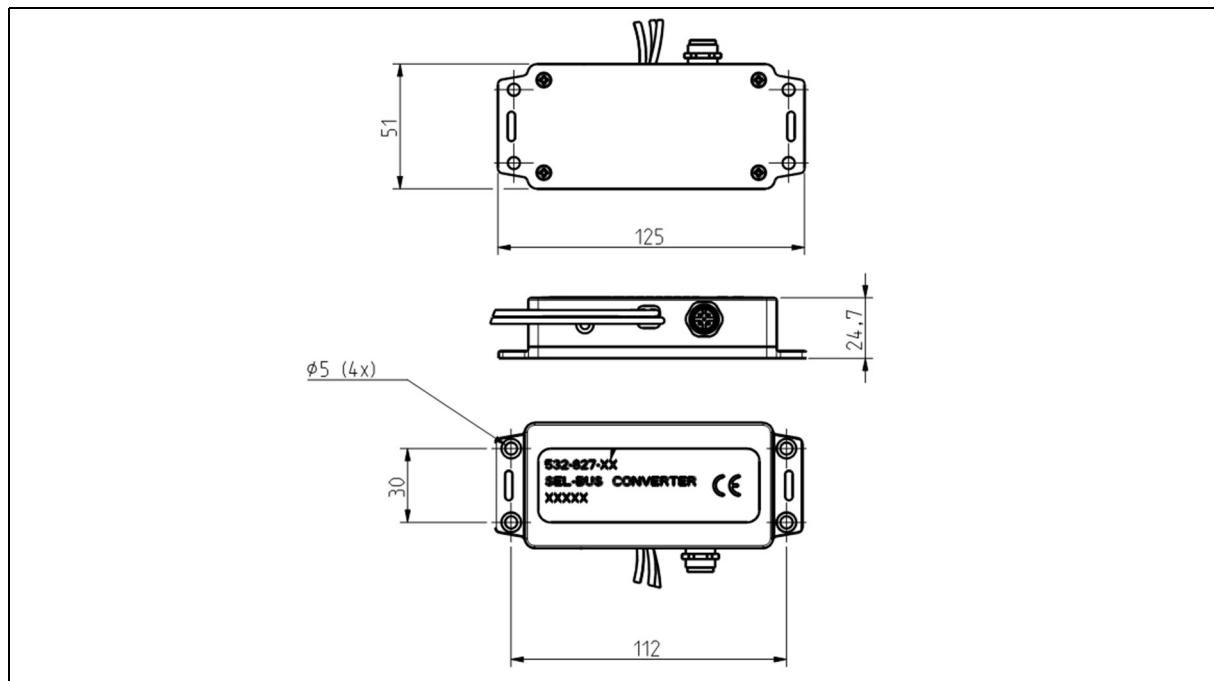

## 2.9 Valve block

Modular design, 1-7 functions.

Single and double acting cylinders can be controlled by connecting to one or two ports on the valve section.

Maximum output pressure can be set for each section / function (60-250 bar)

Modular valve block	
Voltage	12 / 24 V depending on coils
Maximum number of sections	7
Max working pressure	345 bar
Individual max pressure setting	60-250 bar
Port sizes in block	3/8" (pressure inlet from pump / return to filter/tank)
	1/4" (pressure outlet to cylinders)
	1/8" (pressure measurement ports)
Material	Steel, Zinc-Nickel treated, salt spray resistance 480h acc to DIN EN ISO 9227

No Sections / Functions	Weight [kg]
1	4,6
2	9
3	13,5
4	18
5	22,5
6	27
7	31,5

### Valve blocks

2-function shown on picture

12 / 24 V refers to the coils on the hydraulic valves.

Fittings for hoses and connectors for cables to be added in specification

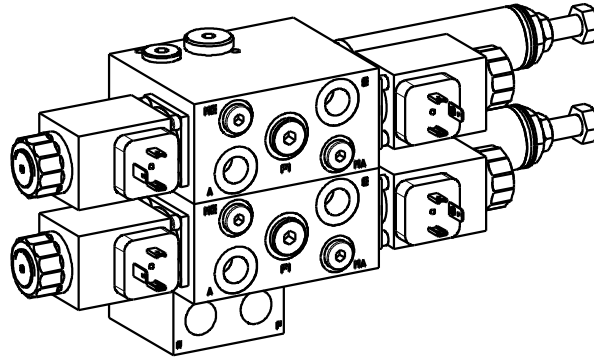

Part no	Description		
587-834-81	VALVE BLOCK, 1-FUNCTION, 12V		
587-834-82	VALVE BLOCK, 2-FUNCTIONS, 12V		
587-834-83	VALVE BLOCK, 3-FUNCTIONS, 12V		
587-834-84	VALVE BLOCK, 4-FUNCTIONS, 12V		
587-834-85	VALVE BLOCK, 5-FUNCTIONS, 12V		
587-834-86	VALVE BLOCK, 6-FUNCTIONS, 12V		
587-834-91	VALVE BLOCK, 1-FUNCTION, 24V		
587-834-92	VALVE BLOCK, 2-FUNCTION, 24V		
587-834-93	VALVE BLOCK, 3-FUNCTION, 24V		
587-834-94	VALVE BLOCK, 4-FUNCTION, 24V		
587-834-95	VALVE BLOCK, 5-FUNCTION, 24V		
587-834-96	VALVE BLOCK, 6-FUNCTION, 24V		

**Valve block for two single acting cylinders**

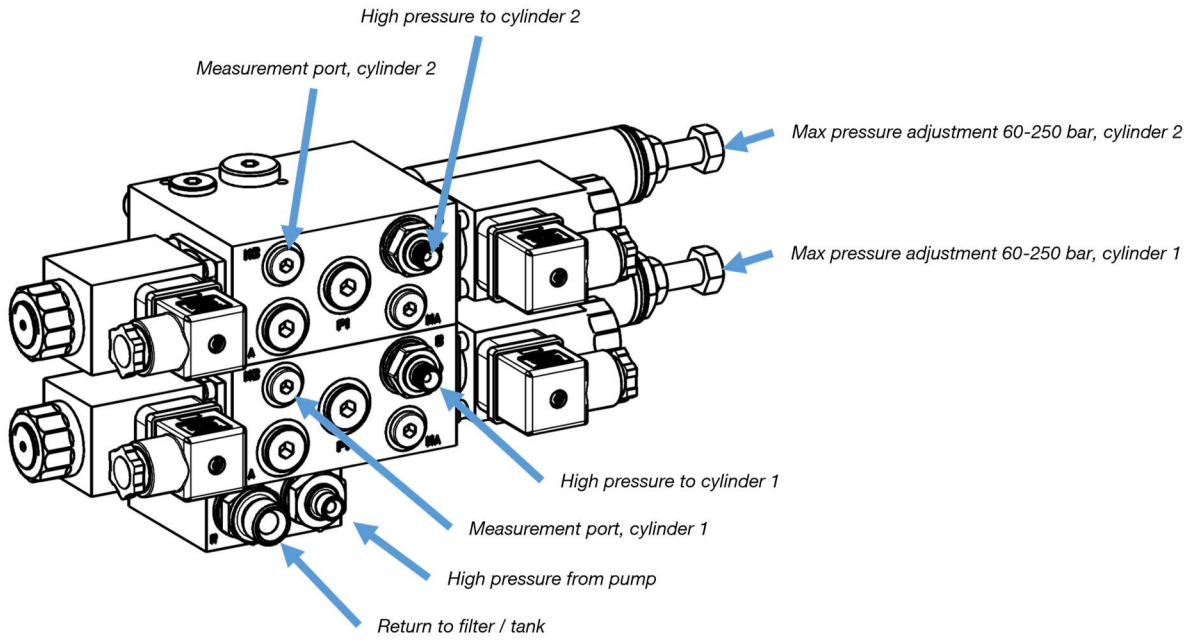

**Valve block for two double acting cylinders**

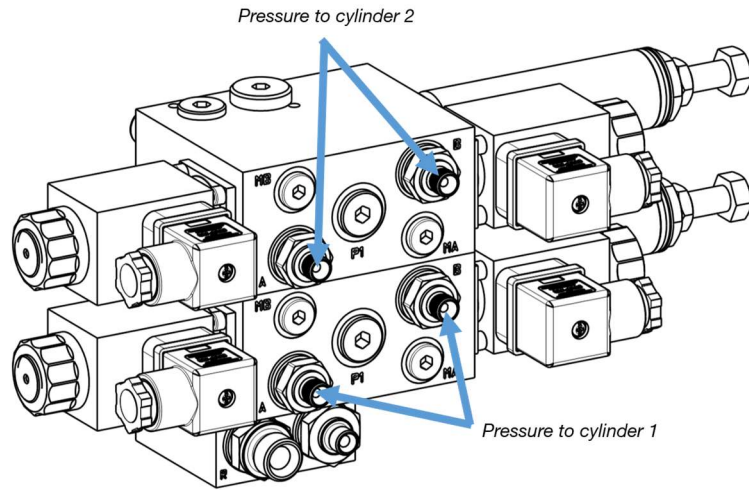

**Valve block for four single acting cylinders**

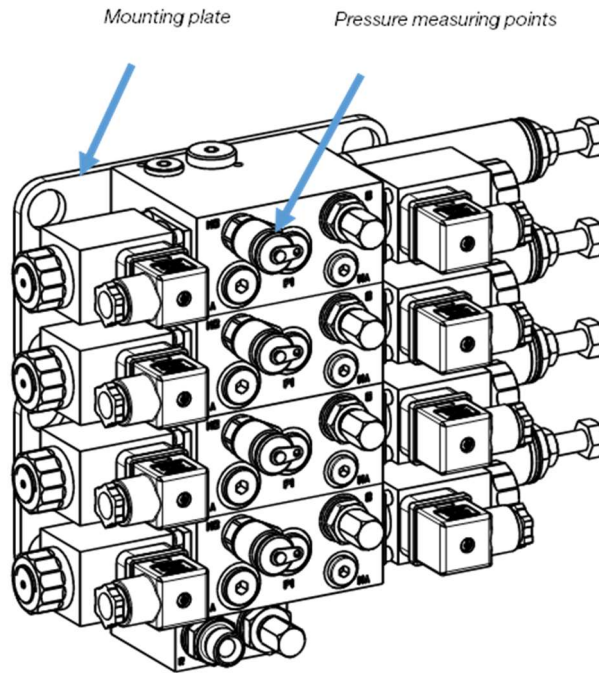

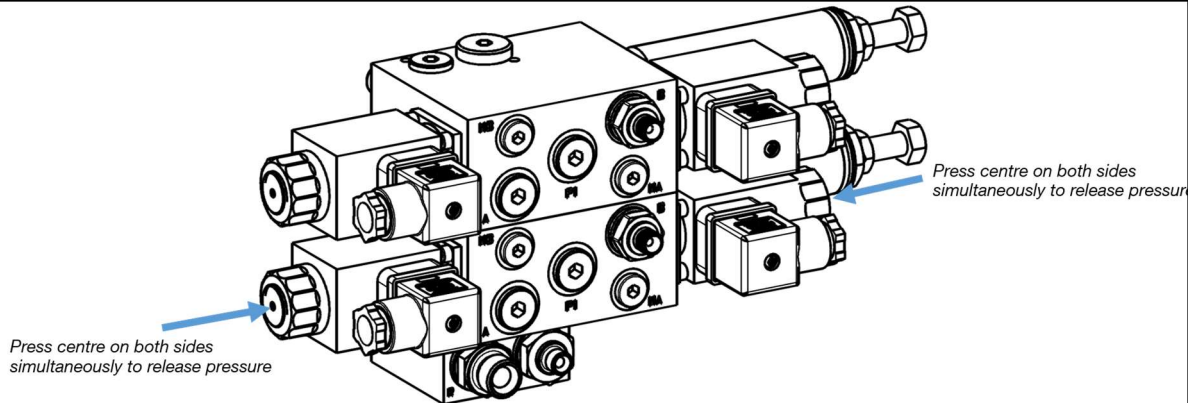

**Manual pressure release before service**

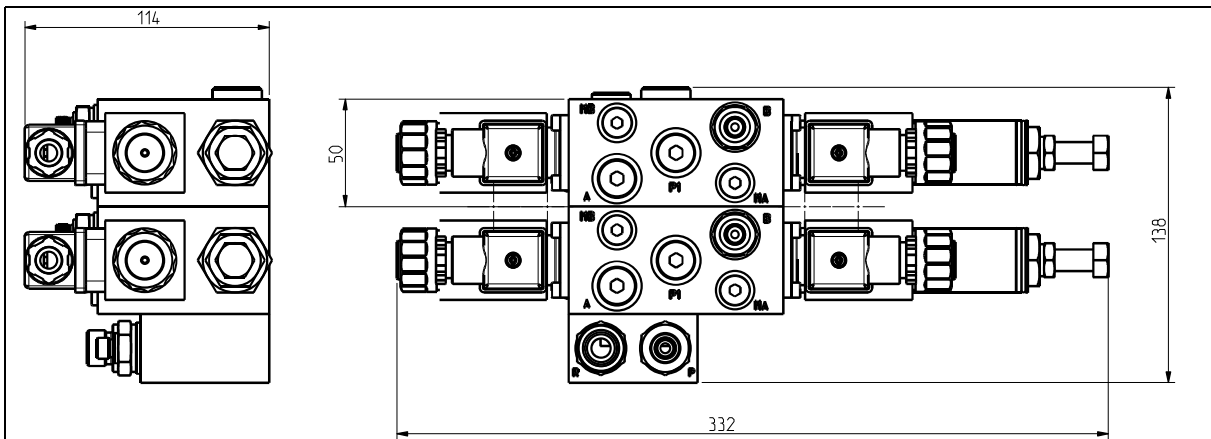

**Dimensions (two sections / functions)**

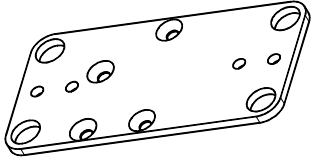
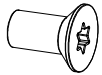
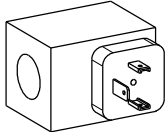
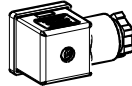
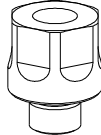

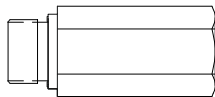
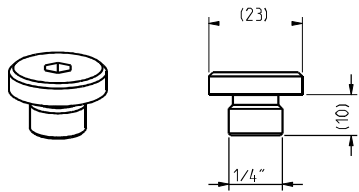
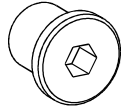
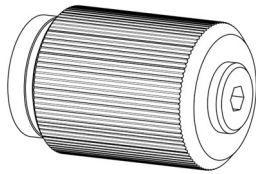
Valve block related parts		
Part no	Note	
587-807 MOUNTING PLATE 197x99x6 AL	Length=197 Width=99 Thickness 6mm	
162-033 SCREW MFT 8X16 (DIN 965T) ST	Two M8 screws per mounting plate valve block	
587-819 COIL 12V 587-821 COIL 24V	30W	
550-192 VALVE COIL CONNECTOR 12V 550-186 VALVE COIL CONNECTOR 24V	LED signal when activated	
587-826 SECOND P-PORT CONNECTOR 1/4" BVH	Adapter for an extra pressure inlet port into the valve block Material: Zinc-Nickel treated steel	
587-827 SEAL, SECOND P-PORT CONN. RUBBER	Seal washer for 587-826	
587-830 RESTRICTOR VALVE 1/4" Ø1.2	Restricts in one direction (return flow from the cylinder). Recommended on the boom vang. Seal included. Thread: BSP 1/4" both ends. Material: Zinc-Nickel treated steel	
587-829 PLUG SECOND P-PORT CONN. 1/4"	Mounted in valve block as standard (Seal: 587-827)	
587-817 PLUG 1/8"	For high pressure measuring ports. Seal included.	
587-816 PLUG 1/4"	For high pressure outlet ports. Seal included.	
587-848 VALVE OVERRIDE ( TWIST )	Used at both ends of the valve section for manual opening possibility.  HAWE T-manual override SK 7329-090/4	

## 2.10 Pressure measurement

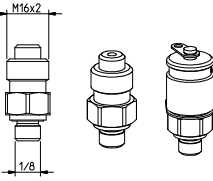
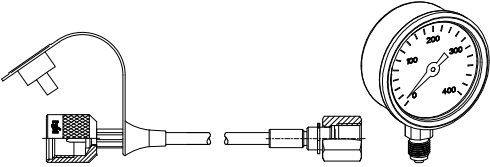
Pressure measurement		
Part no	Note	
587-822 MEASURING NIPPLE 1/8"-M16X2 FOR HAWE VALVE BLOCK	M16x2 standard test point Material: Zinc-Nickel treated steel BSP 1/8" thread fits measuring ports.	
583-502-01 PRESSURE GAUGE +TEST HOSE M16X2	63mm pressure gauge Hose length 1m M16x2 connection for test point	

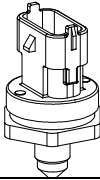
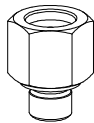
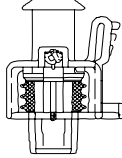
Pressure measurement, electronic, sensor kit			
Assembly no	Included parts		
583-505-01 PRESSURE SENSOR SET, ELECTRONIC	583-505 PRESSURE SENSOR, ELECTRONIC		
	585-642 ADAPTER M10X1 / BSP 1/8" ZN-NI	Adapter towards valve block (1/8") Seal included	
	532-201-01 CONNECTOR ASSY, CYCLOPS GATEWAY	-Connector including 3x 2m cables (1mm <sup>2</sup> ) red, black, green	

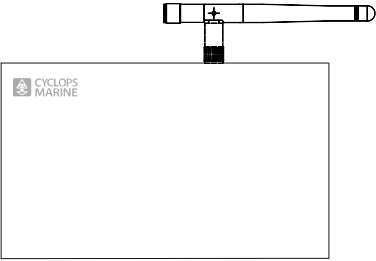
Load / Pressure sensor gateway		
Part no	Note	
532-200 LOAD MEASUREMENT GATEWAY, CYCLOPS BG04	<p>Eight channel gateway. Receives signals via cables, or wireless. It can show the pressure value in the navigation system, on a computer, or on a smartphone. Please also see manual 597-876 "CYCLOPS MEASUREMENT GATEWAY BG04".</p> <p>Technical data:</p> <ul style="list-style-type: none"> <li>• 2.4 Ghz and 5.0 Ghz IEEE 802.11ac wireless, Bluetooth 5.0, BLE</li> <li>• NMEA 2000 compatible</li> <li>• Power supply either from 12V or from the NMEA2000 bus</li> <li>• Dimensions: 174x110x32 mm</li> <li>• Weight: 370g</li> <li>• Material: Anodized Aluminium / Flame Retardant ABS</li> <li>• IP rating: 54</li> <li>• Clock Battery: 10 years, CR2032</li> </ul>	

## 2.11 Pushbuttons

For more information, please see “597-283 Order guide Seldén Power Supply and SEL-Bus system”

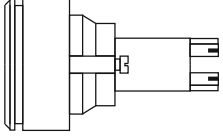
Description	Selden Part no	Note	
PUSHBUTTON "RED"	540-460-05	One pushbutton Normally open	
PUSHBUTTON "GREEN"	540-459-05		

Only use a pushbutton that returns to its original open position when released. Otherwise, functionality will be lost when controlling SEL-Bus units (high/low speed)

## 2.12 Tank, low pressure hose, fittings, filter

3x suction / return ports to ISO 228-1 (G1/2" / BSPP)

- 1) Fittings with rubber seal “Dowty” washer

Example:

540-902 HYDR.SEAL WASHER 1/2 ST.ST  
 585-649 NIPPLE P-LOK BSPP NUT 1/2" HOSE 1/2" ST  
 585-703 HYDR.HOSE, PUSH-LOK 1/2"  
 585-309 HOSE CLAMP Ø20 PA

- 2) BSPT conical threads plus Teflon tape

Example:

585-666 NIPPLE BSPT 1/2", HOSE 1/2" ST + Teflon tape  
 585-309 HOSE CLAMP Ø20 PA  
 585-703 HYDR.HOSE, PUSH-LOK 1/2"

Ventilated cap with splash protection and filter

Hydraulic Reservoir Tank			
Description	Part no	Max Volume [L]	Useable Volume 25-85% [L]
HYDR.RESERVOIR TANK 6L+CAP	585-311-01	6	3,6
HYDR.RESERVOIR TANK 11L+CAP	585-310-01	11	6,6

**Dimensions**

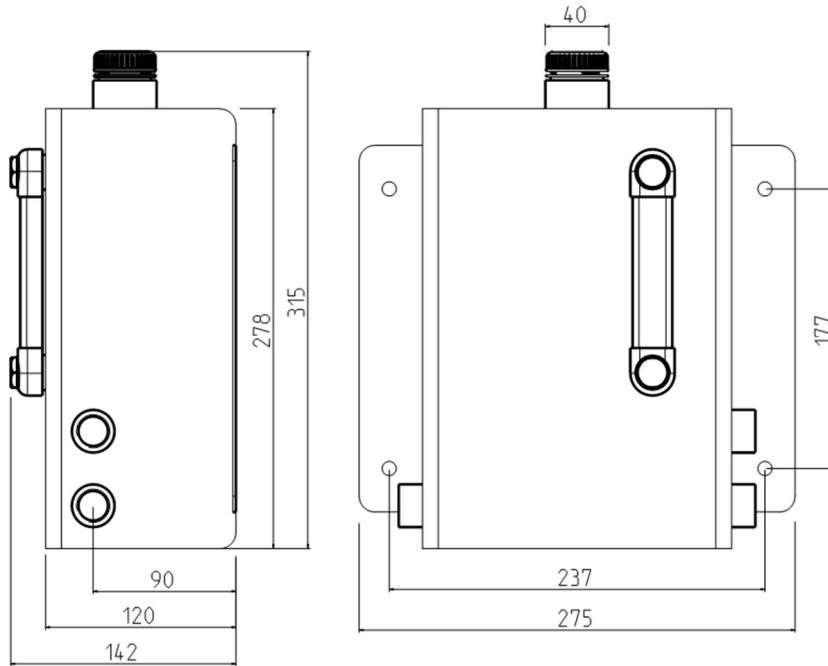

HYDR.RESERVOIR TANK 6L+CAP 585-311-01

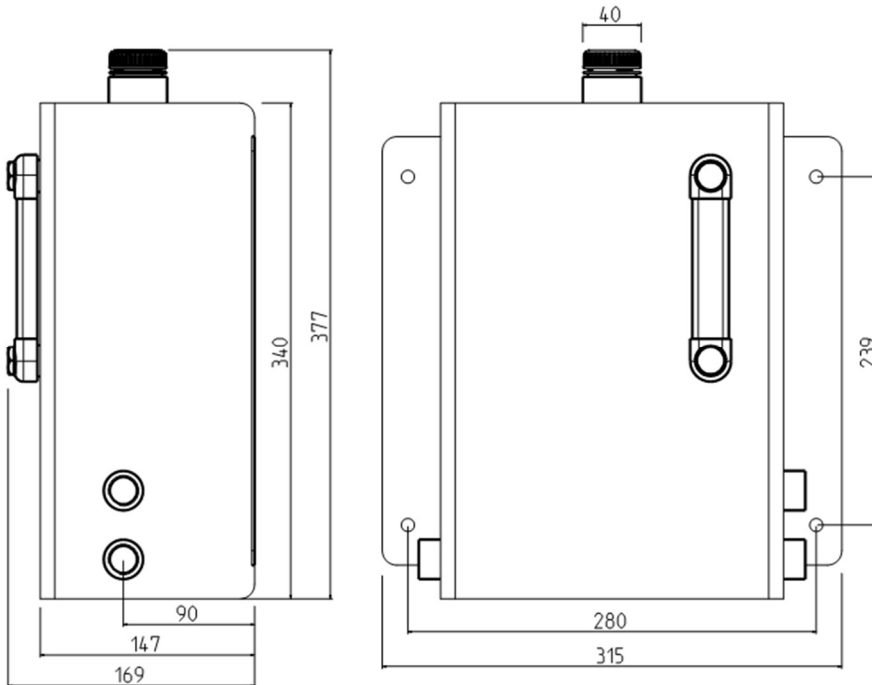

**Dimensions**

HYDR.RESERVOIR TANK 11L+CAP 585-310-01

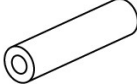
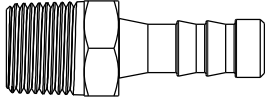

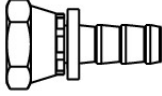
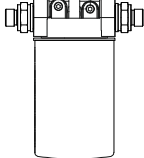
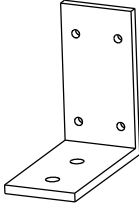
Low pressure hose and fittings	Note	
585-700 HYDR.HOSE, PUSH-LOK 1/4"	Max pressure 20 bar	
585-701 HYDR.HOSE, PUSH-LOK 3/8"		
585-703 HYDR.HOSE, PUSH-LOK 1/2"		
585-686 NIPPLE BSPT 1/2", HOSE 1/4" ST	Stainless steel AISI 316, for tank ports. Teflon tape to be used	
585-662 NIPPLE BSPT 1/2", HOSE 3/8" ST		
585-666 NIPPLE BSPT 1/2", HOSE 1/2" ST		
585-306 HOSE CLAMP Ø13 PA	Nylon, for 1/4" hose	
585-307 HOSE CLAMP Ø15 PA	Nylon, for 3/8" hose	
585-309 HOSE CLAMP Ø20 PA	Nylon, for 1/2" hose	
585-640 NIPPLE P-LOK BSPP NUT 3/8" HOSE 3/8" ST	Stainless	
585-652 NIPPLE P-LOK BSPP NUT 3/8" HOSE 3/8" C.ST	Carbon steel, zinc coated	
585-649 NIPPLE P-LOK BSPP NUT 1/2" HOSE 1/2" ST	Stainless	
585-653 NIPPLE P-LOK BSPP NUT 1/2" HOSE 1/2" C.ST	Carbon steel, zinc coated	
550-134-02 FILTER+HOUSE (1/4" NIPPLES)	Filter element : Micro-fibre glass	
550-134-01 FILTER+HOUSE (3/8" NIPPLES)	Degree of filtration: 10 µm	
550-134-03 FILTER+HOUSE (1/2" NIPPLES)		
550-199 FILTER BRACKET	Aluminium	

## 2.13 Quick release / Dump valve

Used for quick release of the boom vang. A manifold with an electric poppet valve is added to the pressure line. When the valve opens, the pressurized oil returns to the tank.

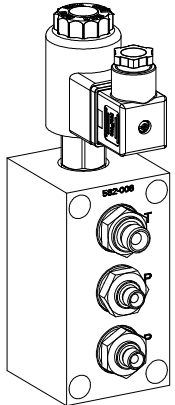

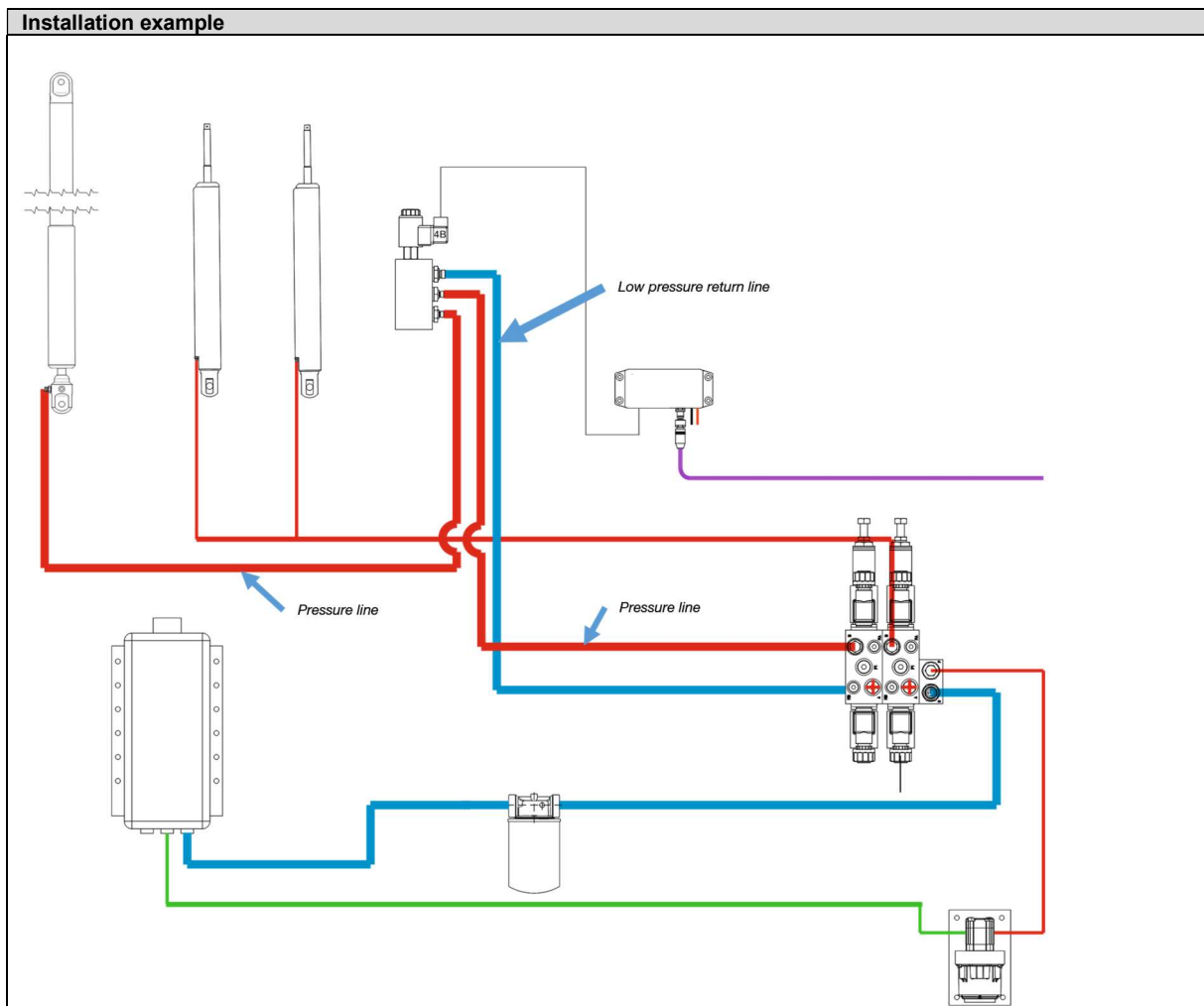
Hydraulic Valve	Voltage	
582-006-12 DUMP VALVE, HOSE 1/8" -12V (345 BAR)	12	
582-006-24 DUMP VALVE, HOSE 1/8" -24V (345 BAR)	24	

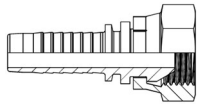
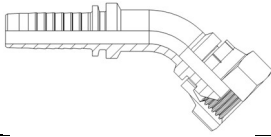
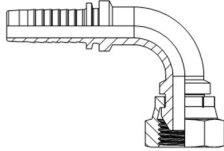

## 2.14 High pressure hose and fittings

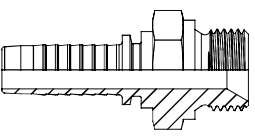
<b>FITTINGS WITH NUT, INTERNAL THREADS</b>			
BSPP fittings ,60° cone, internal parallel BSP thread to EN ISO 228-1			
			
			
<b>Part No</b>	<b>High pressure hose, size</b>	<b>Internal thread on nut</b>	<b>Angle</b>
585-606 HY.COUPL. 1/8NUT, 1/4HSE 0° ST	1/4"	1/8"	0°
585-607 HY.COUPL. 1/8NUT, 1/4HSE 45° ST	1/4"	1/8"	45°
585-608 HY.COUPL. 1/8NUT, 1/4HSE 90° ST	1/4"	1/8"	90°
540-911 HYDR COUPLING 1/4 NUT 0° ST	1/4"	1/4"	0°
540-912 HYDR.COUPLING 1/4 NUT 45° ST	1/4"	1/4"	45°
540-913 HYDR.COUPLING 1/4 NUT 90° ST	1/4"	1/4"	90°
550-389 HYDR.COUPL. 1/4NUT, 5/16HOSE 0° ST	5/16"	1/4"	0°
550-390 HYDR.COUPL. 1/4NUT, 5/16HOSE 45° ST	5/16"	1/4"	45°
550-391 HYDR.COUPL. 1/4NUT, 5/16HOSE 90° ST	5/16"	1/4"	90°
540-963 HYDR.COUPLING 3/8 NUT 0° ST	3/8"	3/8"	0°
540-927 HYDR.COUPLING 3/8 NUT 45° ST	3/8"	3/8"	45°
540-915 HYDR COUPLING 3/8 NUT 90° ST	3/8"	3/8"	90°

FITTINGS WITH EXTERNAL THREAD		
BSPP fittings ,60° cone, external parallel BSP thread to EN ISO 228-1		
Part No	High pressure hose, size	External thread
540-909 HYDR.COUPLING 1/4 MALE 0° ST	1/4"	1/4"
550-392 HYDR.COUPL. 1/4, 5/16HOSE 0° ST	5/16"	1/4"
540-914 HYDR.COUPLING 3/8 MALE 0° ST	3/8"	3/8"
585-608 HY.COUPL. 1/8NUT, 1/4HSE 90° ST	1/2"	1/2"

High pressure hose and swaging ferrules	Note		
540-965 HYDR.HOSE 1/4" KEVLAR	STD: SAE 100R8 Max working pressure 345 bar		
540-954 HYDR.HOSE 5/16" R8, 345 BAR			
540-871 HYDR.HOSE 3/8" R8, 345 BAR			
540-919 CLAMP HYDR.HOSE 1/4" ST			
550-393 CLAMP HYDR.HOSE 5/16" ST			
540-920 CLAMP HYDR.HOSE 3/8" ST			

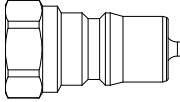
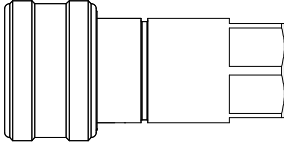
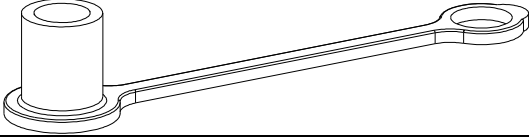
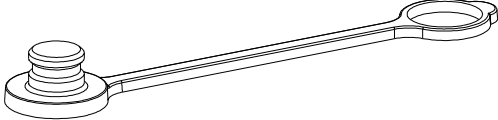
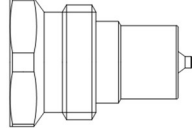
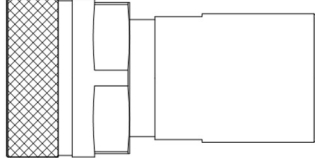
HIGH PRESSURE QUICK CONNECTORS + PROTECTION CAPS		
Part No	Note	
585-630 COUPLING Q-ACT 1/4"(MALE) ISO-B ST	Max working pressure 345 bar	
585-631 COUPLING Q-ACT 1/4"(FEMALE) ISO-B ST	Max working pressure 345 bar	
585-657 DUST CAP 1/4" FEMALE, -ISO-B (FOR 585-630)	SOFT PVC	
585-658 DUST CAP 1/4" MALE, -ISO-B (FOR 585-631)	SOFT PVC	
585-663 COUPLING Q-ACT 3/8"(MALE) 345BAR ST		
585-664 COUPLING Q-ACT 3/8"(FEMALE) 345BAR ST		

## 2.15 High / low pressure fittings

Compatible with low and high pressure hoses

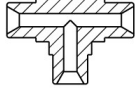
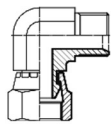
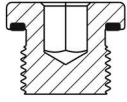
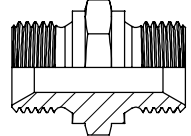
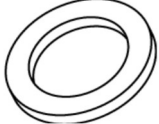
High / low pressure fittings	Max Pressure	
585-643 T-ADAPTOR BSPP 3/8" 60° CONE ST	Max pressure 345 bar, stainless	
540-979 ADAPTOR 3/8 90° (MLE-NUT) C.ST	Max pressure 345 bar, carbon steel, zinc coated	
540-980 ADAPTOR 1/2 90° (MLE-NUT) C.ST		
585-615 PLUG 1/8" ST	Max pressure 345 bar, stainless, seal included	
550-316 PLUG 1/4" ST		
550-323 PLUG 3/8" ST		
550-310 PLUG 1/2" ST		
585-611	NIP.BSPP1/8-BSPP1/4 60° CONE ST	
540-881	NIPPLE 1/4"-1/4" ST	
540-923	NIPPLE 3/8-1/4 ST	
540-976	NIPPLE G3/8-1/4 C.ST	
540-899	NIPPLE G3/8-3/8 ST	
540-977	NIPPLE G3/8-3/8 C.ST	
540-978	NIPPLE G1/2-3/8 C.ST	
540-982	NIPPLE G1/2-1/2 C.ST	
585-616	HYDR.SEAL WASHER 1/8" ST	
540-885	HYDR.SEAL WASHER 1/4" ST	
540-900	HYDR.SEAL WASHER 3/8 ST	
540-902	HYDR.SEAL WASHER 1/2 ST.ST	
540-971	HYDR.SEAL WASHER 3/4 C.ST	

## 2.16 Through-deck fitting

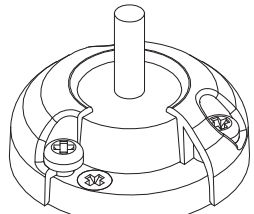
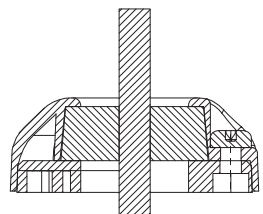
Through-deck fitting			
532-168 CABLE GLAND INDEX DG22, ST	Polished stainless steel  Hose diameter 9-14mm  Maximum fitting diameter of fitting that needs to pass through cover = 21mm  Outer diameter 49mm		

## 2.17 Cylinders

Single / double acting cylinders can be controlled by the HPS system.

For more details, please see 597-107 “Hydraulics”

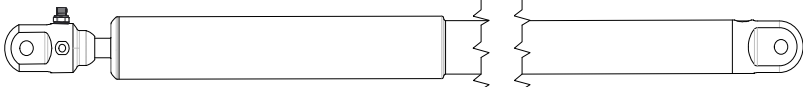
Hydraulic boom vang							
							
Description	Part no	Pulling force [250 bar]	Pulling force [345 bar]	Return force	Hole size	Oil port in fork	Oil volume difference contracted / extended rod
HV-46 Vang, Clear	580-033-10	31 kN	44 kN	8,4 kN	16	1/4"	0,44 lit
HV-46 Vang, Black	580-034-10						
HV-69 Vang, Clear	580-035-10	46 kN	57 kN	12,2 kN	19	1/4"	0,65 lit
HV-69 Vang, Black	580-036-10						
HV-106 Vang, Clear	580-041-10	71 kN	106 kN	19 kN	22	3/8"	1,1 lit
HV-106 Vang, Black	580-042-10						
HV-89 Vang, Clear	580-035-10	89 kN	138 kN	24,4 kN	25	3/8"	1,6 lit
HV-89 Vang, Black	580-036-10						

Tensioner								
								
Description	Part no	Pulling force [250 bar]	Pulling force [345 bar]	Thread [rod]	Hole size	Oil port	Fitting towards hose	Oil volume difference contracted / extended rod
HT-W8/10, Clear	580-003-10	32 kN	44 kN	5/8" UNF LH	16	1/8"	1/8"	0,56 lit
HT-W8/10, Black	580-004-10							
HT-W12/14, Clear	580-007-10	61 kN	85 kN	7/8" UNF LH	22	1/8"	1/8"	1,12 lit
HT-W12/14, Black	580-008-10							

**Double acting (main outhaul, main sheet)**

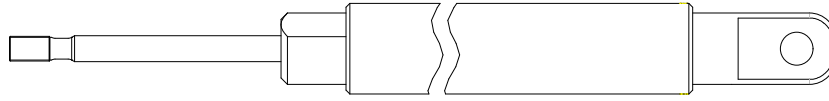

Description	Part no	Pulling force at 250 bar	Pulling force at 345 bar	Thread	Hole size	Ports in cylinder	Connection towards hoses (fitting)	Hose size	Oil volume difference contracted rod / extended rod
CYL. Ø67/50, 345 BAR, STROKE 1800	580-029-01	41 kN	57 kN	3/4" UNF RH	25,3	1/4"	1/8"	1/4"	0,56
CYL. Ø67/50, 345 BAR, STROKE 2200	580-030-01	41 kN	57 kN	3/4" UNF RH	25,3	1/4"	1/8"	1/4"	0,69
CYL. Ø79/60, 345 BAR, STROKE 2200	580-038-01	58 kN	81 kN	M24x2	25,3	3/8"	1/4"	3/8"	0,69
CYL. Ø79/60, 345 BAR, STROKE 2600	580-039-01	58 kN	81 kN	M24x2	25,3	3/8"	1/4"	3/8"	0,75

# 3 Installation

The hydraulic system should be professionally installed.

## 3.1 Planning

The tank should be placed higher than the pump to promote flow.

The low-pressure suction hoses from the tank to the pump should be kept as short as possible.

This also applies to the return hoses from the valve block to the tank.

Cleanliness is very important in hydraulic systems. A 10 µm return filter is recommended.

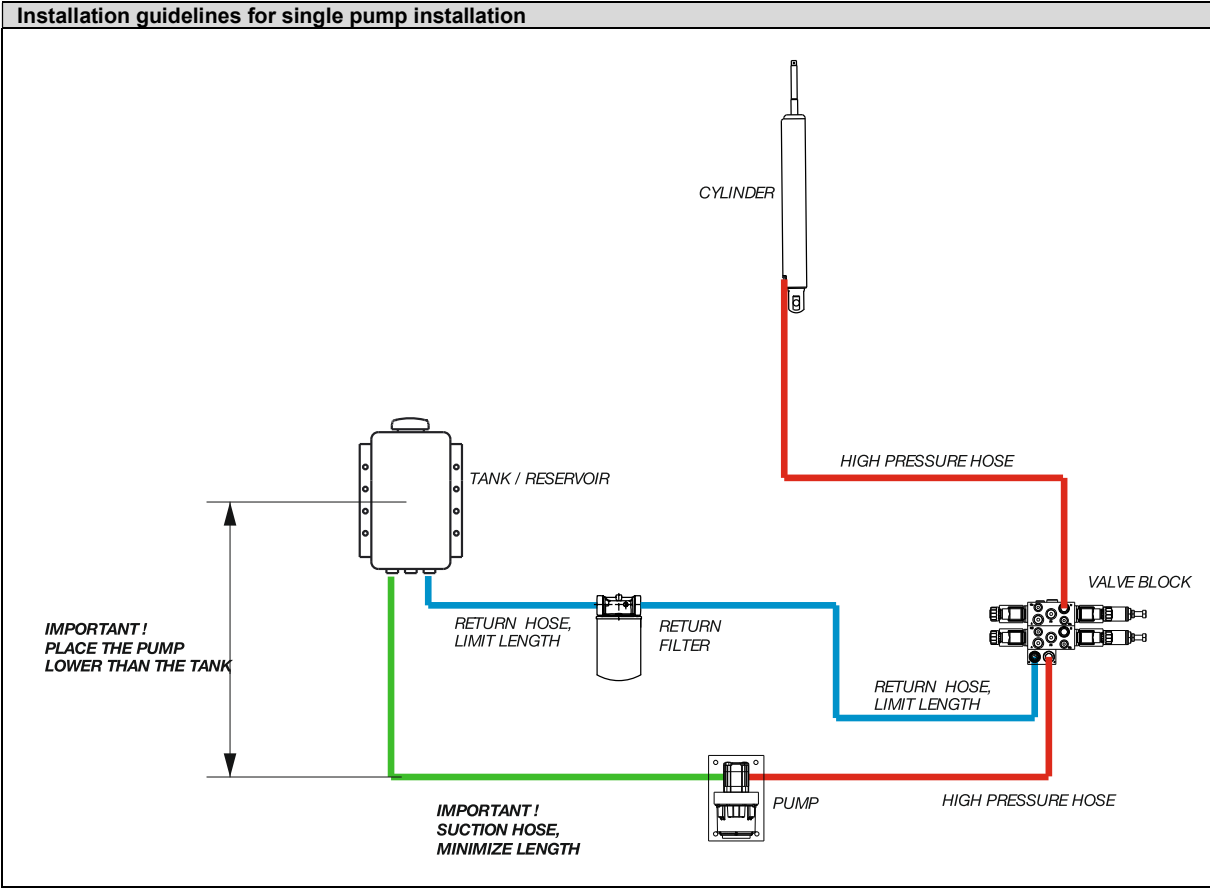

### Installation guidelines for double pump installation

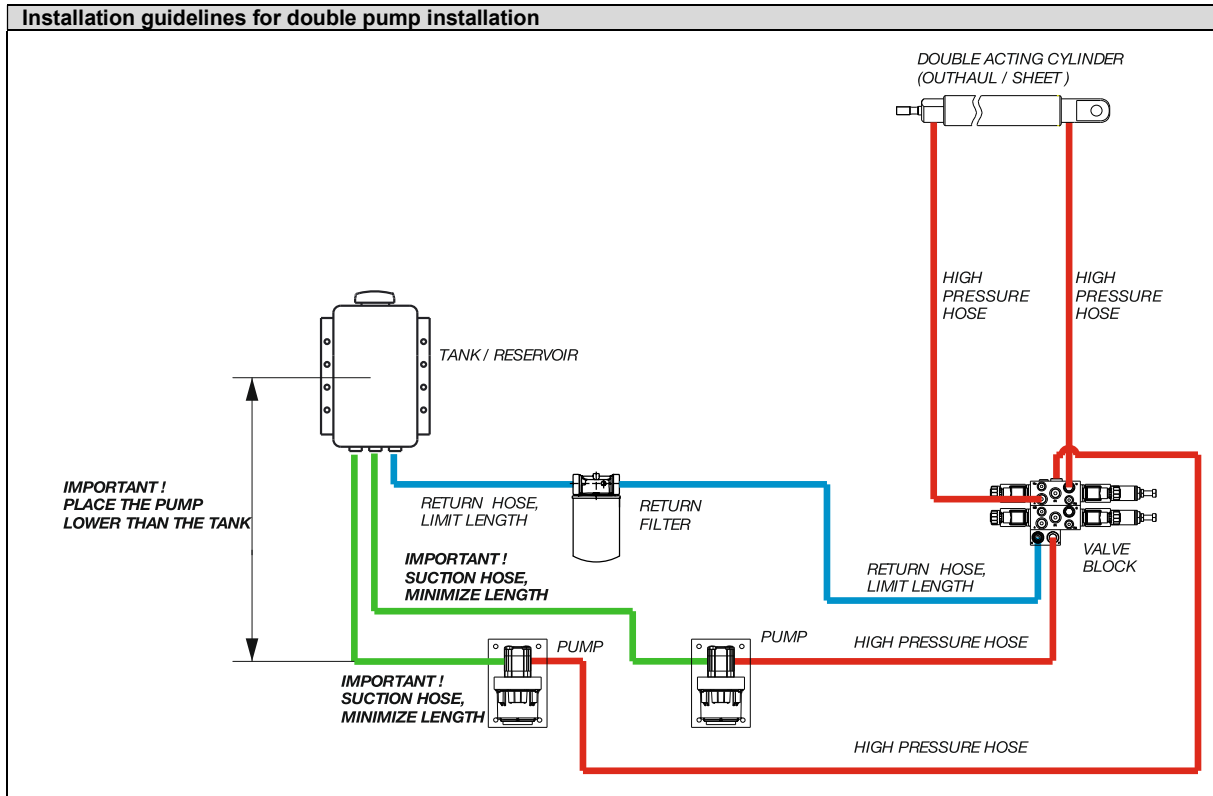

## 3.2 Valve block

The valve block shall be placed with space around it, for good access to the fittings, and to be able to replace the valve coils.

### 3.3 Pump

The recommended orientation is with the pump downwards.

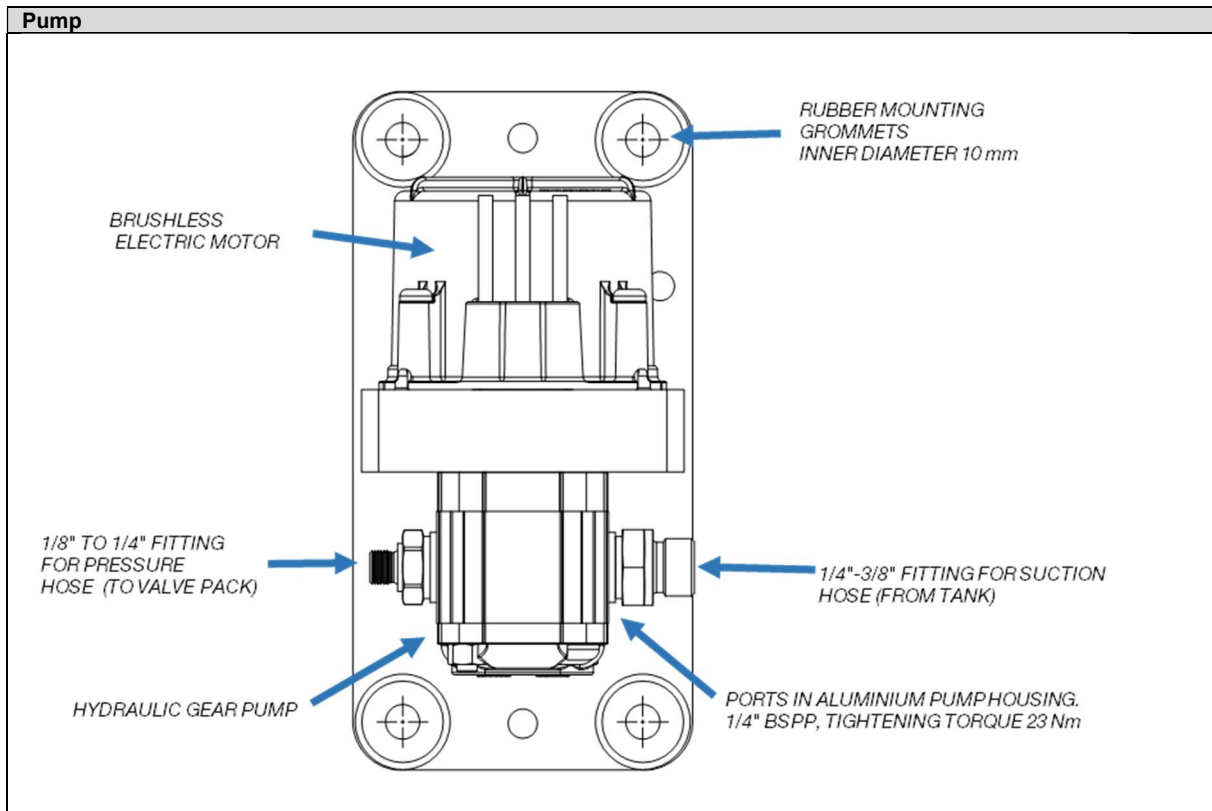

### 3.4 Tank

The tank shall be placed so that the cap can be removed, and oil can be refilled.

The tank has NPT 3/8" conical threads. We offer Nylon fittings that match.

We recommend using Teflon tape on these fittings, but not anywhere else in the system.

### 3.5 Hoses

**Routing:** Plan the path of the hose carefully. Avoid sharp bends and twists. The hose should not rub against other parts or get too close to hot surfaces

**Fabrication:** Please have the hoses made professionally.

**Installation:** Make sure it's not stretched, twisted, or compressed. Secure it with clamps.

For more detailed information on hose routing, fabrication, installation please refer to ISO 17165-2:2018

### **3.6 SEL-Bus system**

Make sure fuses are installed as recommended for marine installations. Connect all SEL-Bus connectors making sure that there is a backbone ending with terminator resistors in each end.

The Central controller has inputs for five pairs of pushbuttons. Additional pairs of pushbuttons need to be connected to SEL-Bus via Pushbutton converters.

### **3.7 PSU**

Install PSU:s according to 597-275 Power supply and SEL-Bus system, section 2

### **3.8 MCU**

Install MCU:s according to 597-275 Power supply and SEL-Bus system, section 2

### **3.9 Central Controller**

Install the Central Controller according to 597-999 Central Control Unit

### **3.10 Pushbutton converter**

Install the Pushbutton converter(s) according to 597-275 Power supply and SEL-Bus system, section 2

### 3.11 Valve controller

The valve controller shall be placed inside the boat. It is resistant to marine environment, but not waterproof.

The LED lights and the user input button need to be visible and accessible.

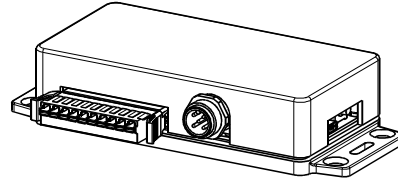

#### Installation

Connect to 12 or 24V power

1. INPUT + FUSE 5A (Red wire)
2. INPUT- (Black wire)

Cable type:

1mm<sup>2</sup> multi-stranded.  
Minimum 70 deg temperature resistant

H05V-K 1,0 EN50575:2014

Connect to SEL-Bus

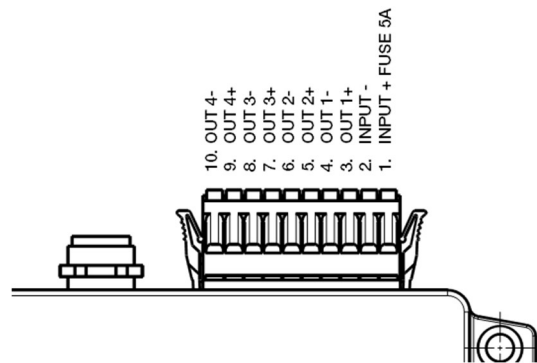

#### Connectors for valve coils

550-192 VALVE COIL CONNECTOR 12V

550-186 VALVE COIL CONNECTOR 24V

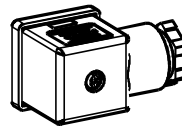

Connecting outputs from valve controller :  
(+) power supply (brown wire) to terminal 1

(-) power return (blue wire) to terminal 2

Cable type:

1mm<sup>2</sup> multi-stranded.

Minimum 70 deg temperature resistant

Example:

H05V-K 1,0 EN50575:2014

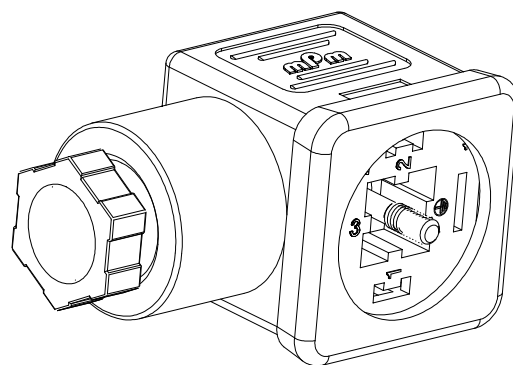

Matching a SEL-Bus control button to its valve coil

Disconnect the valve coils from the valves so that no unwanted hydraulic action is triggered by mistake during the configuration stage

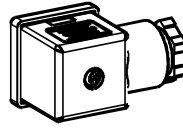

Check that "status" LED is green

Press "USER BUTTON" more than 2 seconds

Status LED1 will light up blue.  
Out1 is activated

By pushing "USER BUTTON" again status light 2 is lit up,  
and out2 is activated.

"STATUS LED":  
For installation / troubleshooting.  
Colours: Red, Yellow, Violet, Blue, Dark

"POWER PRESENT":  
Green = Power on, Dark = Power off

"STATUS OUT 1-4":  
Violet = programming mode  
Blue= Output active, normal operation  
Dark: Output not active

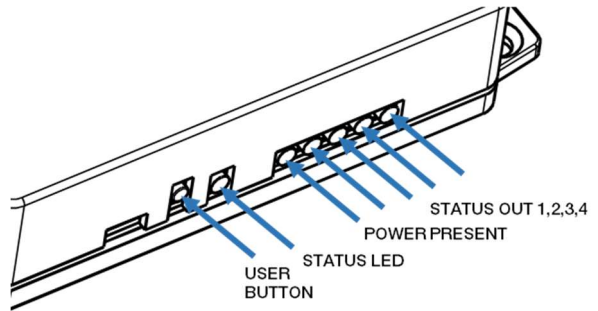

# 4 Spare parts

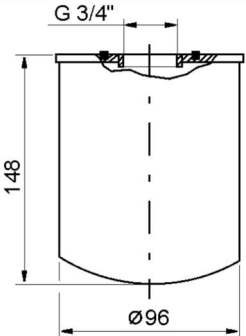
Part No.		
<p>550-135</p>	<p>OIL FILTER, SPIN-ON, FOR</p> <p>550-134-01 550-134-02 550-134-03</p> <p>Micro-fibre glass, degree of filtration 10 µm</p> <p>Manufacturer code: IKRON, HE K45-20.135-AS-FG 010</p>	

## 5 Disposal

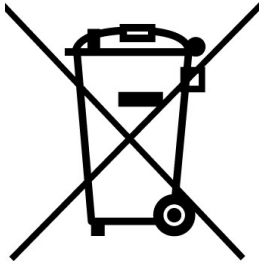

The crossed out wheeled bin symbol on the product means that used electrical and electronic equipment (WEEE) should not be mixed with general household waste. For proper treatment, recovery and recycling, please take this product(s) to designated collection points where it will be accepted free of charge. Alternatively, in some countries, you may be able to return your products to your local retailer upon purchase of an equivalent new product.

Disposing of this product correctly will help save valuable resources and prevent any potential negative effects on human health and the environment, which could otherwise arise from inappropriate waste handling.

Please contact your local authority for further details of your nearest designated collection point.

## 6 Warranty

Seldén Mast AB guarantees the HPS system for 2 years. The guarantee covers faults arising from defective design, materials or workmanship.

The guarantee is only valid if the product is assembled, operated and maintained in accordance with this manual and is not subjected to loads in excess of those indicated in the brochure and on the Seldén website.

Complete shipment and warranty conditions are to be found on the Seldén website [www.seldenmast.com](http://www.seldenmast.com). See Resources/Partners information/General information/General conditions of sale (595-546-E).

If the system is repaired or modified by anyone other than Seldén Mast AB or one of our authorized dealers, the guarantee ceases to be valid.

Seldén Mast AB reserves the right to alter the content and design without warning.