

spinlock

BE ADVENTURE-PROOF



RIG-SENSE PRO

Certified



WWW.SPINLOCK.CO.UK

For technical advice and support please email prosupport@spinlock.co.uk.

For warranty and liability, see www.spinlock.co.uk/warranty.

Spinlock Ltd, Birmingham Road, Cowes, Isle of Wight, PO31 7BH, UK.



CONTENTS

1	Policies and Terms of use
2	Quick Start Guide
3	Notes
4	Product Specification
4	Package Contents
4	Safety Precautions
5	Device Hardware Overview
6	Charging
6	Travelling
6	Power Off/On
6	User Controls
6-9	Software Instructions
7	Pages
7-8	Cable
9	Tension
9	Settings
10	Adjusting Deflector Position
10	Securing to Cable
11	Measurement Practices
11	Calibration and Accuracy
11	Using the Gauge Check Tool
12	Using with Spinlock apps
12	Load Sense App (IOS & Android)
12	Rig Sense App (IOS & Android)
13	Managing your Rig-Sense Pro
13	Troubleshooting Info and FAQ
14	Glossary of terms
15-16	Gauge Check Log
17-20	Notes

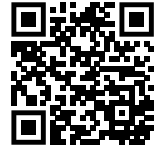
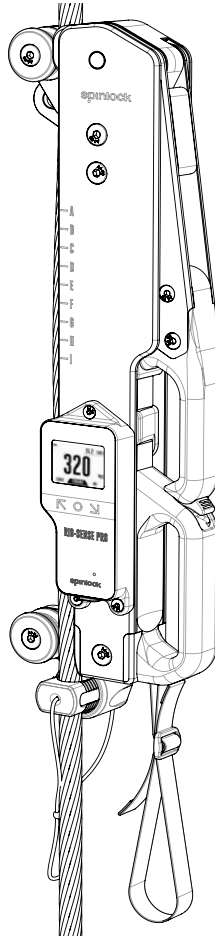

Use QR Code to view this document and videos online.



Load-Sense Mobile App

POLICIES AND TERMS OF USE

The Rig-Sense Pro is intended for use as a measurement and assistance tool only. The device must not be used as a sole safety device or relied upon to prevent injury, damage, or failure. Users are responsible for ensuring correct installation, operation, and interpretation of measurements.

Warranty

This product is covered by a limited warranty for a period of up to two years from the original date of purchase. The manufacturer shall not be held liable for any damage, injury, or loss arising from misuse, improper installation, unauthorised modification, or operation of the product outside its intended purpose.

Any attempt to open, alter, or repair the device, or the use of non-approved accessories or components, may render this warranty void.

Normal wear and tear, including but not limited to battery degradation over time, is not considered a manufacturing defect and is therefore excluded from warranty coverage.

At the end of its service life, the device must be disposed of in accordance with applicable local regulations governing electronic waste and recycling.

For full warranty terms and conditions, please visit www.spinlock.co.uk/warranty

RIG-SENSE PRO - QUICK START GUIDE

spinlock

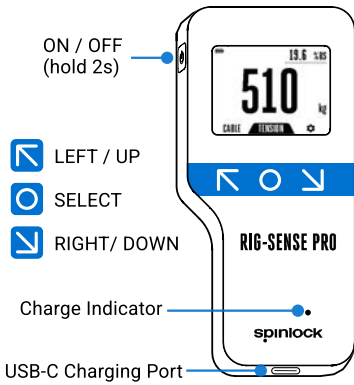

Rig-Sense Pro measures real-time tension of a wide range of cables and rods, and connects to Spinlock's **Load-Sense** App for remote operation and logging.

Navigate the menu system using the touchscreen and buttons.

Operation:

- Select your cable type and diameter from the "CABLE" menu
- Slide the Deflector to the indicated "A-1" Position
- Gently clamp the Rig-Sense Pro onto the cable/rod and ensure the handle lock has engaged to start reading tension.

Settings menu for device info and user preference adjustment: Units, Warning Limit, Brightness, Screen Timeout, and Touch Screen.

Use Gauge Check mode with supplied Check Tool to provide instant reassurance the Rig-Sense Pro is functioning correctly.

Built-in rechargeable LiPo battery gives up to 15hrs life. USB-C cable provided for fast charging in 4hrs.

PAGES

CABLE

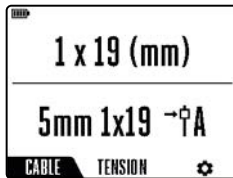

TENSION

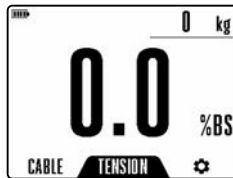

SETTINGS

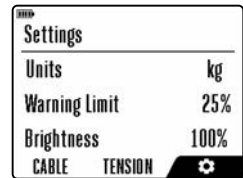

QUICK START PROCESS

Selecting Cable Type

Attaching to Cable

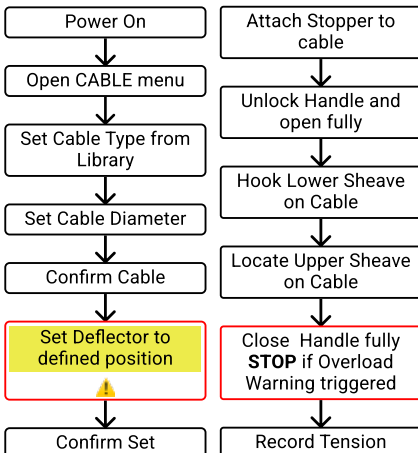

⚠ Deflector must match letter on the screen

WARNING:

Each cable has a specific A-1 Deflector position. **DO NOT** clamp the device onto a cable unless the Deflector is in the correct position, as this can cause significant **damage** to both the cable and device.

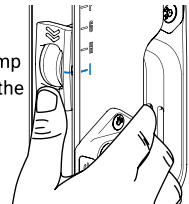

OVERLOAD WARNING:

Screen will appear if a **dangerous** load is applied. Potential **damage** could be caused to the device if not removed. Will not disappear until load is significantly reduced or taken off.



WARNING: Before long-term storage, ensure the battery is close to full charge. Store the device in a cool, dry location.



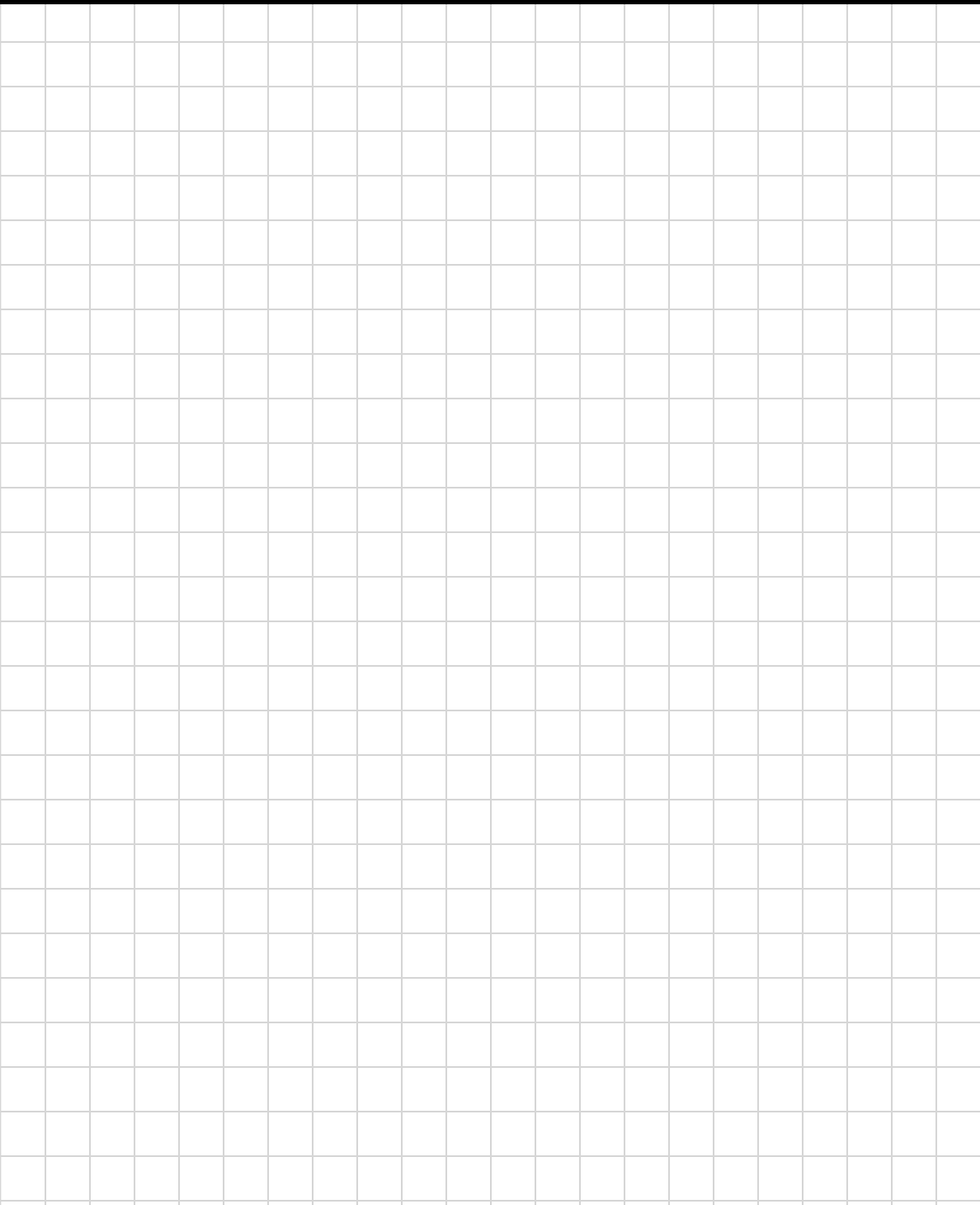

PRODUCT SPECIFICATION

Product Code	RGS-PRO/0520	Display	2.0" Touch enabled LCD
Cable Range	Cable: $\varnothing 5$ to 20 mm Rod: -6 ($\varnothing 5.0\text{mm}$) to -60 ($\varnothing 16.8\text{mm}$)	Battery Type	3.7V LiPo 2000 mAh
Accuracy	+/-1% of Cable Breaking Strength	Battery Life	Up to 15hrs
Max. Tension	8000 kg	Charging	USB-C - Full in 4hrs
Device size	500 x 50 x 161 mm	Storage	Ensure dry and clean and store in case provided.
Package size	625 x 360 x 110 mm		
Device Weight	3.2 Kg		
Package Weight	5.8 Kg		

PACKAGE CONTENTS:

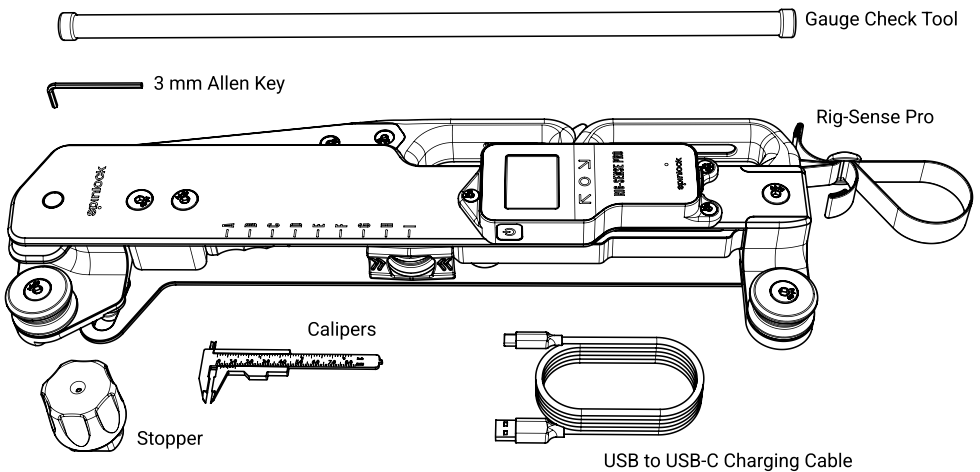

SAFETY PRECAUTIONS

- Read all instructions before using the Rig-Sense Pro.
- Use the device only for its intended purpose.
- Keep out of reach from children
- Do not expose the device to extreme temperatures, direct sunlight for prolonged periods, or open flames.
- Do not drop, crush, or subject the device to strong impacts.
- Do not attempt to open, modify, or repair the device. There are no user-serviceable parts inside.
- The device contains an integrated rechargeable lithium-ion battery. Improper use may result in damage, overheating, or reduced battery life.
- Stop using the device immediately if it becomes excessively hot, damaged, or behaves unexpectedly.
- Device is water-resistant but should not be left submerged in water.

DEVICE HARDWARE OVERVIEW

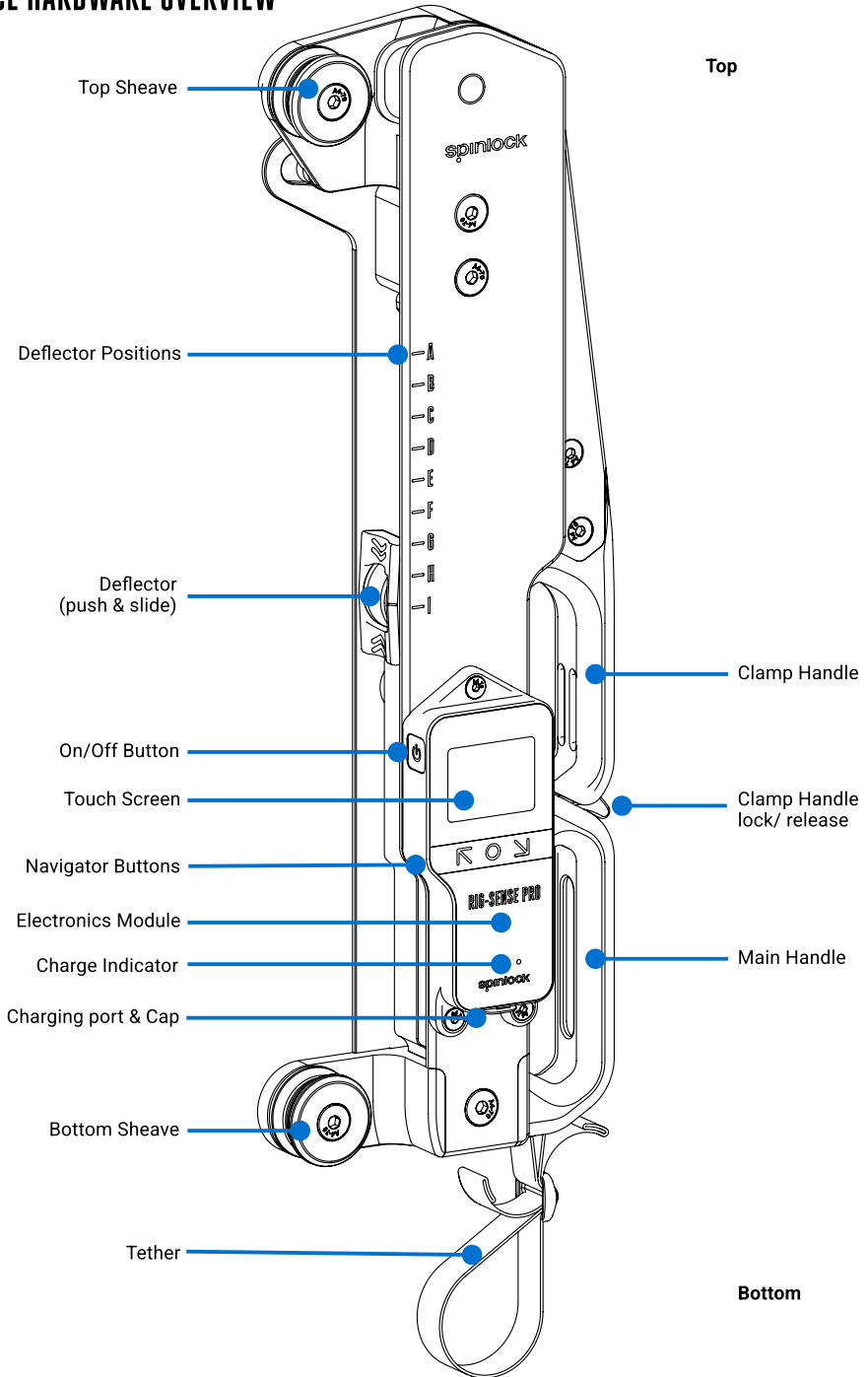

CHARGING

- Rig-Sense Pro is charged using a USB-C (cable provided).
- Open the Charge Port Flap and insert the USB-C cable, the charge indicator light will appear red when charging and green when fully charged. A full charge will power the device for up to 15 hours.
- Full charge takes approximately 4 hours.
- Device can be used while charging, however this will increase charging time and increase the risk of water damage.
- Close the Charge Port Flap after charging to prevent water and dust ingress.

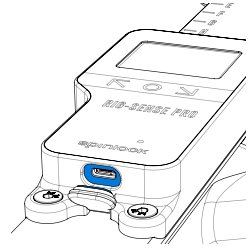

TRAVELLING

- Rig-Sense Pro contains an integrated lithium battery housed within the screen and electronics module, this may be required to be removed whilst travelling.
- If required for air travel or shipping, the screen and electrical unit (including the battery) can be removed from the device by unscrewing the three highlighted retaining bolts with the Allen key provided. Once removed, the electronics module may be transported separately in accordance with airline or carrier requirements for lithium batteries.
- Reinstallation is achieved by refitting the module and securely tightening the three bolts. Ensure the unit is correctly seated before use.
- Note: Electronics module removal should only be carried out when necessary and with the device powered off.

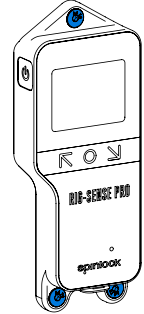

POWER ON/OFF

- To power on, hold down the power button on the side of the Display until the 'Spinlock' start-up screen appears.
- To power off, hold down the power button until screen turns off.
- If Screen Timeout is activated, the Screen will automatically dim after the set period of inactivity to help preserve battery life. Press any button or tap the screen to wake it.
- Ensure the device is correctly powered off after use to prevent battery degradation.

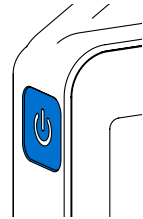

USER CONTROLS

Full control of the Rig-Sense Pro menu system is possible through both the **Touchscreen** and physical **Buttons** located below the display.

Touchscreen

- Tap page tabs to navigate between pages
- Scroll through menus by tapping above or below the selected item
- Tap selected item to confirm
- Touchscreen can be enabled/disabled in SETTINGS. (Water on the screen may cause the Touchscreen to respond incorrectly)

Buttons:

Three physical buttons are located below the display

 LEFT / UP

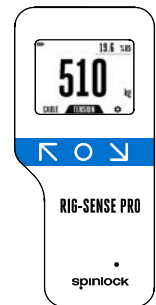

 SELECT/CONFIRM

 RIGHT/ DOWN



PAGES

Device has 3 main pages CABLE, TENSION and SETTINGS (⚙️).

Use  and  to navigate between menus and  to enter each one.

CABLE

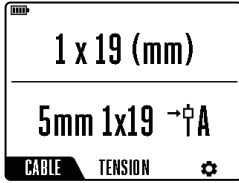

TENSION



SETTINGS



CABLE

Battery Indicator 

Cable Diameter and construction 

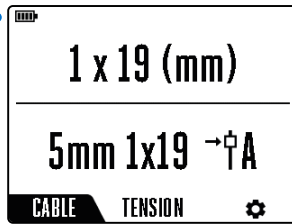



Cable Name

Deflector Position

Current Page

 Enter the page

   Navigate and Select

< Back	Returns to CABLE page and selects the last selected cable
Type	Choose cable type from Library or Favourites, or select Gauge Check Tool
Diameter	Choose from the diameters available for the selected cable type

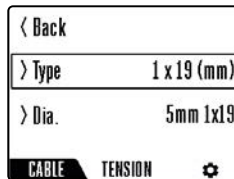

Back to Cable Page

Select Cable type

Select Diameter

Change Page

CABLE > TYPE

Favourites	Returns to cable page and selects the last selected cable
Library	Choose from types of cables in Library or select your Favourites pre-saved cables.
Gauge Check	Use the Gauge Check Tool to check the Rig-Sense Pro is functioning correctly

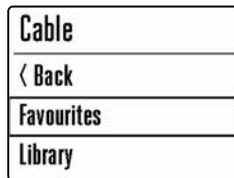

Select from favourites

Select from Library

CABLE > TYPE > LIBRARY

< Back	Returns to cable type selection page and defaults to the last selected cable
Type	Choose from types of cables

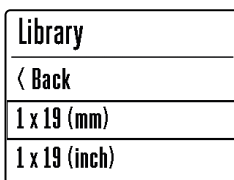

Returns to cable selection page

Select cable type

CABLE › TYPE › FAVOURITES

< Back	Returns to cable selection page and defaults to the last selected cable
Type	Choose from types of cables previously saved to favourites.

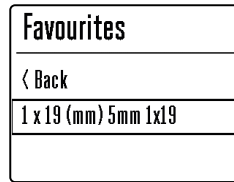

- Returns to cable selection page
- Select favourite type and diameter

CABLE › DIAMETER

< Back	Returns to cable selection page and defaults to the last selected cable
Diameter	Choose from available diameters for cable type

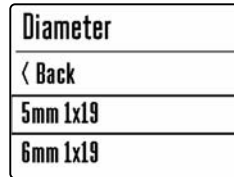

- Returns to cable selection page
- Select Diameter

CABLE › DIAMETER/ FAVOURITES › SELECTION CONFIRMATION

Navigate and Select

< Back	Returns to diameter selection page
Set	Confirms the cable selection and opens the deflector confirmation screen
☆ ★	★ currently in favourites ☆ not a favourite

After selecting a diameter or favourite, a confirmation screen is displayed showing the selected cable type and diameter.

Select the Star icon to add to or remove from favourites. A star will appear next to cables saved as favourites.

A cable and a diameter must be selected to SET the cable or to save/remove it from favourites.

Always verify the physical cable diameter matches the selected diameter on screen.

IMPORTANT

ALWAYS check the diameter of the cable with the callipers provided before attaching the Rig-Sense Pro. Incorrect cable identification may cause significant damage to both the Cable and Rig-Sense Pro, and will output invalid tension readings.

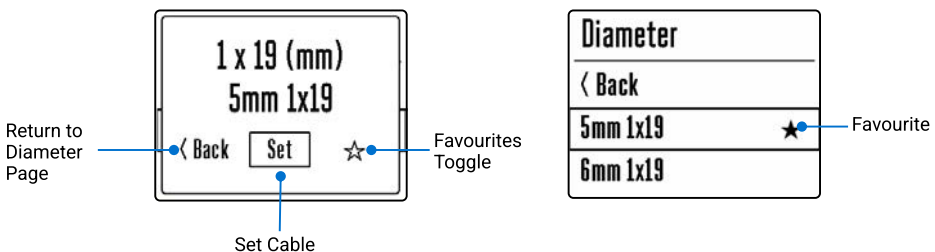

CABLE › DIAMETER/ FAVOURITES › DEFLECTOR CONFIRMATION

Deflector confirmation screen shows the correct manually set position for the selected cable. Set the Deflector to the displayed letter before proceeding.

Always verify the Deflector is manually set to correspond with the letter displayed on the screen.

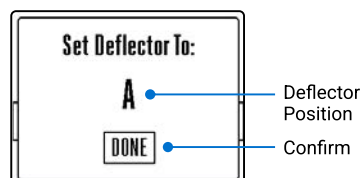

- Deflector Position
- Confirm

TENSION

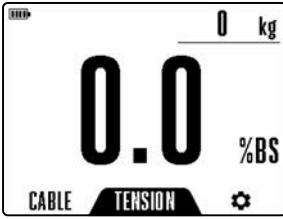

- Strain
- % Breaking Strain
- Current Page

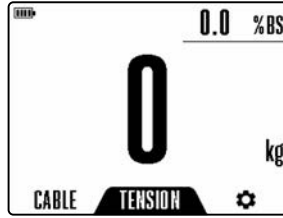

- % Breaking Strain
- Strain
- Current Page

To switch view between Tension and % Breaking Strain

Tension	Load on the Cable
%BS	Load as a percentage of the cable's breaking strain

WARNING: Screen will appear red as shown and warning buzzer will sound if % breaking strain exceeds warning %



SETTINGS

Setting Type

- Exit Settings
- Current Setting Selection
- Current Page

Enter the page

Navigate and Select

Units	Strain units: Metric (kg) or Imperial (lbs) (Diameter units are independent)
Warning Limit	Set %BS above which warning sounds and TENSION page appears red
Brightness	Device Screen Brightness
Screen Timeout	Screen dims after period of inactivity, click any button or tap screen to wake
Touch Screen	Turns the ability to control device from screen on and off
About	Shows the Serial Number and Firmware version for the device

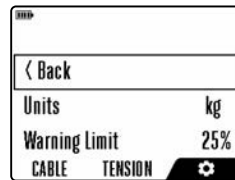

- Save Settings and Exit

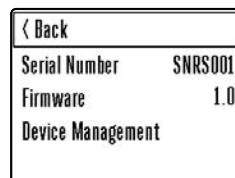

- Serial Number
- Firmware Version Update Page

All Settings and Favourites are stored on the Device and will remain in place even if powered off.

ADJUSTING DEFLECTOR POSITION

Deflector **MUST** be set to the position defined by the device **BEFORE** securing to the cable.

1. Once cable is set the screen will display the required Deflector position A-I.
2. Press on the chevron arrows and slide the deflector to align with the corresponding position letter
3. Once in correct position confirm on screen

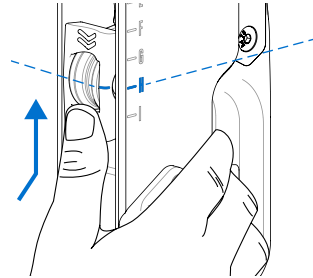
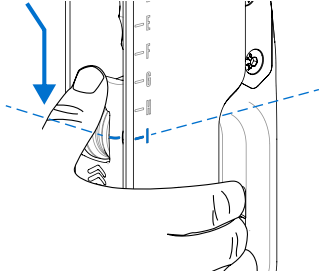

SECURING TO CABLE

1. Ensure the correct cable is selected and the Deflector is positioned correctly.
2. A stopper is supplied for use if there is insufficient friction on the cable to support the device.
 - Fit the stopper to the cable below the intended device position:
 - a. Fully unscrew the stopper
 - b. Place it around the cable
 - c. Screw tight until secure
3. Pick up the device and push the clamp handle lock down to release the clamp handle, as shown.
4. Fully open the clamp handle.
5. Route the cable around the bottom sheave.
6. Route the cable around the top sheave.
7. Slowly close the clamp handle until the clamp lock clicks, confirming the handle is locked and the device is securely attached.

A tether is provided to secure the device during use. This can be attached to a suitable part of the boat or to the user.

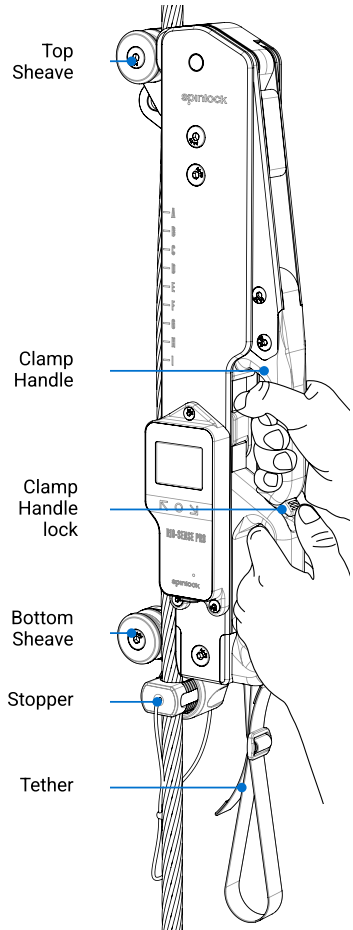
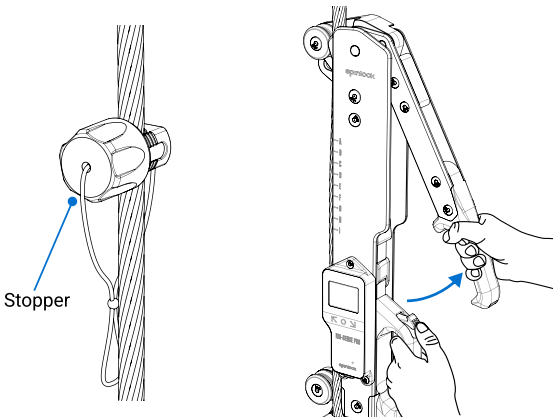

MEASUREMENT PRACTICES

To achieve the most accurate and repeatable results with Rig-Sense Pro, follow the guidelines below.

- **Positioning**
Ensure the device is attached at least 1.5m away from any terminations, fittings, knots, splices, or hardware. Measuring too close to a termination can affect localised stiffness and lead to inaccurate readings.
- **Orientation Averaging**
At each measurement position, take readings in two different orientations (for example, rotated 180° around the cable). Average the results to minimise the effects of cable construction, lay, or local asymmetry.
- **Repeat Measurements**
Take multiple readings at the same position and compare the results. Consistent values indicate a reliable measurement, while large variations suggest repositioning or repeating the process.
- **Stable Conditions**
Ensure the cable is under steady load during measurement. Avoid taking readings while the load is changing, as this may affect accuracy.
- **Cable Condition**
Check that the section of cable being measured is clean and free from twists, damage, or surface contamination, as these can influence results.

Following these practices will improve measurement accuracy and ensure consistent, reliable data across different rigs and setups.

CALIBRATION AND ACCURACY

Rig-Sense Pro is supplied with a pre-loaded range of cable settings.

The cable settings have been calibrated using a Rig-Sense Pro Reference Device.

Each Rig-Sense-Pro is calibrated to match the output of the Rig Sense Pro Reference Device using the Gauge Check Tool. This is an effective method to measurement accuracy of +/-1% of the cable Breaking Strength which should be sufficient for most applications (equivalent to +/-4% of 25% BS).

HOW TO ADD A NEW CABLE, OR UPDATE THE CABLE LIBRARY TO THE LATEST LIST?

Additional cable calibrations can be added when arranged with Spinlock and will require the supply of a 4.1m length of cable with standard rigging eyes at each end. There will be a charge to calibrate the cable.

New Cables may be available in the Library with updates (refer to 'Managing your Rig-Sense Pro' on page 13).

USING THE GAUGE CHECK TOOL

The Gauge Check Tool is provided with every Rig-Sense Pro. The Gauge Check Tool should be used regularly to confirm the device is functioning correctly. It is recommended to record results in the Gauge Check Log (Page 14).

1. Check the tool is straight by rolling on a flat surface.
2. Select Gauge Check in the Cable Menu - Select 'Gauge Check'.
3. Adjust Deflector position to the letter displayed.
4. The scale should now read near zero and the screen appears green.
If the screen appears red, the device needs checking and may require a service or re-calibration.
5. Attach the Rig-Sense Pro to the Gauge Check tool, the screen will turn red during attachment.
6. Wait for the value to stabilise, the scale should now read near 1000 and the screen appears green.
If the screen appears red, the device needs checking and may require a service or re-calibration.
7. Note all results in the Gauge Check Log (Page 14).

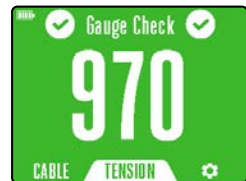

If service is required contact Spinlock at prosupport@spinlock.co.uk, include your serial number and firmware version which can be found in device settings.

USING WITH SPINLOCK APPS

LOAD-SENSE APP- CONNECTS TO RIG SENSE PRO

Load-Sense app is a mobile companion application connecting to Spinlock Load-Sense and Rig-Sense devices. It lets you connect wirelessly to one or more devices, view load measurements in real time, record data, set alarms, and export results. Available on iOS and Android devices.

DOWNLOAD

Download the app from the Apple App Store or Google Play Store by searching "Load-Sense" or using the QR code.

CONNECTING

1. Power on the Sense device.
2. Open the Load-Sense app.
3. Enable connection when prompted.
The app will automatically scan for nearby Sense devices.
4. Select your device from the list to connect.
Once connected, live load data will be displayed on screen.

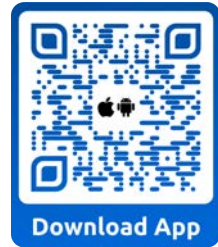

MEASUREMENT

App displays real-time load values from the connected device.
Peak load is recorded during each measurement session.
Load data can be viewed numerically and as a live graph.
Multiple Load-Sense devices can be monitored simultaneously.
Optional load alarms can be set to alert when pre-set limits are exceeded.

EXPORTING AND SHARING

Measurement sessions can be saved within the app.
Saved data can be exported for analysis or reporting.
Exported files are typically provided in CSV format, compatible with spreadsheet and analysis software.
Data can be shared directly from the app via email or file transfer.

RIG-SENSE APP- DATA LIBRARY STORE

Rig-Sense App is a simple mobile application for logging rig settings. By using the App you can store multiple settings, for multiple boats and share with the crew, training partners, clubs, classes, coaches or the rest of the world.

The intuitive and easy-to-use interface of the App makes it simple to use and understand. You can log many types of information including shroud settings, type of spinnaker and the wind range you choose. The App allows you to customise any aspect of your Tuning Guide and save it as a 'Template' and from there you can create any number of 'Files' for different boats.

All the information is stored on your Phone or Tablet.

If you are sailing a boat for the first time you can go to the class or sailmakers website to input directly to the Spinlock Rig-Sense App. You always have the information at your fingertips so you can focus sailing the boat!

Available on Android and iOS devices.



MANAGING YOUR RIG-SENSE PRO

Register your Rig-Sense Pro, download new Firmware, and receive updates and support on using your device.

Keeping your Rig-Sense Pro up to date ensures optimal performance, access to new features and the latest Rod/Cable library.

Go to www.spinlock.co.uk/sense or scan the QR code to manage your device.

You can also find the QR code within the device settings:

Settings > About > Device Management



TROUBLESHOOTING INFO AND FAQ

The device will not power on

- Ensure the device is charged. Connect it to a USB power source and charge for at least 30 minutes.
- Press and hold the power button to turn the device on.
- If the device does not respond, disconnect the charger and try again.

The device powers on but is not measuring correctly

- Ensure the device is correctly installed and attached according to the setup instructions.
- Check that all moving parts are free from obstructions.
- Restart the device and repeat the measurement.

Battery life seems shorter than expected

- Battery performance may vary depending on usage, settings, and environmental conditions.
- Frequent high-load use may reduce runtime.
- Battery capacity will naturally decrease over time.

The screen or indicator is not responding

- Power the device off and back on.
- If the issue persists, allow the device to rest and try again.

The device becomes warm during use

- Mild warmth during operation or charging is normal.
- If the device becomes excessively hot, turn it off and allow it to cool before further use.

Firmware update will not start

- Ensure wireless connectivity is enabled on your computer or Android device.
- Confirm you are using a supported browser (latest version recommended).
- Restart both the Rig-Sense Pro and the host device, then try again.
- Ensure the device battery is sufficiently charged before attempting the update.

Firmware Update fails or stops part way through

- Do not disconnect the device unless instructed.
- Wait several minutes to confirm the update has fully stopped.
- Restart the Rig-Sense Pro and repeat the update process.
- Ensure the wireless connection remains stable throughout the update.

Find further support at www.spinlock.co.uk or contact prosupport@spinlock.co.uk, include your serial number and firmware version which can be found in the 'About' section of device settings.

GLOSSARY OF TERMS

Breaking Strain (BS) - Maximum load a cable is rated to withstand before failure. Used as a reference value for strain percentage calculations.

Cable - Rope, wire, or rod that the device is clamped onto for load measurement.

Cable Diameter - Nominal thickness of the cable, selected in the device to ensure accurate load measurement.

Cable Type - Predefined cable specification (material and construction) used to determine calibration factors.

Check Tool - Known reference rod used to verify or calibrate measurement accuracy.

Confirm Set - User action that locks in the selected cable, diameter, and deflector position before measurement.

Favourite - Saved cable configuration that allows quick selection without re-entering cable details.

Firmware - The embedded software programmed into the device that stores all relevant data and controls how the system operates.

Touch Screen Display - Display used to show load, strain, menus, and system warnings.

Load - Force applied to the cable, displayed as a numeric value (kg or lbs).

Overload Warning - Safety alert displayed when measured load exceeds the configured warning threshold or safe operating range.

Sheave - Rotating component that guides the cable through the device and helps reduce friction during loading.

Deflector - Adjustable internal component that must be set to match the selected cable diameter/ specification.

Deflector Position - Lettered or indexed position of the deflector corresponding to a specific cable diameter/ specification.

Strain - Applied load expressed in kilograms.

Strain Gauge - Internal sensor that measures deformation under load and converts it into a readable value.

Units - Measurement system used by the device (metric or imperial).

Warning Limit - User-defined percentage of breaking strain at which visual/ audible warnings are triggered.

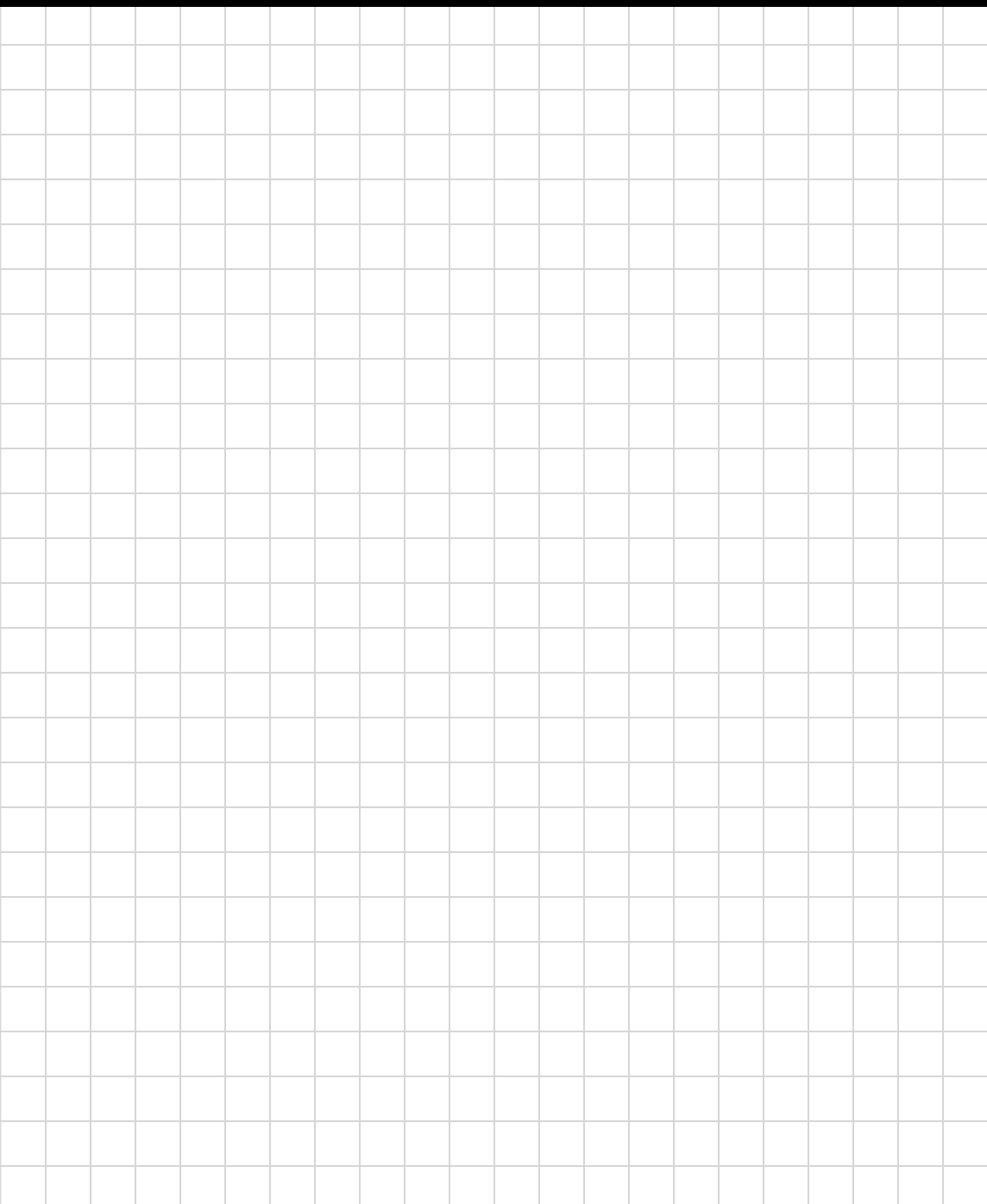



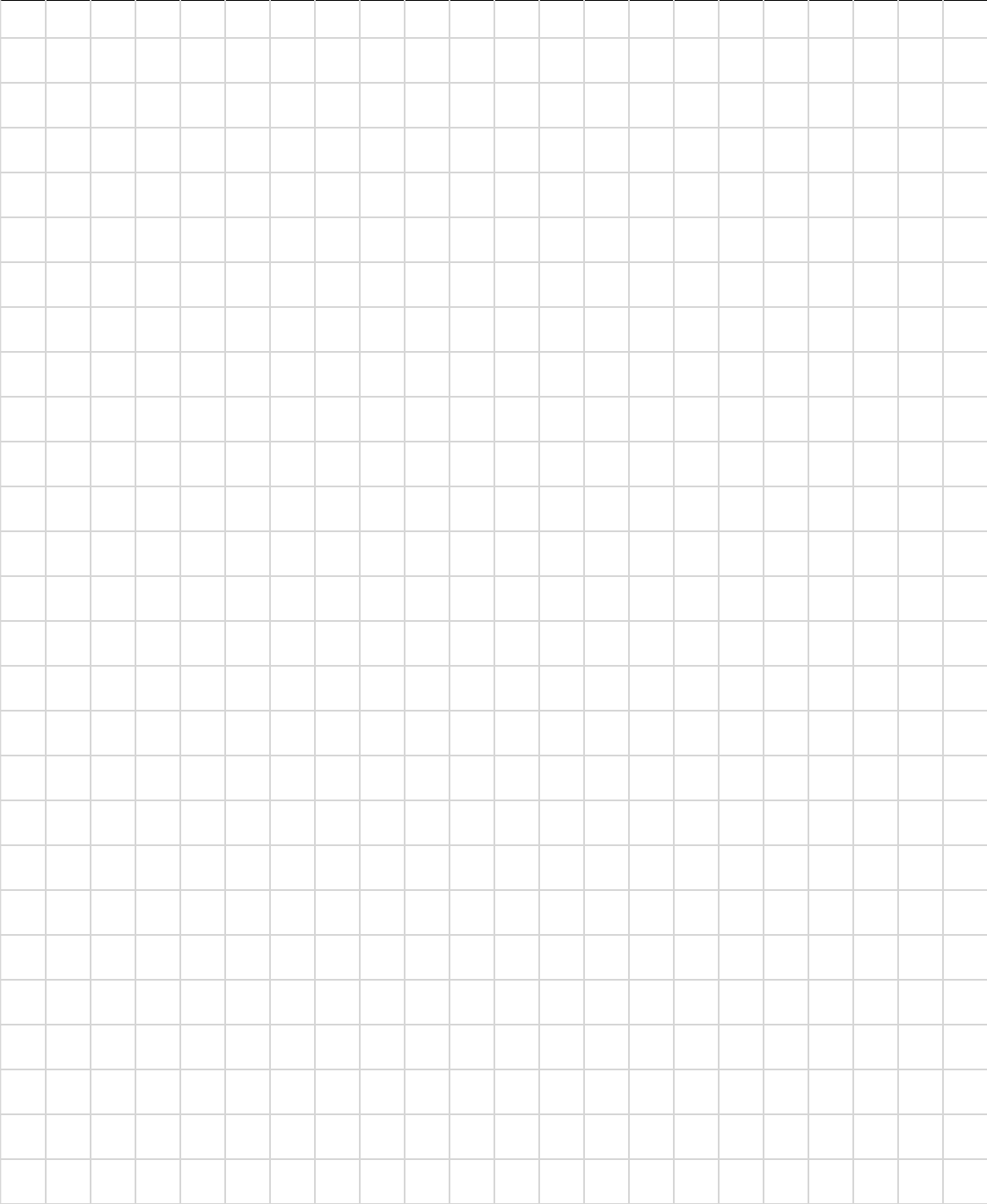

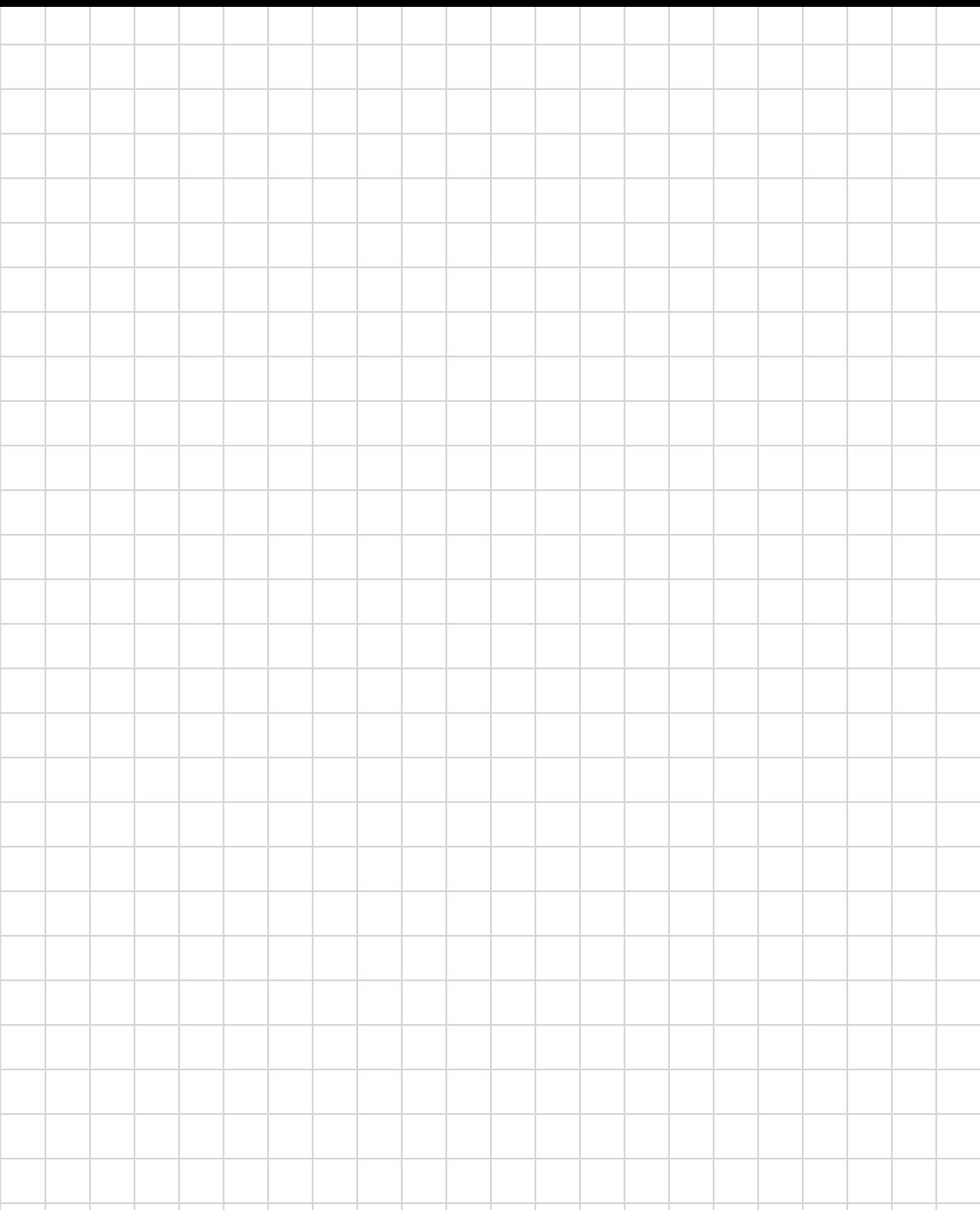

spinlock

BE ADVENTURE-PROOF

Certified



Corporation
3R1046A_3

WWW.SPINLOCK.CO.UK

For technical advice and support please email
prosupport@spinlock.co.uk.

For warranty and liability, see www.spinlock.co.uk/warranty.

Spinlock Ltd, Birmingham Road, Cowes, Isle of Wight,
PO31 7BH, UK.

