

Electric self-tailing winch

E40, E46, E52, E60 & E66

Manual for installation and operation

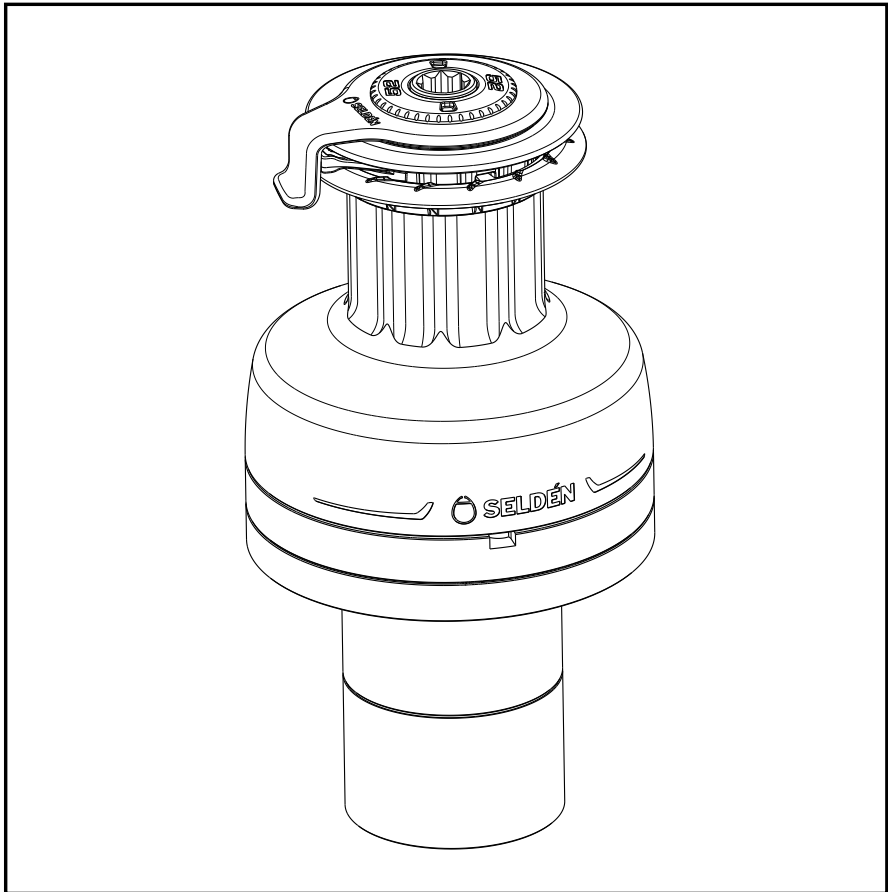

Contents

Page

1	Introduction.....	3
2	Seldén Series-E winches, E40-E66	5
	2.1 Included parts.....	5
	2.2 Optional parts	6
	2.3 System presentation	7
	2.4 Technical specification	8
3	Installation	10
	3.1 Installation preparation	10
	3.2 Winch orientation	11
	3.3 Line entry angle	12
	3.4 Fasteners	12
	3.5 Mounting the E-winch	13
	3.6 Adjusting the self-tailing arm	18
	3.7 Electric installation	18
4	Operation	19
	4.1 Electric operation	19
	4.2 Manual operation	20
5	Trouble shooting	21
6	Service and maintenance	22
	6.1 Yearly S-winch maintenance	22
	6.2 Yearly motor pack maintenance	25
	6.3 Motor pack, extended maintenance	27
7	Spare parts	28
8	Disposal	30
9	Warranty	30

1. Introduction

Congratulations on the purchase of your new electric self-tailing winch or motor pack upgrade.

This manual covers installation and operating instructions for E40, E46, E52, E60 and E66 electric self-tailing winches. The model designation for the winch is found on the top cover of the winch.

The electric self-tailing winch consists of an electric motor pack and a S-winch that sits on top of the motor pack.

The E-winch can be ordered as a complete package (winch + motor pack) or as a motor pack to upgrade an existing S-winch. S40-S66 from 2024 onwards are compatible with the motor pack upgrade.

The E-winch is powered by Seldén's 42V SEL-Bus system.

Serial number for the electric motor pack is found on the motor housing and the serial number for the winch unit is found on the winch base.

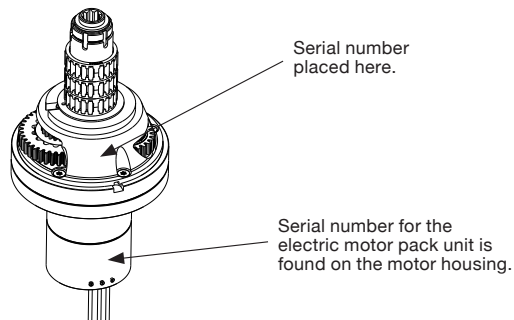

Please read the entire manual before installation/use and keep the manual available for future reference. The latest version of this manual is available at www.seldenmast.com.

Related installation manuals: 597-275 Power supply and SEL-Bus system.

Safety Precautions

Carefully pay attention to, and follow, the instructions with the following symbols:

 ATTENTION

This symbol indicates technical advice or a critical moment during the installation.

 WARNING

This symbol indicates a potentially hazardous situation. If not avoided, this could result in serious personal injury or damage to property.

Choosing the correct version of E-winch for your boat:

The key to a safe and properly working installation is correct dimensioning in relation to the boat size the products shall be used on. Seldén provides dimensioning guidelines in catalogues, leaflets and on the website. If there are any questions about selecting the right product, please consult an authorized Seldén dealer. All dealers are listed at www.seldenmast.com and divided in categories describing their competence.



The winch is designed for handling of sail and rig control lines. Mooring, towing, hoisting a person or any other type of misuse may lead to winch failure and/or serious or fatal injuries.



Exceeding the stated safe working load may lead to winch failure and/or serious or fatal injuries.



Keep body parts, hair, and clothing away from moving parts while the winch is in use. It is recommended to let only one person work with the winch at any time.



Turn off the power to the SEL-Bus system when it's not in use, to eliminate the risk of unintentional activation.





Control buttons should be placed near the winch or in such a way that the operator has complete control over the winch.



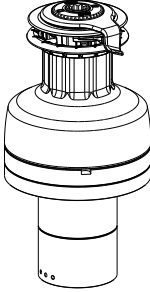
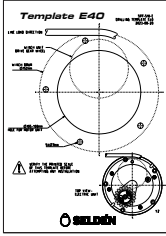

An easily accessible emergency stop should be installed to turn off the power to the winch.

2 Seldén Series-E winches, E40-E66

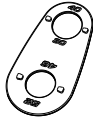
2.1 Included parts

Description		Item No.	Illustration
Seldén Series E-winch			
E40	Winch, Aluminium drum Motor pack	475-140-01 473-430-02	
E46	Winch, Aluminium drum Motor pack	475-146-01 473-530-02	
E52	Winch, Aluminium drum Motor pack	475-152-01 473-530-02	
E60	Winch, Aluminium drum Motor pack	475-160-01 473-630-02	
E66	Winch, Aluminium drum Motor pack	475-166-01 473-630-02	
Fasteners (For mounting manual S-winch to motor pack)			
E40		162-061	4x M8x35
E46		162-061	5x M8x35
E52			
E60		162-047	5x M10x40
E66			
Drilling template			
E40		597-510 597-509 not to be used!	
E46		597-511	
E52			
E60		597-512	
E66			
Manual for installation and operation. E-Winch / Motor pack S-Winch		597-490 597-489	
Winch tool		473-010	

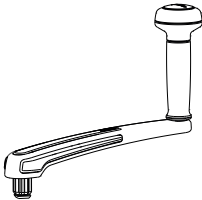
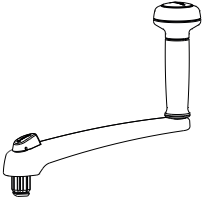
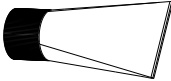
2.2 Optional parts

Description	Item No.	Illustration
10" Race GRIP winch handle	474-501-10	
8" Race GRIP winch handle	474-401-10	
10" STANDARD winch handle	474-301-10	
8" STANDARD winch handle	474-201-10	
Seldén lubrication grease	312-501	
Pawl oil (50 ml)	312-709-01	

2.3 System presentation

Power supply and SEL-Bus system

The E-winchs are used together with the Seldén Power supply and SEL-Bus system. The E-winch is connected to a motor control unit (MCU), which enables communication with the power supply unit and push buttons. The E-winch is either connected to an existing SEL-Bus system (only requiring an additional MCU, push buttons and SEL-Bus converter) or to a new installation. An emergency stop should be connected to the power supply.

Parts for the SEL-Bus system are sold separately and can be found in the order guide 597-283.

The SEL-Bus system is described in manual 597-275.

The illustration below shows an example of a typical E-winch electrical installation. The complete Power Supply and SEL-Bus system of each installation will vary and can include additional units and functions (e.g. Furlex Electric, CXe and Synchronized Main Furling).

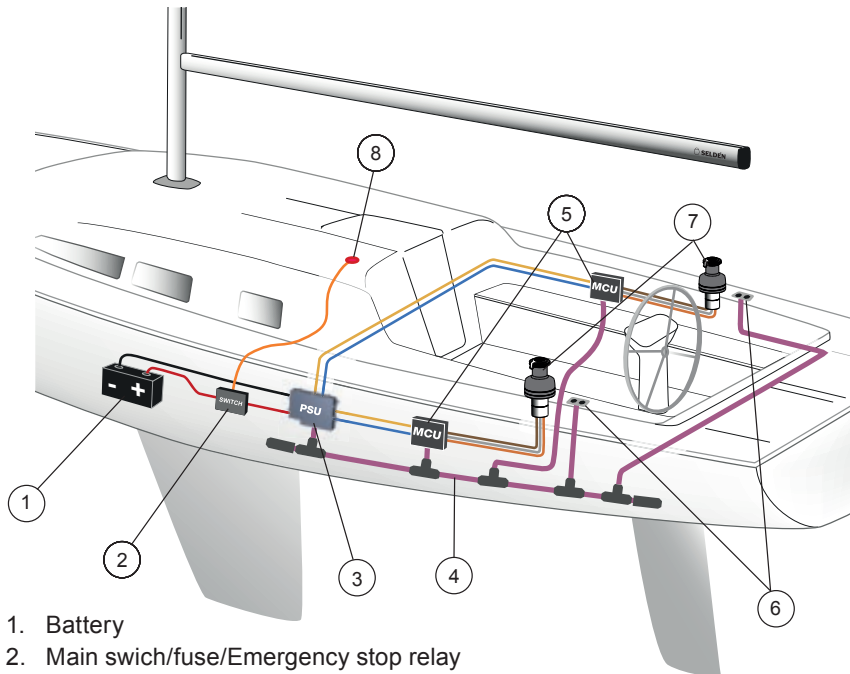

1. Battery
2. Main switch/fuse/Emergency stop relay
3. Power Supply Unit (PSU)
4. SEL-Bus backbone cables and connections
5. Motor Control Unit (MCU) (2x)
6. Push-button for electric self-tailing winch (2x)
7. Electric self-tailing winch (2x)
8. Emergency stop button

2.4 Technical specification

Main components

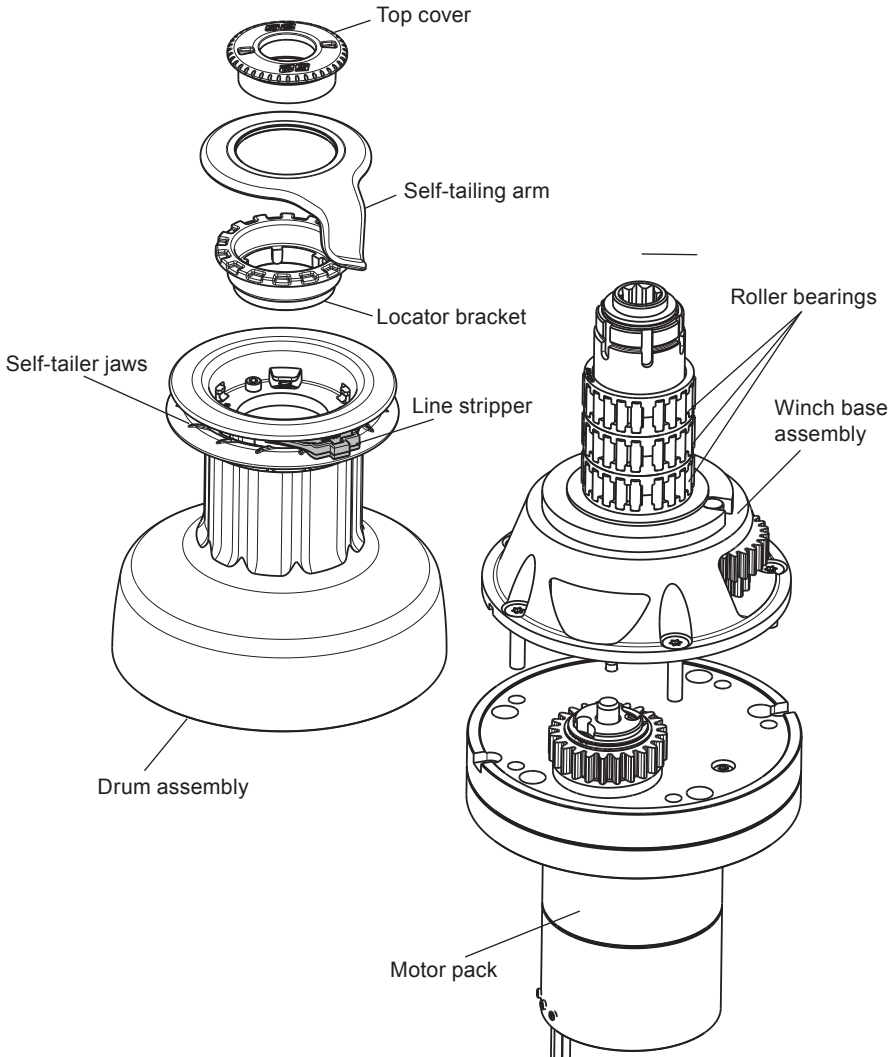

Dimensions and technical data

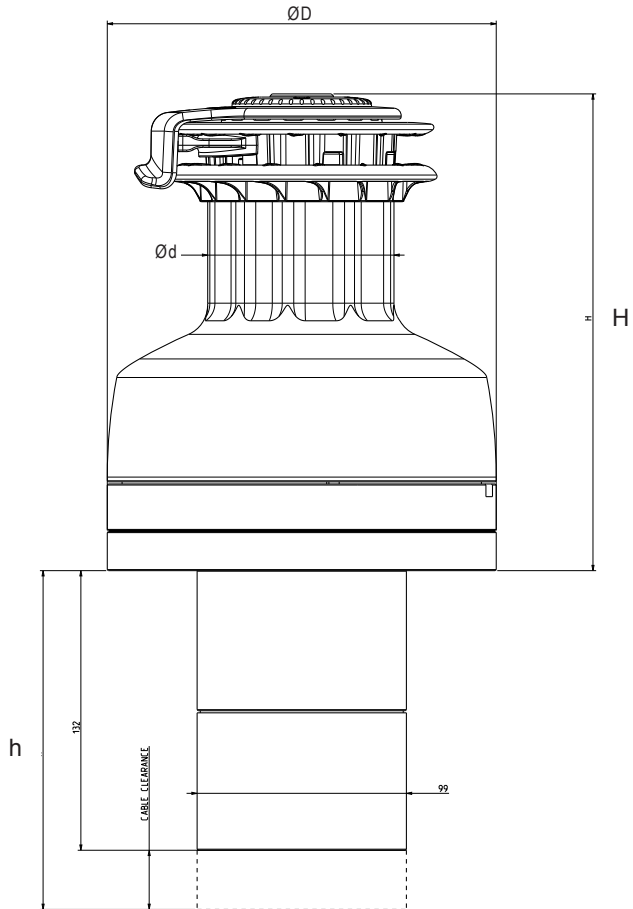

Model	Height above deck (H) (mm)	Protrusion below mounting surface (h)	Base \varnothing ($\varnothing D$) (mm)	Drum \varnothing ($\varnothing d$) (mm)	Suitable Line dimensions	Power ratio		Weight (kg)	Maximum line speed (m/min)	Safe Working Load (SWL) (kN)	Electric Cut-off load (ECL) (kN)
						High Gear	Low Gear				
E40	202	145	$\varnothing 152$	$\varnothing 75$	8-12	13:1	40:1	9,9	54	11,2	6.7
E46	226	145	$\varnothing 184$	$\varnothing 90$	8-14	13:1	46:1	13,2	40	12,9	9.7
E52	226	145	$\varnothing 184$	$\varnothing 90$	8-14	15:1	52:1	13,2	40	14,6	9.7
E60	279	145	$\varnothing 245$	$\varnothing 120$	8-16	18:1	60:1	23,2	28	16,8	14.7
E66	279	145	$\varnothing 245$	$\varnothing 120$	8-16	20:1	66:1	23,3	28	18,5	14.7



Exceeding the recommended max line dimensions may damage the self-tailing jaws and may also cause other damages and/or injury.

3 Installation



Installation of a Seldén winch must be carried out by a competent installer who has read and understood this installation manual, the purpose and function of the winch and has checked the loads, winch sizing and mounting requirements prior to installation.



Before installation, verify that installation can be carried out without damaging the interior of the boat. This includes that the full insertion depth of the winch can be obtained and that there is space for the electrical installation (PSU, MCU, cables, etc.).

Seldén Mast AB does not take responsibility for incorrect installation of a winch, insufficient reinforcement of the deck at the location of the winch, water ingress due to insufficient sealing or any damage to interior as a result of water ingress.

3.1 Installation preparation

The winch should be mounted on a flat surface. If not, any uneven surface must be compensated with shims.

Winch position relative to associated components and location regarding deck reinforcement and suitability must be checked. The winch should not be mounted on any part of deck that is laminated using a soft sandwich construction. Any reinforcement work must be carried out prior to installation.

The installer takes full responsibility to ensure these checks have been undertaken. This may require the assistance of a boat yard or marine engineers.

If the winch is mounted on a surface made from stainless steel, steel, bronze or brass, the winch base must be insulated from the mounting surface to prevent galvanic corrosion.

The electrical installation is described in the SEL-Bus manual 597-275, make sure to read and understand this before the winch installation.



The E-winch must be connected to the correct MCU for that specific winch, failing to do so may lead to damage to the boat and/or equipment and can potentially cause fatal injuries.

3.2 Winch orientation

To allow for the best performance and longevity of the winch the mounting orientation must be correct with regards to the direction of the line. The correct orientation is shown in the figure below.

If the winch has multiple uses, such as combined halyard and spinnaker trimming, the winch should be position with regards to the highest load.

Both the drilling template and the which can be used to ensure the correct orientation.

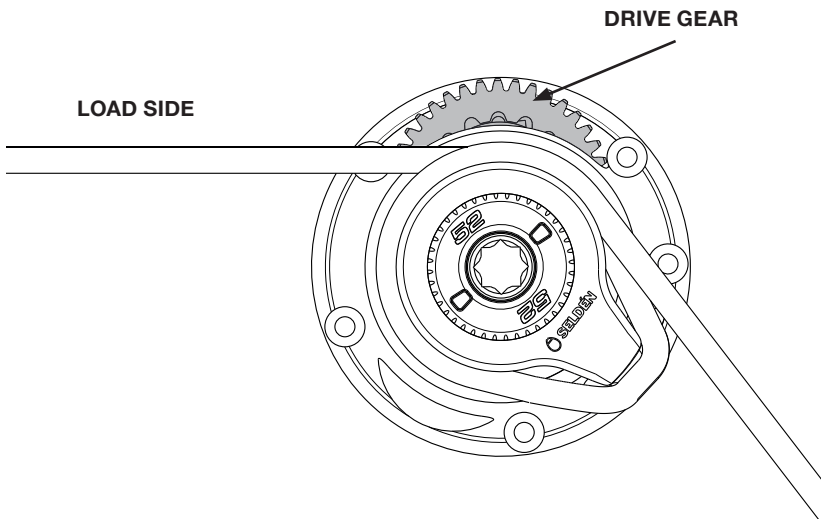

3.3 Line entry angle

To minimize the risk of override, the line should enter the winch in accordance with the picture below.

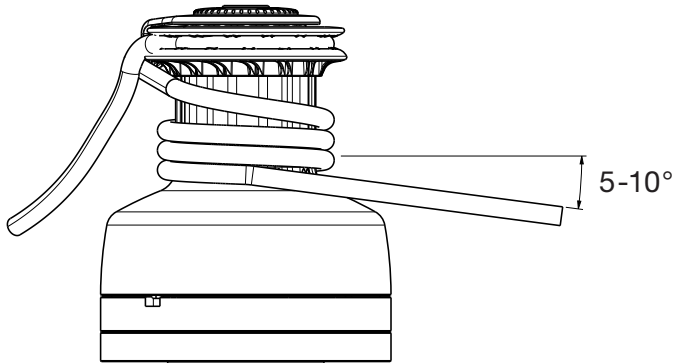

3.4 Fasteners

The winch could either be mounted by through deck screws with washers and nuts or, if the boat has purpose made metal plates laminated into the deck structure, be threaded into these.

If through deck screws are used, make sure that it's possible to fit washers and nuts below deck.

The fasteners for mounting the winch to the deck are not supplied with the winch. The installer is responsible for sourcing fasteners and ensuring they are rated for the expected loads from the winch. Any fastener should be made from marine grade stainless steel.

Fastener and drill dimensions:

Winch size	Qty of fasteners	Fastener type and dimension	Marking drill size ¹⁾	Through deck drill size	Drill size for M-thread
E40	5 pcs	Socket head M6 screws	Ø 6,5 mm	Ø 7 mm	Ø 5,0 mm
E46, E52	5 pcs	Socket head M8 screws	Ø 8,5 mm	Ø 9 mm	Ø 6,8 mm
E60, E66	5 pcs	Socket head M10 screws	Ø 10,5 mm	Ø 11 mm	Ø 8,5 mm

¹⁾ When using the template for marking, use a smaller drill.

3.5 Mounting the E-winch

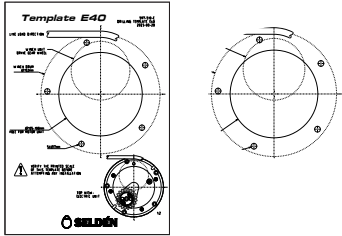
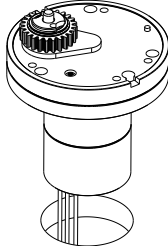
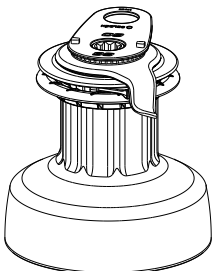
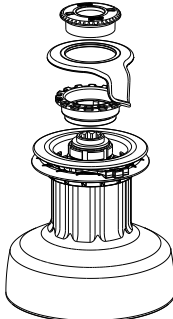
<p>1.</p> <p>Use the supplied drilling template to mark the center of the large hole.</p> <p>Drill the large hole, Seldén recommends using a \varnothing 102-105 mm hole saw to make the hole.</p>	
<p>2.</p> <p>Feed the cables and the motor pack through the center hole.</p>	
<p>3.</p> <p>Unscrew the top cover of the S-winch using the winch tool that was supplied with the winch.</p>	
<p>4.</p> <p>Remove the top cover, the self-tailing arm and the locator bracket.</p>	

5.

Remove the drum. Make sure the roller bearings remain on the winch base.

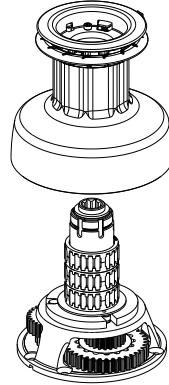

6.

Put the S-winch base on top of the motor pack.

Oriente the winch assembly according to section 3.2 *Winch orientation*.

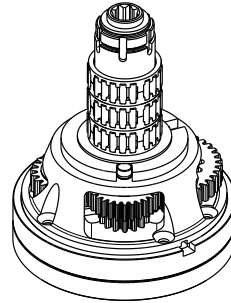

7.

Remove the winch base without changing the orientation of the motor pack.

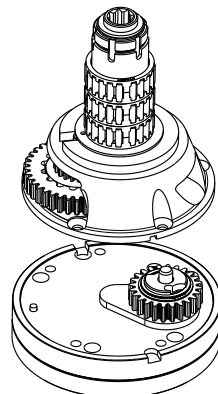

8.

Mark the fastening holes using the motor pack as a template. See table in section 3.4 *Fasteners*, for marking drill recommendations.

Remove the motor pack and drill the holes through deck according to the intended fastening method. Set table in section 3.4 *Fasteners*, for drill size recommendations.

Make a countersunk recess at the top of the holes. This is to create a better seal around the fastener.

Thread the holes if this is the chosen fastening method.

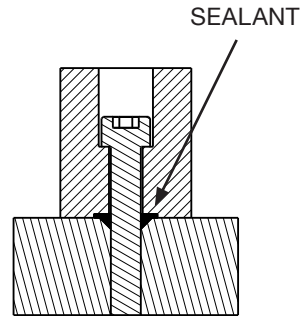

9.

Check with the motor pack and fasteners that the holes and/or threads are correctly located.

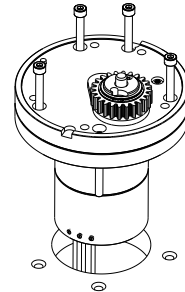

10.

Fit the fasteners to the motor pack. Seal around the fasteners and around the bottom of the motor pack surface that is in contact with the deck.

- ! Seldén recommends to not use glue as sealant. A sealing compound that does not solidify, e.g. Butyl compound, will simplify any removal of the motor pack in the future.

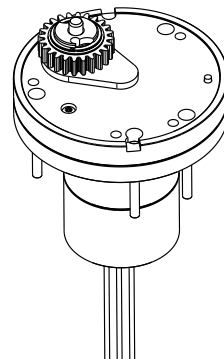

11.

Fit the motor pack to the boat with the fasteners still in position.

When using through deck screws it is recommended to tighten the nut while holding the screws stationary.

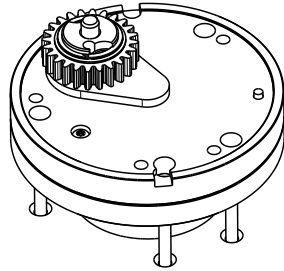

12.

Fasten the winch base to the motor pack with the supplied fasteners.

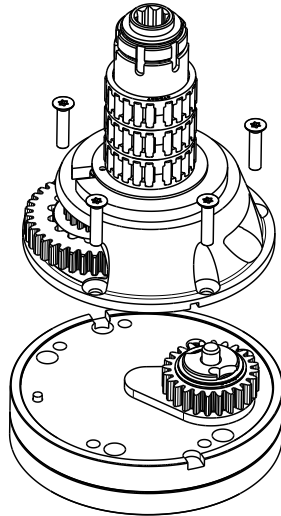

13.

Refit the drum, locator bracket and the self-tailing arm.

Make sure that the line stripper is positioned in line with and held captive by the self-tailing arm.

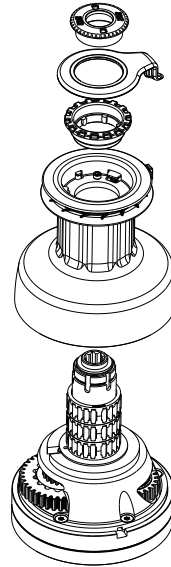

14.

Adjust the self-tailing arm to have the line exiting the self-tailing jaws in the desired direction.

Attach and tighten the top cover using the supplied winch tool.

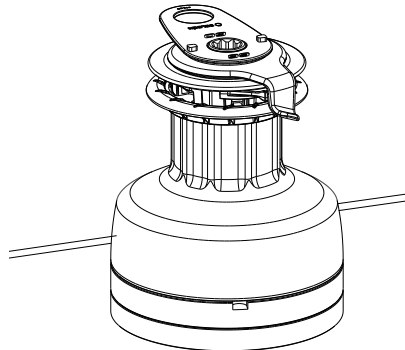

3.6 Adjusting the self-tailing arm

1.

The self-tailing arm can be adjusted to feed the line into the cockpit. To do this, unscrew the top cover and lift the self-tailing arm.

The self-tailing arm can now be rotated to allow the line to feed properly. Be sure to refit the self-tailing arm correctly in the grooves on the locator bracket.

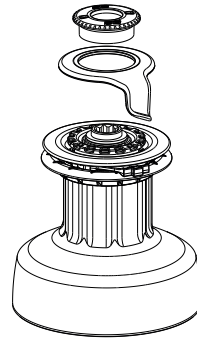

2.

Make sure that the line stripper is positioned in line with, and held captive by, the self-tailing arm before refitting the top cover.

Tighten the top cover using the supplied winch tool.

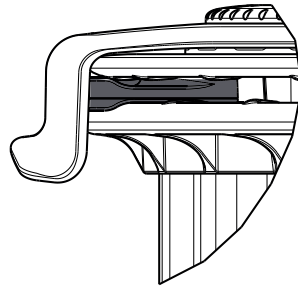

3.7 Electric installation

This section shows the connection of the winch to the MCU. For the complete electrical & SEL-Bus installation, see manual 597-275 Power supply and SEL-Bus system.

Connect the three cables from the motor pack to the winch MCU. Make sure the different colored cables are connected to the correct terminal as shown on the MCU.

If needed, the cables can be cut to length before connecting.

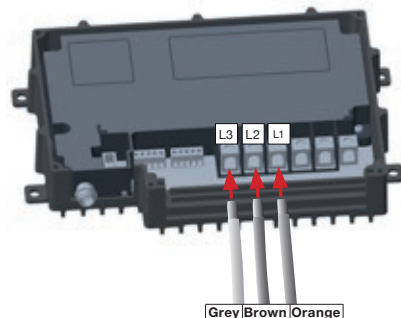

4 Operation

4.1 Electric operation

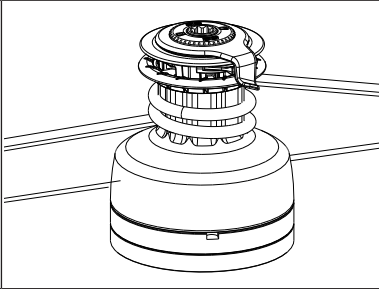
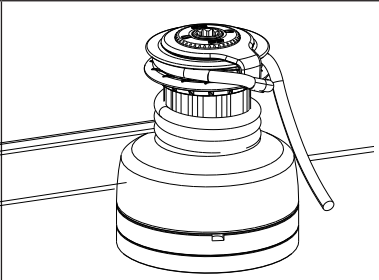
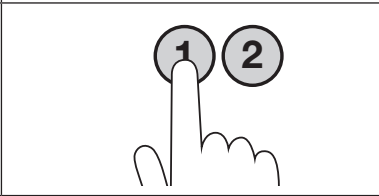
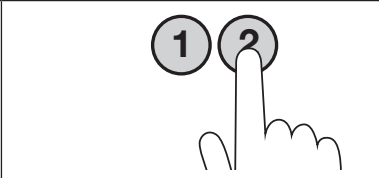
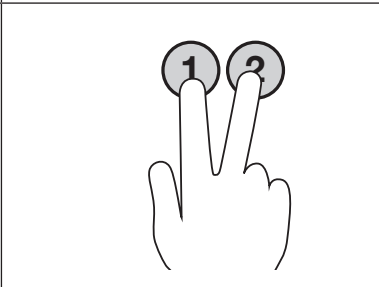
<p>1. Apply 2-3 turns on the winch drum and pull any slack in the line. Fewer or more turns may be required depending on the conditions.</p> <p> More turns on the winch drum increases the risk of override, when pulling the slack.</p>	
<p>2. Add more turns if required and then feed the line over the self-tailing arm and lock it in the self-tailing jaws.</p>	
<p>3 a. Press button “1” to engage the winch at the low-speed setting.</p>	
<p>3 b. Press button “2” to engage the intermediate-speed setting.</p>	
<p>3 c. Press both buttons “1” and “2” simultaneously or subsequently in any order to engage the high-speed setting. If pressing the buttons subsequently to engage the high-speed setting, the winch will briefly slow down before engaging the high-speed setting.</p>	

4.2 Manual operation

The electric winch may be operated manually at any time, electrically powered or not. The manually operated winch will perform with full 2-speed manual function equivalent to the corresponding S-winch.

1.

Apply 2-3 turns on the winch drum and pull any slack in the line. Fewer or more turns may be required depending on the conditions.



More turns on the winch drum increases the risk of override, when pulling the slack.

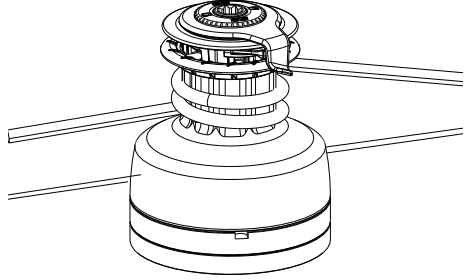

2.

Add more turns if required and then feed the line over the self-tailing arm and lock it in the self-tailing jaws.

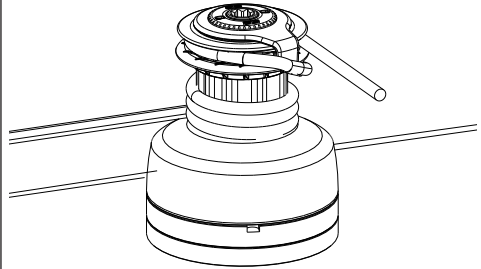

3.

Using a winch handle, trim the rest of the line until desired shape of the sail and/or tension of the sheet or halyard has been reached.

Rotating the winch handle anti-clockwise will engage the high speed gear. If more power is needed, rotating the winch handle clockwise will engage the low speed gear.

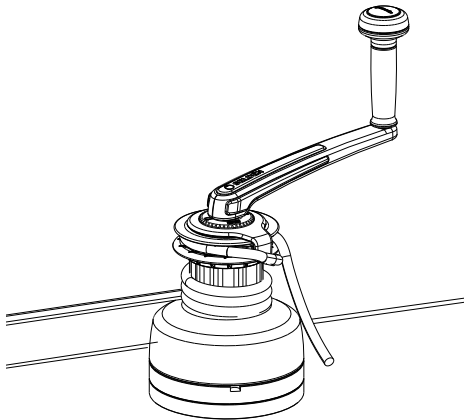

5 Trouble shooting

Information on troubleshooting the SEL-Bus system is found in the SEL-Bus manual 597-275.

Problem	Problem cause	Action
Loss of self-tailing function	1. Line not properly seated in self-tailing jaws.	1. Check line seating in self-tailing jaws.
	2. Too few turns on winch drum.	2. Add turns until self-tailing function is resumed.
	3. Incorrect line size. See table in section 2.4.	3. Change to correct line size.
The winch is not ratcheting	1. Faulty reassembly of ratchet gears.	1. Flip ratchet gears to match pawl engagement.
	2. The winch needs maintenance.	2. Perform maintenance.
Winch is not engaging when operated via pushbuttons.	1. Power is not switched on.	1. Switch on power.
	2. Emergency stop is activated.	2. Reset the emergency stop.
	3. SEL-Bus main fuse has tripped.	3. Check the fuse.
	4. SEL-Bus error.	4. Check the LED-indicators on the MCUs and PSU for fault or error codes. See SEL-Bus manual for code explanation.
	5. Network fuses.	5. Check that no fuses have tripped. Replace broken ones. See SEL-Bus manual for more information.
	6. Faulty electric installation.	1. Check network and electric cable connections.
2. Reconfigure buttons in accordance with the SEL-Bus manual.		

6 Service and maintenance

To maintain top performance and assure longevity for all parts of your self-tailing winch, it is recommended to occasionally rinse the winch with freshwater.

6.1 Yearly S-winch maintenance

The maintenance described below should be performed at least once every year, for heavily used winches (racing boats, charter boat, etc.) more frequent maintenance than once a year is recommended.

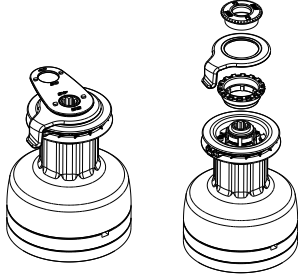
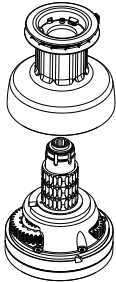
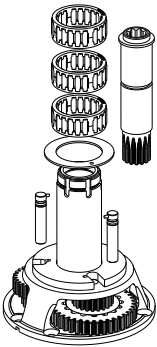
<p>1.</p> <p>Unscrew the top cover using the winch tool supplied with the winch. Remove top cover, self-tailing arm and locator bracket.</p> <p>Note the position of the self-tailing arm.</p>	 <p>The diagram illustrates the first step of maintenance. On the left, a winch is shown with a self-tailing arm attached to its top. On the right, the top cover, self-tailing arm, and locator bracket are shown being removed from the winch, with arrows indicating their upward movement.</p>
<p>2.</p> <p>Remove the drum assembly. Make sure the roller bearings remain on the winch base.</p>	 <p>The diagram shows the drum assembly being lifted off the winch base. The drum assembly consists of a top cap and a central drum. The roller bearings are shown remaining on the winch base.</p>
<p>3.</p> <p>Remove the roller bearings, drum washer and the drive shaft.</p> <p>The drive shaft has a friction lock (O-ring) which means that some extra force may be needed to pull it out. Use a winch handle if necessary.</p> <p>Remove the two gear shafts by inserting a small flatheaded screwdriver into the slot on the shaft and lifting.</p>	 <p>The diagram illustrates the removal of the roller bearings, drum washer, and drive shaft. The roller bearings are shown being lifted out of the winch base. The drum washer is shown being removed from the drum. The drive shaft is shown being pulled out of the winch base. The gear shafts are shown being lifted out of the winch base.</p>

4.

Remove the two gear assemblies.
Pay attention to the washers.

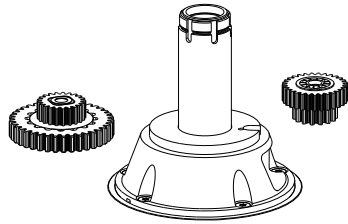

5.

Disassemble the gears and clean all parts thoroughly using white spirits. Inspect pawls and springs and replace if worn or damaged.

When clean, apply pawl oil on the pawls and apply a thin layer of grease to the gear teeth and the cylindrical surface of the small hub.

For recommended pawl oil and grease, see section 2.2 *Optional parts*.

Re-assemble the gears.

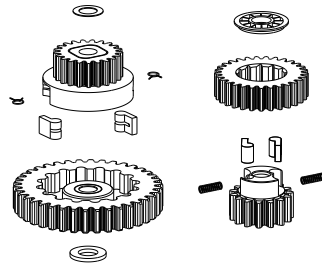

6.

Grease the small shafts. Refit the gears and shafts in the winch base.

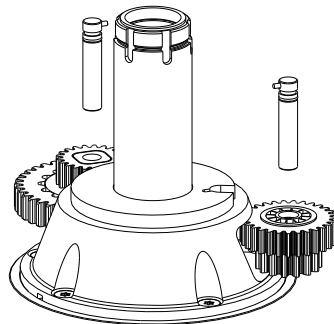

7.

Clean the gear on the inside of the drum and apply a thin layer of grease.

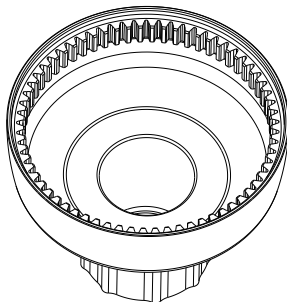

8.

Apply a thin layer of grease to the gear on the drive shaft.

Refit drum washer, roller bearings, drive shaft and drum.

Do not grease the roller bearings!

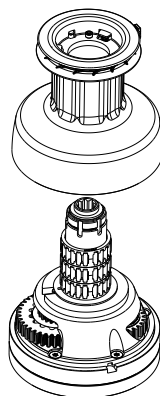

9.

Fit the locator bracket and the self-tailing arm.

Make sure that the line stripper is positioned in line with, and held captive by, the self-tailing arm before refitting the top cover.

Attach and tighten the top cover using the supplied winch tool.

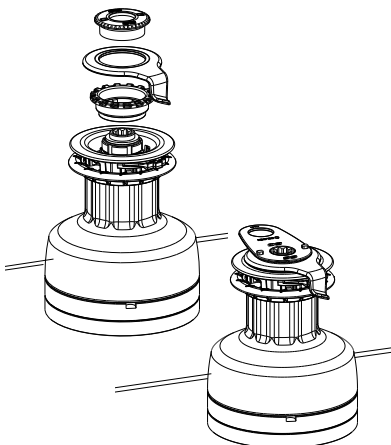

6.2 Yearly motor pack maintenance

The maintenance described below should be performed at least once every year, for heavily used winches (racing boats, charter boat, etc.) more frequent maintenance than once a year is recommended.

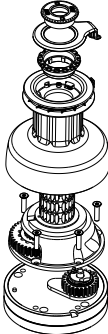
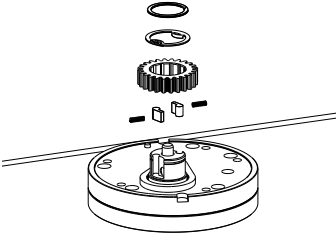
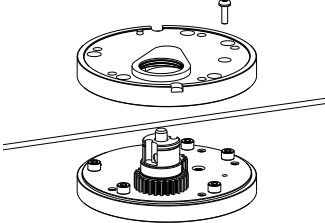
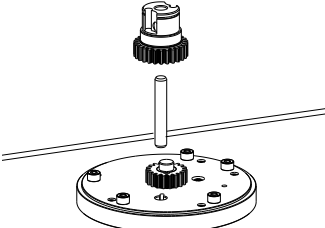
<p>1.</p> <p>Disassemble the winch according to section 6.1, steps 1-2.</p> <p>Remove the winch from the electric motor pack by removing the screws holding the winch base.</p>	
<p>2.</p> <p>Remove the locking ring, washer, and gear, followed by pawls and springs.</p> <p>Replace any worn or damaged parts.</p>	
<p>3.</p> <p>Remove the fastener holding the top plate.</p> <p>Remove the top plate carefully, a soft prying tool can be used to assist the removal.</p>	
<p>4.</p> <p>Remove ratchet hub (and shaft on E46-E66, do not remove the shaft on the E40). Clean all parts.</p> <p>Do not use any degreaser on the parts that are still contained in the base plate as this may cause damage to internal parts.</p>	

5.

Grease the shaft. Refit the ratchet hub and grease the gears generously. Refit the top plate.

Make sure that the top plate sits correctly and tighten the locking screw.

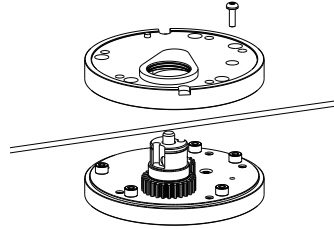

6.

Apply a thin layer of grease to the cylindrical surface of the pawl hub and to the gear teeth. Assemble the ratchet gear. Use pawl oil on the pawls, not grease!

For recommended pawl oil and grease, see section 2.2 *Optional parts*.

If the locking ring was deformed at disassembly, it must be replaced.

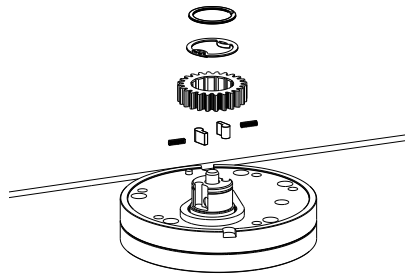

7.

Refit the winch base, tighten the screws and refit the drum.

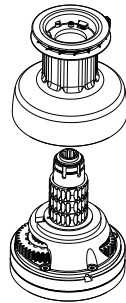

8.

Fit the locator bracket and the self-tailing arm.

Make sure that the line stripper is positioned in line with, and held captive by, the self-tailing arm before refitting the top cover.

Attach and tighten the top cover using the supplied winch tool.

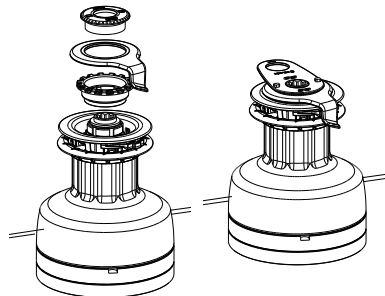

6.3 Motor pack, Extended maintenance

Seldén recommends that extended maintenance is performed every five years. The extended maintenance should only be carried out by a knowledgeable technician and is explained in the manual 597-990 Motor pack extended maintenance.



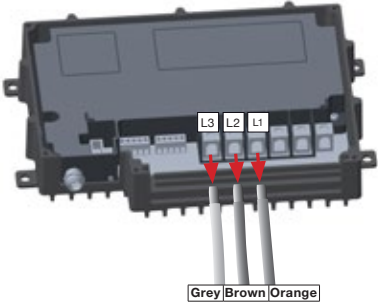
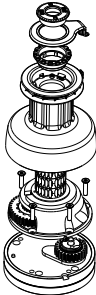
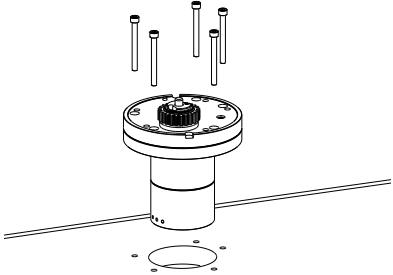

Remove and refit the motor pack

<p>1.</p> <p>Make sure all power to the SEL-Bus system has been disabled. Disconnect the motor pack cables from the winch MCU</p>	
<p>2.</p> <p>Disassemble the winch according to section 6.1, steps 1-2.</p> <p>Remove the winch from the motor pack by removing the screws holding the winch base.</p>	
<p>3.</p> <p>Remove the electric power pack from the boat.</p>	
<p>4.</p> <p>When the extended maintenance is done, the winch can be reinstalled. See section 3.5 <i>Mounting the E-winch</i>, steps 10-14.</p>	

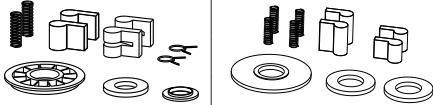
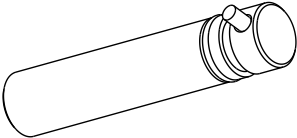
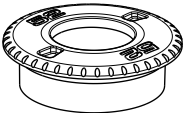
7 Spare parts

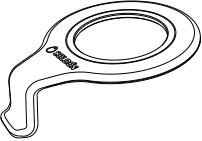
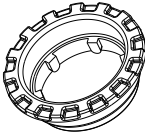
The following spare parts kits can be purchased for your Seldén winch:

Description	Art. No.		
Fastener Kit (For fitting S-winch to motor pack)			
E40	162-061-10R	4x M8x35	
E46/E52	162-061-11R	5x M8x35	
E60/66	162-047-10R	5x M10x40	
Pawl and washer kit (for motor pack)			
E40	473-430-10R		
E46/E52	473-530-10R		
E60/E66	473-630-10R		
Gear Service kit			
S30/40	470-029-11R	470-029-11,-12	472-005-11
S46/52	470-029-12R		
S60/66	472-005-11R		
Gear Shaft			
S30	473-315-01R		
S40	473-415-01R		
S46/52	473-516-01R		
S60/66	473-615-01R		
Top cover			
S30	473-314R		
S40	473-414R		
S46	473-524R		
S52	473-514R		
S60	473-624R		
S66	473-614R		

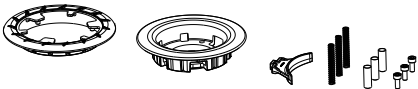
Description	Art. No.						
Self-Tailing Arm							
S30/40	473-413R						
S46/52	473-513R						
S60/66	473-613R						
Locator bracket							
S30/40	473-412R						
S46/52	473-512R						
S60/66	473-612R						
Bearing kit		 <p data-bbox="552 1018 652 1038">473-548-10</p>	 <p data-bbox="720 1018 820 1038">473-547-10</p>	 <p data-bbox="876 1018 977 1038">473-549-10</p>			
S30/40	473-548-10R						
S46/52	473-547-10R						
S60/66	473-549-10R						
Self-tailing jaws kit							
S30/40	473-429-10R						
S46/52	473-525-10R						
S60/66	473-625-10R						

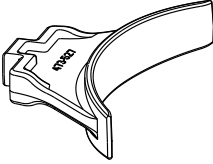
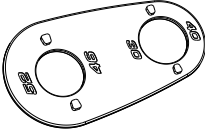
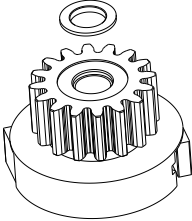
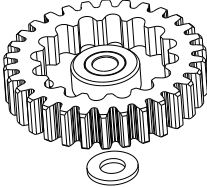
Description	Art. No.	
Line stripper		
S30/40	473-427R	
S46/52	473-527R	
S60/66	473-627R	
Winch tool		
S30/40	473-010R	
S46/52		
S60/66		
2-Speed Gear		
S30	473-321-10R	
S40	473-421-10R	
S46	473-522-10R	
S52	473-521-10R	
S60	473-622-10R	
S66	473-621-10R	
Drive Gear		
S30	320-089-10R	
S40	320-075-10R	
S46/52	320-076-10R	
S60/66	320-077-10R	

8 Disposal

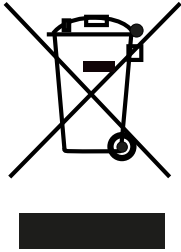

For proper treatment, recovery and recycling, please take this product(s) to designated collection points where it will be accepted free of charge. Alternatively, in some countries, you may be able to return your products to your local retailer upon purchase of an equivalent new product.

Disposing of this product correctly will help save valuable resources and prevent any potential negative effects on human health and the environment, which could otherwise arise from inappropriate waste handling.

Please contact your local authority for further details of your nearest designated collection point.

9 Warranty

Seldén Mast AB guarantees the Seldén Series-E winch for 2 years. The guarantee covers faults arising from defective design, materials, or workmanship.

The guarantee is only valid if the product is assembled, operated, and maintained in accordance with this manual and is not subjected to loads more than those specified in brochures, manuals and on the Seldén website.

Complete shipment and warranty conditions are to be found on Seldén's website www.seldenmast.com. See Resources/Partners information/General information/General conditions of sale (595-546-E).

If the winch is repaired or modified by anyone other than Seldén Mast AB or one of our authorized dealers, the guarantee ceases to be valid.

Seldén Mast AB reserves the right to alter the content and design without prior warning.

DINGHIESKEELBOATSYACHTS

*Seldén Mast AB, Sweden
Tel +46 (0)31 69 69 00
Fax +46 (0)31 29 71 37
e-mail info@seldenmast.com*

*Seldén Mast Limited, UK
Tel +44 (0) 1329 504000
Fax +44 (0) 1329 504049
e-mail info@seldenmast.co.uk*

*Seldén Mast Inc., USA
Tel +1 843-760-6278
Fax +1 843-760-1220
e-mail info@seldenus.com*

*Seldén Mast A/S, DK
Tel +45 39 18 44 00
Fax +45 39 27 17 00
e-mail info@seldenmast.dk*

*Seldén Mid Europe B.V., NL
Tel +31 (0) 111-698 120
Fax +31 (0) 111-698 130
e-mail info@seldenmast.nl*

*Seldén Mast SAS, FR
Tel +33 (0) 251 362 110
Fax +33 (0) 251 362 185
e-mail info@seldenmast.fr*

www.seldenmast.com

Dealer:

The Seldén Group is the world's leading manufacturer of masts and rigging systems in carbon and aluminium for dinghies, keelboats and yachts.

The Group consists of Seldén Mast AB in Sweden, Seldén Mast A/S in Denmark, Seldén Mast Ltd in the UK, Seldén Mid Europe B.V. in the Netherlands, Seldén Mast Inc in the USA and Seldén Mast in France.

Our well known brands are Seldén and Furlax. The worldwide success of Furlax has enabled us to build a network of over 750 authorised dealers covering the world's marine markets. So wherever you sail, you can be sure of fast access to our service, spare parts and know-how.

