

SAIL HARDWARE

V1

 **SELDÉN**

Content	Page
Batten receptacles	4
Sail Car systems.....	8
OWS	10
IWS	16
MDS	20
RCB	24
PBS	28
Toggle/Studs for batten cars	31
Sail Shackles	33
Clewblocks	35
Headboards	40
Clewboards	42
Blocks and Accessories	44
Tackboards/Headboards	48
Nail Terminals	50
AT-cables	53
Production tools	54

A Complete Partner and Supplier

This sail hardware catalogue is designed to guide sailmakers through our product range and help identify the optimal components for every sail and rig configuration. It features both well-established, proven products and recent additions that broaden our offering—each developed to support sailmakers in their daily work.

Through continuous development and refinement of our sail hardware range, we strengthen our position as a reliable one-stop shop for sailmakers worldwide.

Since the introduction of the Furlex jib furling system in 1983, sailmakers have remained one of Seldén's key customer groups. Our partnership extends far beyond products alone.

Comprehensive documentation—including all necessary measurements for both current and discontinued rig systems, Furlex systems, and downwind furlers—is available online and kept fully up to date.

Combined with daily support from our global sales team, this is another way we contribute to delivering a positive experience on the water for our mutual customer —the sailor.



SAILMAKERS GUIDE

Batten receptacles

Designed for functionality and durability, our range of batten receptacles meets the demands of mainsails from keelboats to large yachts. Carefully selected materials, smart features and a modular design deliver maximum flexibility while helping reduce inventory requirements.



Seldén's F & FA composite receptacles are designed for maximum strength relative to their size. They are available for both flat and round battens, with generous adjustment range. The models are also offered with adjustment at both the forward and aft ends.

Like their aluminium counterparts, they feature a slot in the lid for visual confirmation of the batten's position. A protective collar on the backing plate shields the forward screw heads, preventing chafe against the mast surface.



A-24 & A-34

These models are machined from black anodized aluminium and offer 50 mm of batten adjustment. The aluminium lid slides into the receptacle and can be flipped to accommodate two different batten thicknesses—a clever detail that adds versatility and minimizes the number of parts needed in stock.

A stainless-steel screw holds the lid securely in place. When the lid is open and the battens are being inserted into the sail, a safety cord prevents the lid from falling overboard. A slot in the lid allows for easy inspection of the batten's position. The backing plate is mounted with six countersunk machine screws.

Easy set up and removal of batten with sliding cover and a locking screw. No need to fully release the screw to remove the cover.



The FA-models have access to the adjustment screw both front and rear which enables adjustment of the batten even when the sail is flaked on the boom. The adjustment screw is compatible with multiple screw heads.



A-17
Art. No. 461-210-01



Composite body, Adjustment from aft, Self tapping screws

A-22
Art. No. 461-225-01



Composite body, Adjustment from aft, Self tapping screws

FA-22
Art. No. 461-220-01



Composite body, Adjustment from aft and forward, M5 screws

FA-30
Art. No. 461-230-01



Composite body, Adjustment from aft and forward, M5 screws

A-24
Art. No. 461-240-01
461-246-01 (M12)



Aluminium body, Adjustment from aft, Flippable lid, Symmetrical hole-pattern, M5 screws

A-34
Art. No. 461-250-01
461-256-01 (M12)



Aluminium body, Adjustment from aft, Flippable lid, Symmetrical hole-pattern, M6 screws

RECEPTACLES FOR FLAT BATTENS

TYPE	ART. NO	THREAD	L (mm)	W (mm)	H (mm)	ADJUSTMENT LENGTH (mm)	A (mm)	B (mm)	WEIGHT (g)	ADJUSTMENT SCREW	
										AFT	FRONT
A-17	461-210-01	M10	125	52	25	38	6	17	139	aft	
A-22	461-225-01	M10	134	62	25	33	9	22	176	aft	
FA-22	461-220-01	M10	134	62	25	33	9	22	180	aft	front
FA-30	461-230-01	M10	134	72	26	36	6	30	211	aft	front
A-24	461-240-01	M10	140	66	26	50	10 or 13*	24	-	aft	
A-24	461-246-01	M12									
A-34	461-250-01	M10	155	79	26	50	12 or 15*	34	-	aft	
A-34	461-256-01	M12									

*Flippable lid, one side for thin battens, one side for thicker batten

SCREW KIT, TITANIUM

ART. NO	THREAD	LENGTH (mm)	USED FOR...
162-002-01R	M5	12	A-24
162-003-01R	M6	16	A-34



How to mount the Batten receptacles.

A-17 Round
Art. No. 461-210-02



Composite body, Adjustment from aft, Self tapping screws

FA-22 Round
Art. No. 461-220-02



Composite body, Adjustment from aft and forward, M5 screws

FA-30 Round
Art. No. 461-230-02



Composite body, Adjustment from aft and forward, M5 screws

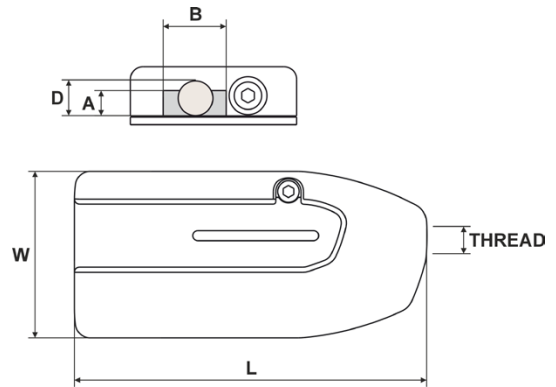

RECEPTACLES FOR ROUND BATTENS

TYPE	ART. NO	THREAD	L (mm)	W (mm)	H (mm)	ADJUSTMENT LENGTH (mm)	D (mm)	WEIGHT (g)	ADJUSTMENT SCREW	
									AFT	FRONT
A-22 Round	461-210-02	M10	125	52	25	38	8	139	aft	
FA-22 Round	461-220-02	M10	134	72	25	33	10	172	aft	front
FA-30 Round	461-230-02	M10	134	72	26	36	12	212	aft	front

P-30
Art. No. 461-237-01



Composite body, No adjustment, M5 screws

P-40
Art. No. 461-235-01



Composite body, No adjustment, M5 screws

FIXED RECEPTACLES

TYPE	ART. NO	THREAD	L (mm)	W (mm)	H (mm)	A (mm)	B (mm)	D (mm)	WEIGHT (g)
P-30	461-237-01	M10	85	56	25	5	31	10	83
P-40	461-235-01	M10	85	66	25	5	40	10	91

Sail car systems

Low-friction sail cars ensure smooth, controlled, and reliable hoisting and dousing of the mainsail. Our range includes five categories: two designed specifically for Seldén mast sections, and three that are compatible with both Seldén sections and a wide variety of mast profiles from other manufacturers.

OWS - Outer Wheel Slider

For Seldén E- and D-sections from the 70's 80's and 90's and several mast sections of other brands.



IWS - Inner Wheel Slider

For Seldén sections from 2018 –



MDS - Multi-Directional Support

For Seldén sections from 2002 –





PBS - Plain Bearing Sliders

S16 for 16mm track, S22 for 22 mm track.



RCB - Round Circulating Ballbearings

Torlon® ball bearings in linear races for minimized friction.
Available for 15 mm, 22 mm and 30 mm track systems.



OWS System

OWS is an excellent upgrade from traditional sail slides to reduce friction when hoisting and dousing the main sail. It fits earlier models of Seldén sections (E-sections and D-sections) and many other mast makes. The four wheels roll on the aft side of the mast section while the slug slides inside the luff groove. The depth and the shape of the slug is designed for dedicated mast sections and there are five different full-batten versions to chose between. Our guidelines show you which one to select.

OWS Headboard car assembly

Stainless toggle with $\varnothing 12$ mm captive pin, mounted on two composite cars.

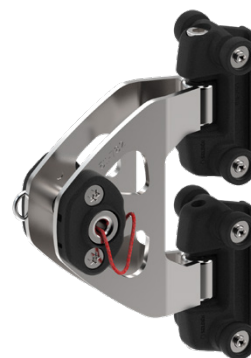

OWS Sail car

Composite car attached to the sail using webbing.



OWS Batten car

Composite car equipped with an M10 stud, designed to fit corresponding batten receptacles.



OWS Headboard car assemblies

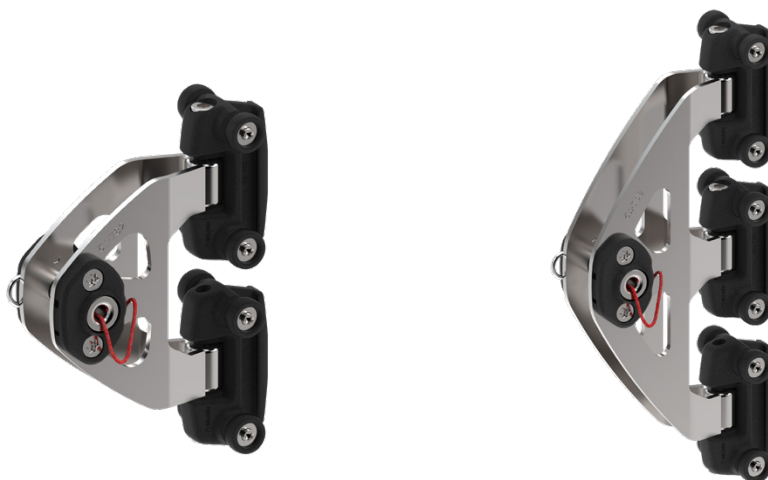

511-750-04, 511-751-04, 511-752-04, 511-753-04, 511-754-04

511-750-06, 511-751-06, 511-752-06, 511-753-06, 511-754-06

OWS HEADBOARD CAR ASSEMBLIES

ART. NO	H (mm)	A (mm)	L (mm)	øPIN (mm)	W (mm)	FITS LUFF GROOVE (mm)	SWL		MAX RM (kNm)	WEIGHT (g)	DESCRIPTION
							HORIZONTAL	(kN)			
511-750-04 2x OWS 11	141	75	50	12	21	5.50	7.00	68.00	398	OWS Car 511-750-01 (2 pcs) Headboard Toggle 511-782-01 (1 pc)	
511-750-06 3x OWS 11	223	75	50	12	21	5.50	8.80	93.00	598	OWS Car 511-750-01 (3 pcs) Headboard Toggle 511-708-01 (1 pc)	
511-751-04 2x OWS 14	141	75	50	12	21	10.00	7.00	68.00	399	OWS Car 511-751-01 (2 pcs) Headboard Toggle 511-782-01 (1 pc)	
511-751-06 3x OWS 14	223	75	50	12	21	10.00	8.80	93.00	599	OWS Car 511-751-01 (3 pcs) Headboard Toggle 511-708-01 (1 pc)	
511-752-04 2x OWS 16	141	75	50	12	21	10.00	7.00	68.00	400	OWS Car 511-752-01 (2 pcs) Headboard Toggle 511-782-01 (1 pc)	
511-752-06 3x OWS 16	223	75	50	12	21	10.00	8.80	93.00	601	OWS Car 511-752-01 (3 pcs) Headboard Toggle 511-708-01 (1 pc)	
511-753-04 2x OWS 21	141	75	50	12	21	12.00	7.00	68.00	410	OWS Car 511-753-01 (2 pcs) Headboard Toggle 511-782-01 (1 pc)	
511-753-06 3x OWS 21	223	75	50	12	21	12.00	8.80	93.00	614	OWS Car 511-753-01 (3 pcs) Headboard Toggle 511-708-01 (1 pc)	
511-754-04 2x OWS 11 Big wheel	142	77	50	12	21	5.50	7.00	68.00	411	OWS Car 511-754-01 (2 pcs) Headboard Toggle 511-782-01 (1 pc)	
511-754-06 3x OWS 11 Big wheel	226	77	50	12	21	5.50	8.80	93.00	617	OWS Car 511-754-01 (3 pcs) Headboard Toggle 511-708-01 (1 pc)	

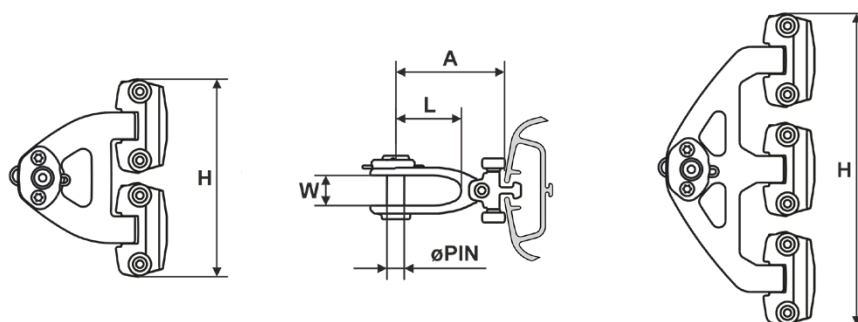

OWS Sail cars



511-740-01, 511-741-01, 511-742-01, 511-743-01, 511-744-01

OWS SAIL CARS

ART. NO	H (mm)	øD (mm)	E (mm)	FITS LUFF GROOVE (mm)	WEIGHT (g)	SWL HORIZONTAL (kN)	MAX RM (kNm)
511-740-01 OWS 11	55	8	21	5.50	49	2.50	75.00
511-741-01 OWS 14	55	8	21	10.00	49	2.50	75.00
511-742-01 OWS 16	55	8	21	10.00	49	2.50	75.00
511-743-01 OWS 21	55	8	21	12.00	44	2.50	75.00
511-744-01 OWS 11 Big wheel	57	8	21	5.50	48	2.50	75.00

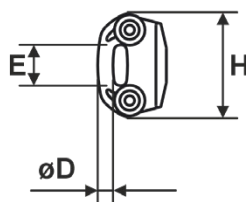

OWS batten cars



511-750-03, 511-751-03, 511-752-03, 511-753-03, 511-754-03

OWS BATTEN CARS

ART. NO	H (mm)	A (mm)	L (mm)	B (mm)	THREAD	FITS LUFF GROOVE (mm)	WEIGHT (g)	SWL HORIZONTAL (kN)	MAX RM (kNm)
511-750-03 OWS 11 (M10)	67	40	20	16	M10	5.50	100	3.50	121.00
511-751-03 OWS 14 (M10)	67	40	20	16	M10	10.00	113	3.50	121.00
511-752-03 OWS 16 (M10)	67	40	20	16	M10	10.00	113	3.50	121.00
511-753-03 OWS 21 (M10)	67	40	20	16	M10	12.00	118	3.50	121.00
511-754-03 OWS 11 Big wheel (M10)	69	42	20	18	M10	5.50	117	3.50	121.00

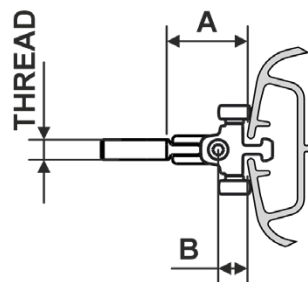
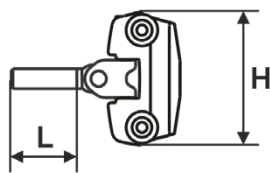

MAST SECTIONS FOR OWS

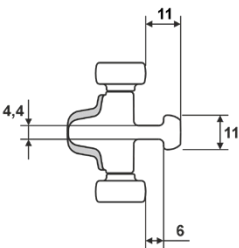
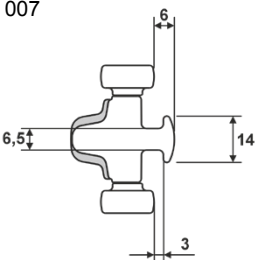
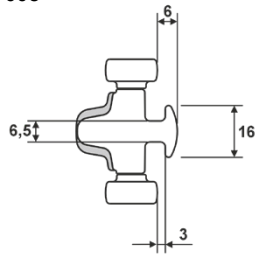
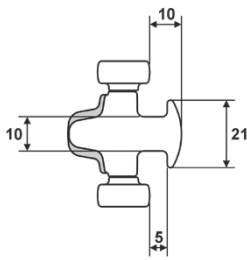
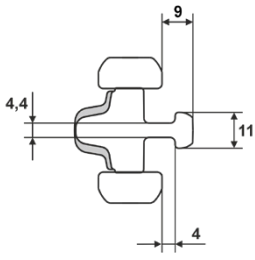
HEADBOARD CAR ASSEMBLY	SAIL CAR	BATTEN CAR	FITS LUFF GROOVE (mm)	FITS MAST SECTION (ONLY GEOMETRIC FIT)	CORRESPONDING SLIDER HOLT ALLEN BAINBRIDGE
511-750-04 511-750-06	511-740-01	511-750-03	5,5	<p>All Seldén E sections and D section (1971-2002)</p> <p>Sparcraft: F135; F195; F305; F385; F460; I620; S622; I830; S830</p> <p>Z-Spars: Z301; Z351; Z380; Z401; Z531; Z601; Z602; Z701; Z702</p> <p>Soromap: NF200; NF270; NF350; NF430; NF540; NF710; NF1410</p>	 <p>OWS 11</p>
511-751-04 511-751-06	511-741-01	511-751-03	10		<p>HA 89 A 007</p>  <p>OWS 14</p>
511-752-04 511-751-06	511-742-01	511-752-03	10	<p>Briand/Pettersson 180x130 mm MkII (Maxi 95 from hull #250)</p> <p>Briand/Pettersson 125x100 mm (Maxi 77)</p>	<p>HA 90 A 008</p>  <p>OWS 16</p>
511-753-04 511-753-06	511-743-01	511-753-03	12	<p>Isomat NG70</p> <p>Briand/Pettersson 160x120 mm (Maxi 87)</p> <p>Sparcraft: NG60; NG70; NG80; NG86; F580; F740; F1060; F1395; S1630; S2100; F2390; F3360; F4600</p> <p>Z-Spars: Z902; Z1001; Z1250; Z1400</p>	<p>HA 91 A 009</p>  <p>OWS 21</p>
511-754-04 511-754-06	511-744-01	511-754-03	5,5	<p>Seldén: C106; C116; C126; C139</p> <p>Sparcraft: F35; F50; F67; F78; F101; S137; S180;</p> <p>S260; IMS80; IMS256</p> <p>Z-Spars: Z170; Z190; Z230; Z265; Z501</p>	 <p>OWS 11 Big wheel</p>



THE IWS FULL-BATTEN SYSTEM

IWS - Inner Wheel Sliders

The composite IWS car simplifies hoisting, reefing and dousing and is used for Seldén's newest C-sections. The side load created by the full-batten is taken up by the wheels as the slider tilts to the side and a buffer bearing centers the slider in the groove.

The mast groove and the car makes for a perfect match handling loads from all direction without any extra hardware fitted to the mast. The full-batten cars come with a M10 stud and the intermediate sail cars with a bushing for webbing.



IWS 45
Art. No. 511-729-04



IWS 45 HD
Art No. 511-773-04



IWS 68
Art No. 511-760-04



IWS 68
Art. No. 511-760-05



IWS 68
Art No. 511-760-06



IWS HEADBOARD CAR ASSEMBLIES

ART. NO	H (mm)	A (mm)	L (mm)	øPIN (mm)	W (mm)	SWL		WEIGHT (g)	MAST SECTION
						HORIZONTAL (kN)	MAX RM (kNm)		
511-729-04 Headboard car assembly (2x IWS45)	120	74	46	12	21	4.80	40.00	156	C137 C153 C180
511-773-04 HD Headboard car assembly (2x IWS45 HD)	119	76	46	12	21	4.80	40.00	166	C192 C208 C225 C242 C261 C280
511-760-04 Headboard car assembly (2x IWS68)	142	76	46	12	21	4.80	40.00	228	
511-760-05 Headboard car assembly (2x IWS68)	146	76	51	12	21	7.20	71.00	-	
511-760-06 Headboard car assembly (3x IWS68)	224	76	51	12	21	9.00	97.00	647	C242 C261 C280

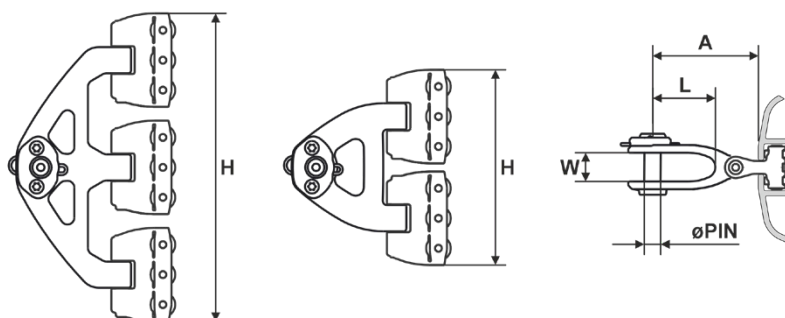

IWS 45

Art. No. 511-729-03

**IWS 45 HD**

Art. No. 511-773-03

**IWS 68**

Art. No. 511-760-03

**IWS BATTEN CARS**

ART. NO	H (mm)	A (mm)	L (mm)	B (mm)	THREAD	SWL		MAX RM (kNm)	WEIGHT (g)	MAST SECTION
						HORIZONTAL	(kN)			
511-729-03 IWS 45	46	40	33	16	M10	3.00	97.00	97.00	90	C137 C153 C180
511-773-03 IWS 45 HD	45	41	33	17	M10	3.00	97.00	97.00	95	C192 C208 C225 C242
511-760-03 IWS 68	68	41	33	17	M10	3.60	126.00	126.00	126	C261 C280

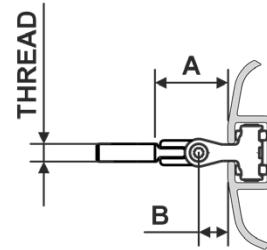
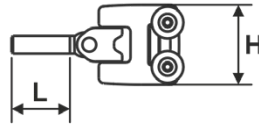
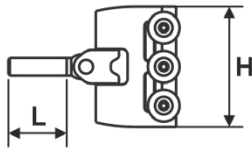



IWS 45
Art. No. 511-729-02



IWS 45 HD
Art. No. 511-773-02



IWS 68
Art. No. 511-760-02



IWS SAIL CARS

ART. NO	H (mm)	øD (mm)	E (mm)	B (mm)	SWL	MAX RM (kNm)	WEIGHT (g)	MAST SECTION
					HORIZONTAL (kN)			
511-729-02 IWS 45	46	10	20	16	3.00	97.00	48	C137 C153 C180
511-773-02 IWS 45 HD	45	10	20	17	3.00	97.00	53	C192 C208 C225 C242
511-760-02 IWS 68	68	10	20	17	3.60	126.00	84	C261 C280

To prevent chafe on the webbing, all sail cars include a PA bushing, art. no. 511-719.

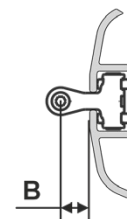
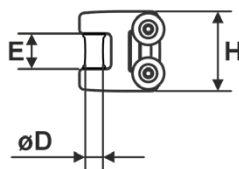
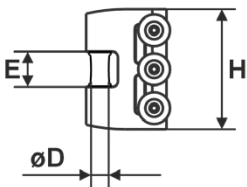

THE MDS FULL-BATTEN CONCEPT

MDS - Multi Directional Support For Seldén C-sections from 2002 and onwards

As the name implies, Seldén's MDS (Multi-Directional Support) cars are supported in all directions, making sail handling simpler. A full batten always creates a side load on the cars, particularly when you release the halyard for taking a reef. Each car has side-load absorbing wheels that run against the guiding flanges in the luff groove.

The interaction between the mast section and the MDS car deals with longitudinal loads, as well as side loads. This is the essence of the MDS concept. Since the cars need no external track, there is also less weight aloft.

The MDS cars are easy to keep clean and are easy to install or remove from the luff groove.

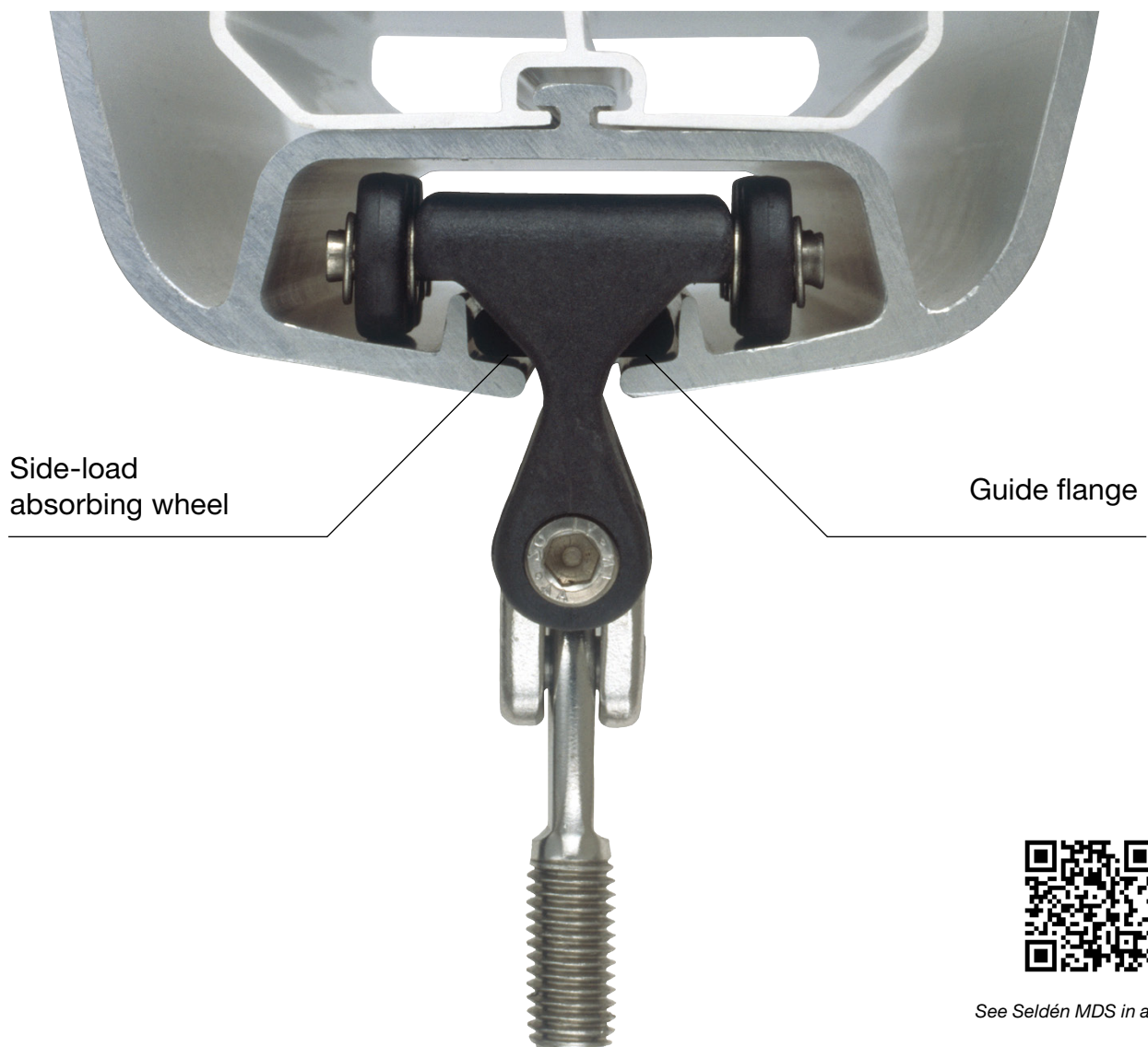

MDS 45
Art. No. 511-702-04



MDS 68
Art. No. 511-701-04



MDS 68
Art. No. 511-701-06



MDS 68 Alu
Art. No. 511-717-06



MDS 80
Art. No. 511-730-06



MDS 80 Alu
Art. No. 511-731-06



MDS HEADBOARD CAR ASSEMBLIES

ART. NO	H (mm)	A (mm)	L (mm)	øPIN (mm)	W (mm)	SWL	MAX RM (kNm)	WEIGHT (g)	MAST SECTION
						HORIZONTAL (kN)			
511-702-04 2x MDS45	119	75	46	12	21	1.60	37.00	188	C156 C175 C193
511-701-04 2x MDS68	142	75	46	12	21	4.80	40.00	282	C211 C227 C245 C264 C285 C304
511-701-06 3x MDS68	224	75	51	12	21	3.00	91.00	728	
511-717-06 3x MDS68 ALU	224	75	51	12	21	15.00	202.00	671	
511-730-06 3x MDS80	280	101	68	14	20	4.50	162.00	1372	C321 C365
511-731-06 3x MDS80 ALU	280	101	68	14	20	20.00	305.00	2039	

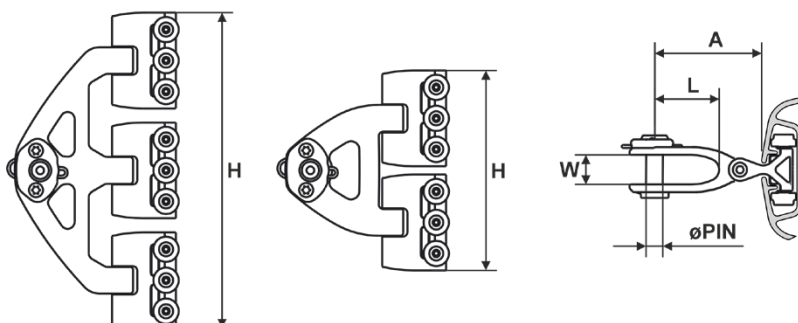

MDS 45
Art. No. 511-702-03



MDS 68
Art. No. 511-701-03



MDS 68 Alu
Art. No. 511-717-03



MDS 80
Art. No. 511-730-03



MDS 80
Art. No. 511-730-09



MDS 80 Alu
Art. No. 511-731-03



MDS 80 Alu
Art. No. 511-731-09



MDS BATTEN CARS

ART. NO	H (mm)	A (mm)	L (mm)	B (mm)	THREAD	SWL		MAX RM (kNm)	WEIGHT (g)	MAST SECTION
						HORIZONTAL (kN)				
511-702-03 MDS 45 (M10)	45	41	33	17	M10	.80		66.00	106	C156 C175 C193
511-701-03 MDS 68 (M10)	68	40	33	16	M10	1.20		118.00	153	C211 C227 C245 C264 C285 C304
511-717-03 MDS 68 Alu (M10)	68	40	33	16	M10	6.00		262.00	134	
511-730-03 MDS 80 (M10)	80	70	29	23	M10	1.80		210.00	247	C321 C365
511-730-09 MDS 80 (M12)	80	70	29	23	M12	1.80		210.00	271	
511-731-03 MDS 80 Alu (M10)	80	70	29	23	M10	9.00		468.00	469	
511-731-09 MDS 80 Alu (M12)	80	70	29	23	M12	9.00		468.00	493	

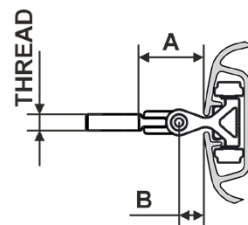
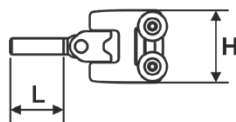
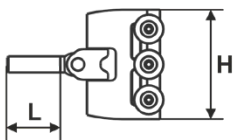

MDS 45
Art. No. 511-702-02



MDS 68
Art. No. 511-701-02



MDS 68 Alu
Art. No. 511-717-02



MDS 80
Art. No. 511-730-02



MDS 80 Alu
Art. No. 511-731-02



MDS SAIL CARS

ART. NO	H (mm)	øD (mm)	E (mm)	B (mm)	SWL		MAX RM (kNm)	WEIGHT (g)	MAST SECTION
					HORIZONTAL (kN)				
511-702-02 MDS 45	45	10	20	17	.80		66.00	64	C156 C175 C193 C211 C227 C245 C264 C285 C304
511-701-02 MDS 68	68	10	20	16	1.20		118.00	111	C211 C227 C245 C264 C285 C304
511-717-02 MDS 68 Alu	68	10	20	16	6.00		262.00	92	
511-730-02 MDS 80	80	8	20	23	1.80		210.00	165	C321 C365
511-731-02 MDS 80 Alu	80	8	20	23	9.00		468.00	387	

To prevent chafe on the webbing, all sail cars include a PA bushing, art. no. 511-719.

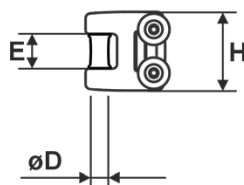
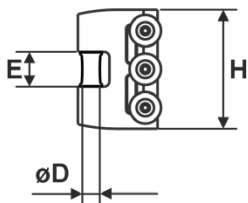

RCB

Round Circulating Ball Bearings

Seldén's RCB systems are low-friction mast track and car solutions designed specifically to handle the challenges of full-battened mainsails. The systems use Tordon® ball bearings in linear races for minimized friction even under high load sideways – all for easier hoisting, reefing and dousing of the mainsail for full control in all conditions.

A complete RCB system includes

- A headboard toggle assembly with twin cars and toggle
- One batten car per batten
- An appropriate number of intermediate sail cars
- Batten cars come with M10 studs to match the batten receptacles and allow full articulation in all directions. This ensures optimal alignment and eliminates binding under load.

Intermediate sail cars are equipped with webbing attachment eyes and are supplied separately for professional installation by the sailmaker. The swivel fittings can easily be removed from the cars simplifying sail installation and removal.

The external mast track, available in 15 mm, 22 mm or 30 mm widths, is robust and straightforward to install. A dedicated gate section at the lower end allows easy removal and refitting of cars when required. Routine rinsing with fresh water is sufficient to maintain peak performance and keep the bearings free from salt and debris.

RCB22 is available as a retrofit-friendly kit for Seldén E- and D-sections from the 1970's through the 1990's, and is also compatible with a wide range of mast sections from other manufacturers.

See Seldén Yacht Catalogue for further information.





RCB 22
Art. No. 511-595-01



RCB 30
Art. No. 511-695-01



RCB HEADBOARD CAR ASSEMBLIES

ART. NO	H (mm)	A (mm)	L (mm)	øPIN (mm)	W (mm)	WEIGHT (g)
511-595-01 2 x RCB 22	182	95	41	10	22	614
511-695-01 2x RCB 30	255	102	40	12	22	1435

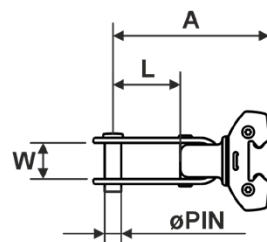
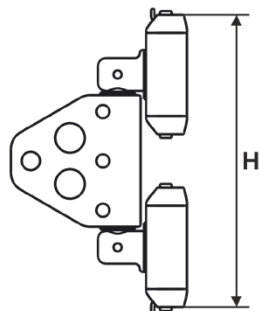



RCB 15
Art. No. 511-780-02

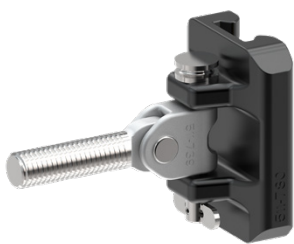

RCB 22
Art. No. 511-581-03

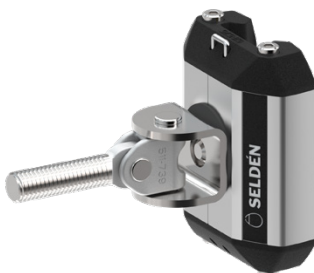

RCB 30
Art. No. 511-681-03



RCB BATTEN CAR ASSEMBLIES

ART. NO	H (mm)	A (mm)	L (mm)	B (mm)	THREAD	WEIGHT (g)
511-780-02 RCB 15	56	43	33	19	M10	148
511-581-03 RCB 22	77	64	33	40	M10	284
511-681-03 RCB 30	108	71	33	47	M10	620

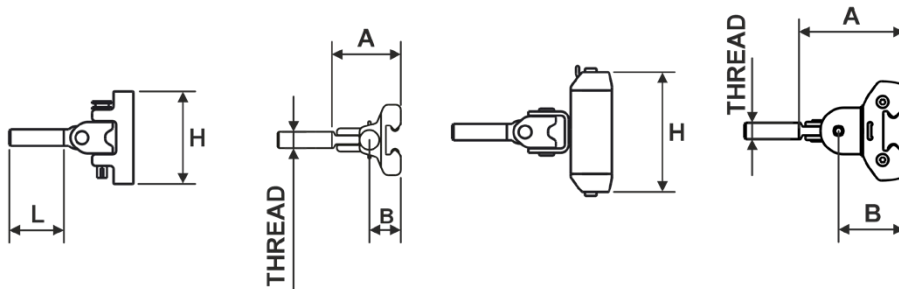

RCB 15

RCB 22/30

RCB 15
Art. No. 511-780-01



RCB 15
Art. No. 511-780-03



RCB 22
Art. No. 511-581-04



RCB 30
Art. No. 511-681-04



RCB 30
Art. No. 511-682-03



RCB SAIL CARS

ART. NO	H (mm)	B (mm)	D (mm)	E (mm)	WEIGHT (g)
511-780-01 RCB 15	56	16.00	10	19	106
511-780-03 RCB 15	56	16.00	6	20	105
511-581-04 RCB 22	77	42.00	12	18	223
511-681-04 RCB 30	108	51.00	13	18	587
511-682-03 RCB 30	82	51.00	13	18	484

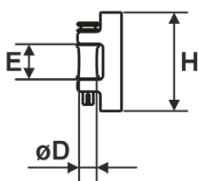

RCB 15

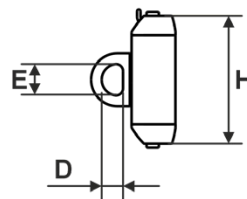

RCB 22/30



PBS – Plain Bearing Slider

A lightweight solution featuring a PA66 body for excellent strength and stiffness, or alternatively aluminium, combined with PTFE sliding inserts that provide low friction and high heat resistance.

PBS sliders are designed for use with 16 mm and 22 mm tracks on our carbon fibre masts and are primarily used as mainsail sliders. The 22 mm version is also suitable for trysail applications when used with an RCB22 track.

The PBS slider is compatible with Seldén headboard fittings as well as an M10 stud for full-batten receptacles.



PBS 22
Art. No. 511-687-02



PBS 22
Art. No. 511-687-03



PBS HEADBOARD SLIDER ASSEMBLIES

ART. NO	MODEL	H (mm)	A (mm)	L (mm)	øPIN (mm)	W (mm)	WEIGHT (g)
511-687-02	2 x PBS22	124	86	46	12	21	106
511-687-03	3x PBS22	206	86	51	12	21	105

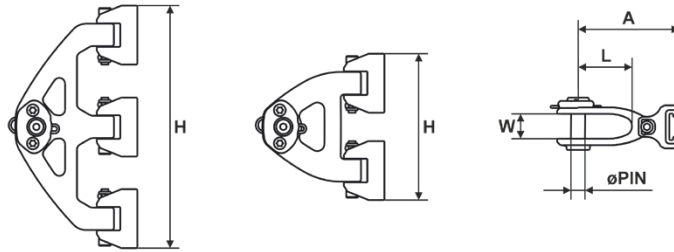

PBS 16
Art. No. 511-733-02



PBS 16 Alu
Art. No. 511-766-02



PBS 22
Art. No. 511-686-03

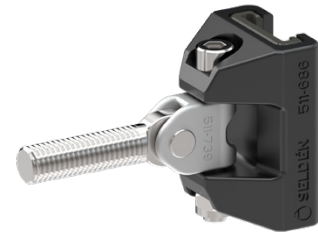

PBS BATTEN SLIDERS

ART. NO	MODEL	H (mm)	A (mm)	L (mm)	B (mm)	THREAD	WEIGHT (g)
511-733-02	PBS 16	50	43	33	19	M10	47
511-766-02	PBS 16 Alu	45	43	33	19	M10	73
511-686-03	PBS 22	50	47	33	23	M10	113



Sail Sliders

PBS 16
Art. No. 511-733-01



PBS 16
Art. No. 511-733-03



PBS 16
Art. No. 511-733-05



PBS 16
Art. No. 511-766-01



PBS 16
Art. No. 511-766-03



PBS 16
Art. No. 511-766-05



PBS 22
Art. No. 511-686-02



PBS SAIL SLIDERS

ART. NO	DESCRIPTION	H (mm)	øD (mm)	E (mm)	B (mm)	WEIGHT (g)
511-733-01	PBS 16 Sail slider	45	10.00	20	19	23
511-733-03	PBS 16 Sail slider (Clevis pin and Split ring)	45	6.00	20	19	28
511-733-05	PBS 16 Sail slider (Bushing, Screw and Nut)	45	10.00	20	19	34
511-766-01	PBS 16 ALU Sail slider	45	10.00	20	19	33
511-766-03	PBS 16 Sail slider ALU (Clevis pin and Split ring)	45	6.00	20	19	63
511-766-05	PBS 16 Sail slider ALU (Bushing, Screw and Nut)	45	10.00	20	19	31
511-686-02	PBS 22 Sail slider (Bushing, Screw and Nut)	50	10.00	20	23	71

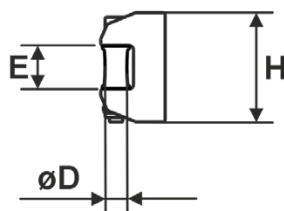

Toggle/Studs for batten cars

Art. No. 511-727-01



Art. No. 511-727-02



Art. No. 511-739-02



Art. No. 511-739-03



TOGGLE BATTEN CAR

ART. NO	THREAD, Ø mm	CAR	TL (mm)	ØD (mm)	L (mm)	H (mm)	W (mm)	WEIGHT (g)
511-727-01	12	MDS80	29	8	56	24	18	106
511-727-02	10	MDS80	29	8	56	24	18	82
511-739-02	10	MDS 45/68 OWS	30	6	58	19	11	58
511-739-03	10	IWS 45/68 PBS 16/22	33	6	44	19	11	43

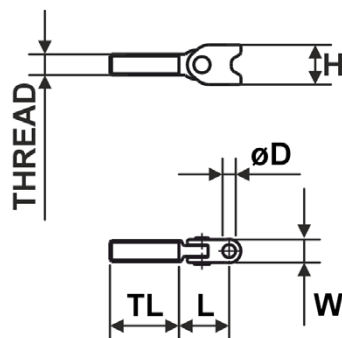

Sail Slides



SAIL SLIDES

ART. NO	BREAKING LOAD (kN)	FOR LUFF GROOVE (mm)	L (mm)	W (mm)	T (mm)	A (mm)	SW (mm)	SL (mm)	WEIGHT (g)	ITEM # 2
511-601	.70	4.00	25	11	3	5.80	15.00	5.50	3	A013
511-602	2.25	5.00	30	14	4	6.60	13.00	8.00	6	A014
511-603	4.00	5.50	40	15	4	7.00	19.00	9.00	11	A015
511-605	2.25	10.00	30	20	8	5.10	15.00	8.00	9	A011
511-607	4.00	10.00	40	20	8	5.10	19.00	9.00	14	A012
511-675	2.25	8.00	30	15	7	-	7.00	15.00	4	A007
511-676	2.25	10.00	32	18	9	-	7.00	15.00	5	A008
511-677	2.25	12.00	35	22	11	-	7.00	15.00	8	A009

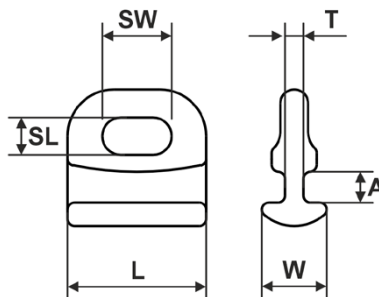

Sail Shackles

Art. No. 307-067-01



Art. No. 307-066-01



Art. No. 307-094-01



SHACKLES FOR SLIDES

ART. NO	BREAKING LOAD (kN)	Pin (mm)	R (mm)	L (mm)	H (mm)	W (mm)
307-067-01	2.00	8.50	5	33	50	8.50
307-066-01	2.00	8.50	5	39	56	8.50
307-094-01	2.00	8.50	5	45	62	8.50

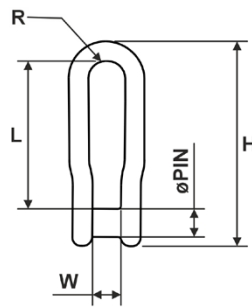



Clewblocks

Our clewblocks are designed specifically for furling mainsails. These compact yet robust blocks feature stainless-steel bodies combined with either a precision-machined, anodized aluminium sheave or a stainless-steel low friction insert.

The Seldén clewblock is significantly smaller than comparable products on the market. Made of stainless steel, the body of the block allows for tight attachment points between the webbing bands. Being placed close to each other, wrinkles between the webbings are prevented. Reduced size minimizes sailcloth waste. The removable sheave, or low friction insert, allow for easy installation of outhaul to the sail. Only the sheave/low friction insert is dismantled, and the locking pin is captive.



CLB10
Art. No. 462-302-01



CLB15
Art. No. 462-402-01



CLB25
Art. No. 462-502-01



CLB40
Art. No. 462-702-01



CLEWBLOCKS, DETACHABLE SHEAVE

ART. NO	MODEL	SWL (kN)	BREAKING LOAD (kN)	V (mm)	H (mm)	øD (mm)	W (mm)	B WEBBING (mm)	WEIGHT (g)	ød (Max Line) (mm)	MAX RM FR (kNm)	MAX RM MH (kNm)	MAX REC. BOAT SIZE* (Feet)
462-302-01	CLB10	10.00	20.00	71	68	40	19	3x25	261	12	65	85	44
462-402-01	CLB15	15.00	30.00	74	70	40	23	3x25	317	14	115	150	54
462-502-01	CLB25	25.00	50.00	103	98	60	27	4x25	737	16	240	320	65
462-702-01	CLB40	40.00	80.00	150	142	100	39	4x40	1420	18	450	600	80

* Please note, guidelines only.

RM=Righting moment at 30° heel angle
FR=Fractional rig
MH=Masthead rig

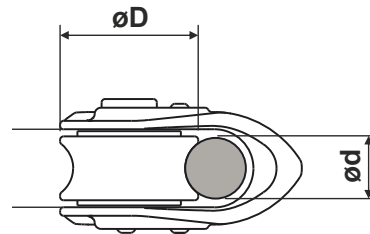
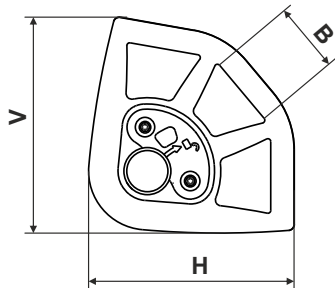

CLB10-LFI
Art. No. 462-302-02



CLB15-LFI
Art. No. 462-402-02



CLB25-LFI
Art. No. 462-502-02



CLEWBLOCKS, DETACHABLE LOW FRICTION INSERT

ART. NO	MODEL	SWL (kN)	BREAKING LOAD (kN)	V (mm)	H (mm)	øD (mm)	W (mm)	B WEBBING (mm)	WEIGHT (g)	ød (Max Line) (mm)	MAX RM FR (kNm)	MAX RM MH (kNm)	MAX REC. BOAT SIZE* (Feet)
462-302-02	CLB10-LFI	10.00	20.00	73	70	40	19	3x25	290	12	65	85	44
462-402-02	CLB15-LFI	15.00	30.00	75	72	40	23	3x25	350	14	115	150	54
462-502-02	CLB25-LFI	25.00	50.00	105	100	60	27	4x25	777	16	240	320	65

* Please note, guidelines only.

RM=Righting moment at 30° heel angle
FR=Fractional rig
MH=Masthead rig

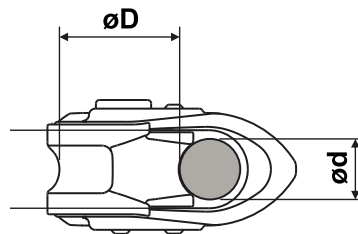
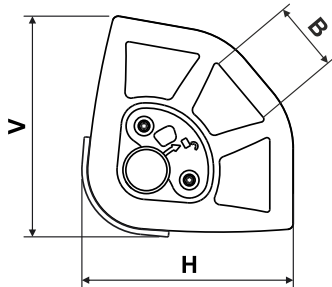

SPARE SHEAVE

ART. NO	SAFE WORKING LOAD (kN)	BREAKING LOAD (kN)	øD (mm)	ød (mm)	W (mm)	WEIGHT (g)	TO BE USED IN CLEW BLOCK
462-301-01R	10.00	20.00	40	14	18	49	CLB10
462-401-01R	15.00	30.00	40	14	22	60	CLB15
462-501-01R	25.00	50.00	60	19	26	151	CLB25
462-701-01R	40.00	80.00	100	19	26	243	CLB40

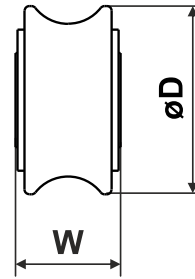
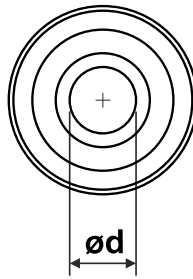

SPARE LOW FRICTION INSERT

ART. NO	SAFE WORKING LOAD (kN)	BREAKING LOAD (kN)	øD (mm)	ød (mm)	W (mm)	WEIGHT (g)	TO BE USED IN CLEW BLOCK
462-307	10.00	12.00	42	14	18	78	CLB10-LFI
462-407	15.00	30.00	42	14	22	93	CLB15-LFI
462-507	25.00	50.00	62	19	26	193	CLB25-LFI

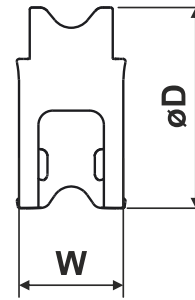
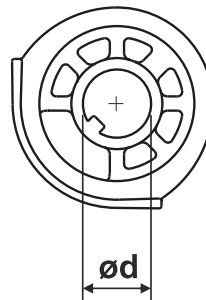



 **SELDÉN**

Headboards

Crafted from black anodized aluminium, these headboards are designed for easy attachment to the sail—either by riveting or with stainless steel liners.

In addition to the pre-drilled hole for the main halyard, optional holes for various headboard toggles can be added upon sail delivery. This modular approach allows for a more flexible inventory and reduces the number of required variants.

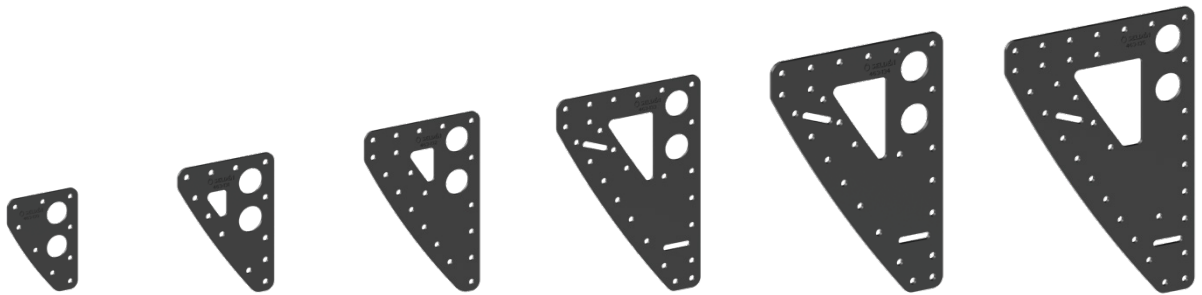
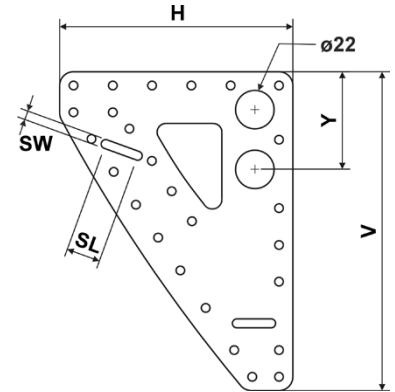

Art. No. 463-130 Art. No. 463-131 Art. No. 463-132 Art. No. 463-133 Art. No. 463-134 Art. No. 463-135

HEADBOARD FOR RIVETS

ART. NO	MODEL	H (mm)	V (mm)	THICKNESS (mm)	Y (mm)	RIVETS REQUIRED	SWxSL (mm)	WEIGHT (g)	MAX REC. BOAT SIZE* (Feet)
463-130	HBR, 75x100x2	75	100	2	55	9	-	25	30
463-131	HBR, 90x120x2	90	120	2	55	12	-	32	37
463-132	HBR, 112x160x2	112	160	2	60	20	-	56	40
463-133	HBR, 135x185x2	135	185	2	60	26	5 x 25 (2x)	74	45
463-134	HBR, 135x185x3	135	185	3	60	26	5 x 25 (2x)	112	50
463-135	HBR, 160x220x3	160	220	3	60	34	5 x 25 (2x)	152	50

* Please note, guidelines only.

Seldén offers five types of headboards, designed to accommodate seven different applications.

The two largest headboards (463-123 and 463-124) can be oriented in two ways: either with the longer edge facing the mast, or facing upward to provide a broader sail head. For this reason, they feature two unriveted areas intended to be drilled for a Ø12 mm toggle pin.

All headboards are delivered without a pre-drilled hole for the toggle pin. This is intentional, allowing the sailmaker to drill the hole in the optimal position for each specific sail.

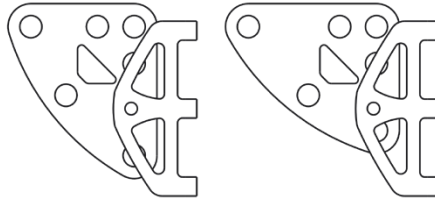
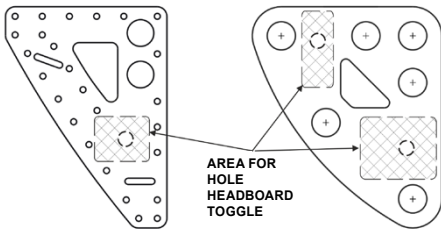
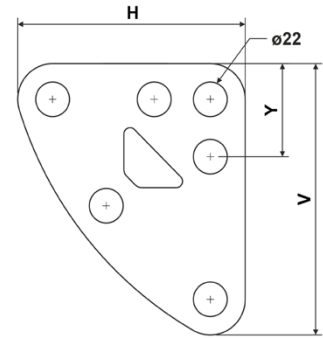

Art. No. 436-120



Art. No. 436-121



Art. No. 436-122



Art. No. 436-123

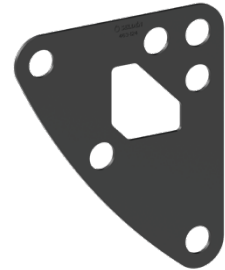

Art. No. 436-124

HEADBOARD FOR LINERS

ART. NO	MODEL	H (mm)	V (mm)	THICKNESS (mm)	Y (mm)	LINERS REQUIRED	WEIGHT (g)	MAX REC. BOAT SIZE* (Feet)
463-120	HBL, 80x115x2	80	115	2	-	3	23	30
463-121	HBL, 112x150x3	112	150	2	74	4	70	37
463-122	HBL, 135x160x3	135	160	3	74	6	90	40
463-123	HBL, 150x175x3	150	175	3	105	6	113	50
463-124	HBL, 185x158x3	185	215	3	105	6	156	50

* Please note, guidelines only.

Clewboards

Two ranges of clewboards for self-tacking jibs—one designed to be fitted to the sail using stainless steel liners, the other using webbing.

Both versions are machined black anodized aluminium, featuring well-rounded edges and a smooth finish to ensure durability and gentle sail handling.

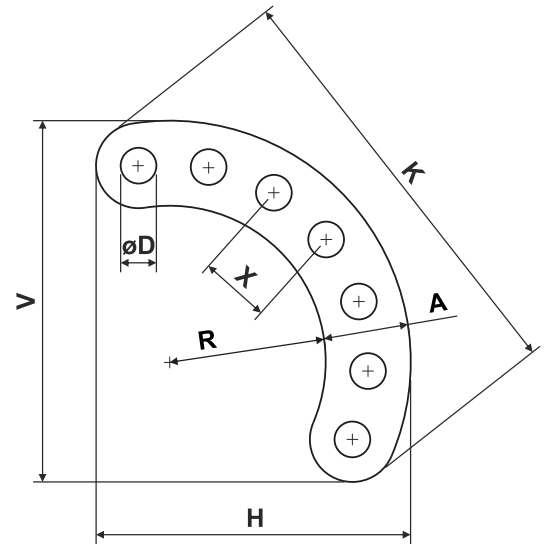

Art. No. 463-010

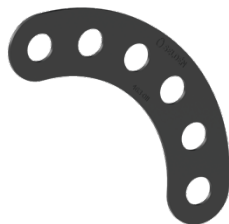

Art. No. 463-011



Art. No. 463-012

CLEWBOARDS FOR LINERS

ART. NO	MODEL	V (mm)	H (mm)	K (mm)	THICKNESS (mm)	R (mm)	A (mm)	D (mm)	X (mm)	WEIGHT (g)	MAX REC. BOAT Size* (Feet)
463-010	CBL 142x142x3	142	142	182	3	85.00	45.00	23	37	50	34
463-011	CBL 199x199x3	199	199	258	3	105.00	55.00	25.2	46	98	44
463-012	CBL 239x239x4	239	239	305	4	110.00	60.00	25.2	50	186	54

* Please note, guidelines only.

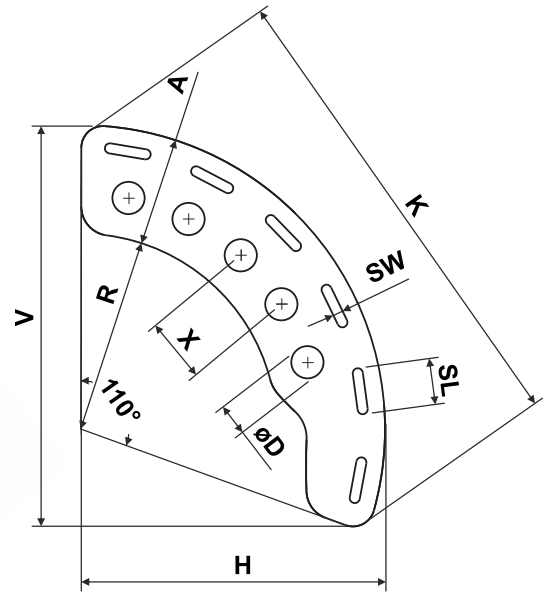

Art. No. 463-003-01



Art. No. 463-004-01



Art. No. 463-005-01



Art. No. 463-006-01

CLEWBOARDS FOR WEBBING

ART. NO	MODEL	V (mm)	H (mm)	K (mm)	THICKNESS (mm)	D (mm)	X (mm)	R (mm)	A (mm)	WEBBING (SLxSW)	WEIGHT (g)	MAX REC. BOAT Size* (Feet)
463-003-01	CBW 144x110x6	144	110	172	6	12.4	27	65	45	24x6	97	34
463-004-01	CBW 196x146x8	196	146	233	8	17.4	35	90	60	27x7	223	44
463-005-01	CBW 217x210x10	217	210	331	10	20	44	135	75	32x7	537	54
463-006-01	CBW 357x270x15	357	270	429	12	26	64	175	95	41x9	1047	64

* Please note, guidelines only.

Blocks and Accessories

Ball bearing blocks are used where the loads are more moderate and dynamic. The ball bearings provide for good sheave rotation with the lowest possible friction.

This is a selection from our wide range of blocks. See the Deck Hardware catalogue for our complete range.



Art. No. 402-101-13
Single, cheek



Art. No. 402-101-12
Single, tie-on



Art. No. 402-101-60
Single, soft attachment

BLOCKS FOR LEECH LINES

ART. NO	SAFE WORKING LOAD (kN)	DESCRIPTION	BREAKING LOAD (kN)	MAX LINE SIZE (mm)	WEIGHT (g)
402-101-13R	1.00	BBB20, cheek block	2.00	6	7
402-101-12R	1.00	BBB20, Single Tie-on	2.00	6	7
402-101-60R	1.50	S20, ball-bearing block, soft attachment, Acetal sheave, lashing incl.	3.00	6	9
402-101-65R	2.00	S20, ball-bearing block, soft attachment, aluminium sheave	4.00	6	16
403-101-09R	2.00	BBB30, cheek block	4.00	8	23
403-101-08R	2.00	BBB30, Single Tie-on	4.00	8	22
403-101-60R	2.00	S30, ball-bearing block, soft attachment, Acetal sheave, lashing incl.	4.00	8	21
404-101-17R	2.50	BBB40, cheek block	5.00	10	130
404-101-16R	2.50	BBB40, Single Tie-on	5.00	10	132
404-101-60R	2.50	S40, ball-bearing block, soft attachment, Acetal sheave, lashing incl.	5.00	10	47
404-101-65R	4.00	S40+, ball-bearing block, soft attachment, aluminium sheave, lashing incl.	8.00	10	63

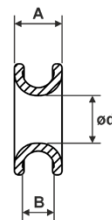
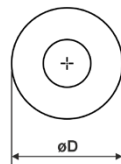
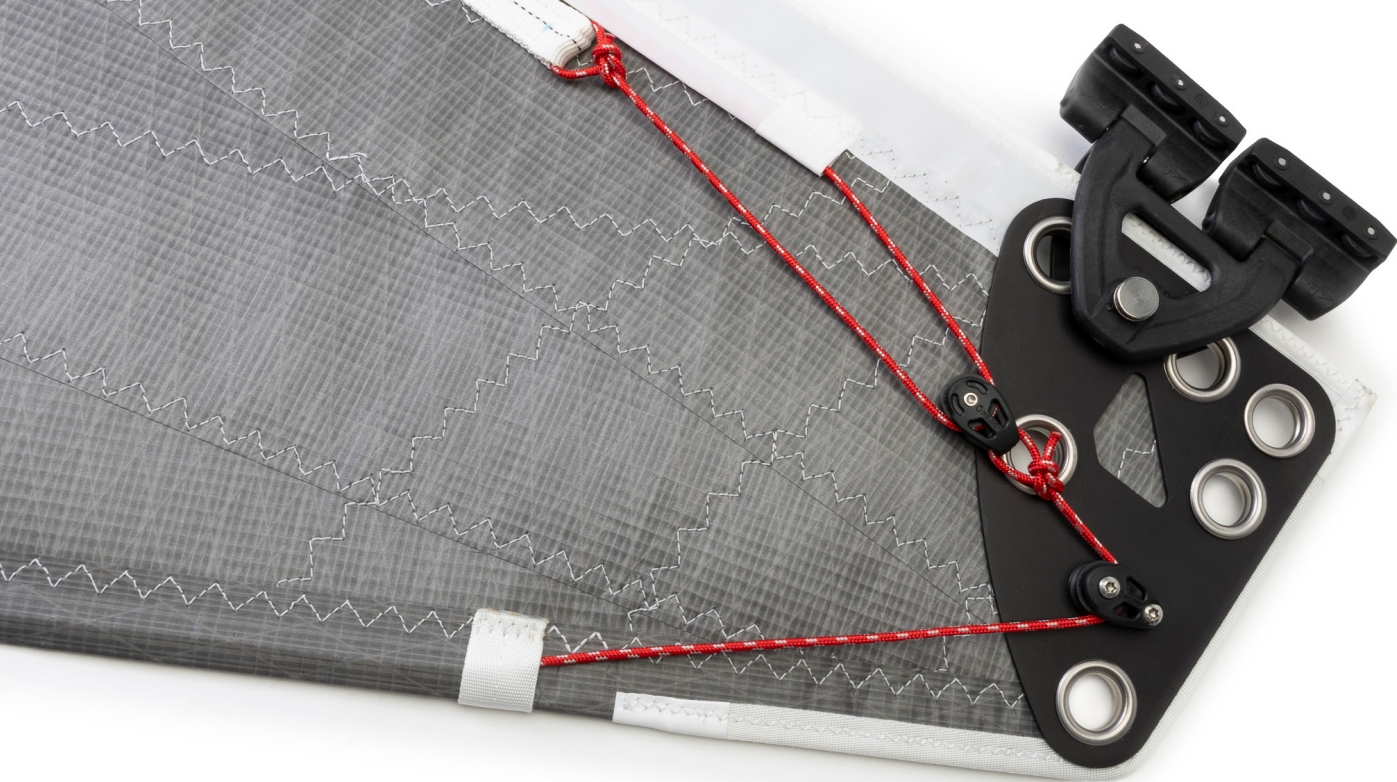

LOW FRICTION RING

ART. NO	øD	ød	A (mm)	B (mm)	SAFE WORKING LOAD (kN)	BREAKING LOAD (kN)	MAX LINE SIZE (mm)	WEIGHT (g)
420-500	12	5	5	3	1.50	3.00	3	1
420-501	18	8	8	5	3.50	7.00	5	2
420-502	25	11	11	6	7.50	15.00	7	5
420-503	35	16	16	9	15.00	30.00	10	13
420-504	50	22	22	12	30.00	60.00	14	44
420-505	70	30	30	18	60.00	120.00	20	116



Valley Cleats

Valley cleats provide fast, reliable line management for leech lines from 3–6 mm. Available in port and starboard versions, the aluminum construction prevents rope burn under higher loads while keeping weight low.



Art. No. 432-021



Art. No. 432-022



Art. No. 432-033



Art. No. 432-034

VALLEY CLEATS FOR LEECH LINES

ART. NO	MAX LINE SIZE (mm)	MIN LINE SIZE (mm)	HOLE SPACING (mm)	MOUNTING	WEIGHT (g)
432-021R	6	3	49	2xM4	19
432-022R	6	3	49	2xM4	19
432-033R	6	3	49	2xM4	16
432-034R	6	3	49	2xM4	16

Aluminium cleats designed and produced for Seldén by Clamcleat Ltd, UK.



Liners

Stainless steel liners precision-manufactured for use in headboards and clewboards. Available in five lengths — 13, 16, 19, 22 and 26.5 mm — with an outer diameter of 22 mm and inner diameter of 20 mm, to accommodate different board thicknesses.

LINERS

ART. NO	DESCRIPTION	D1 (mm)	D2 (mm)	L (mm)	WEIGHT (g)
463-230	Liner ø22/20-13	22	20	13	7
463-231	Liner ø22/20-16	22	20	16	8
463-232	Liner ø22/20-19	22	20	19	10
463-233	Liner ø22/20-22	22	20	22	12
463-234	Liner ø22/20-27	22	20	26	14

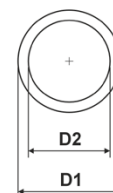
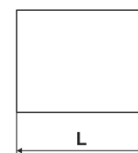

Tackboards Headboards

With the growing popularity of cableless Code sails, Seldén offers a range of tack boards and headboards suitable for the CX furlers, CXr and CXe. Manufactured from machined aluminium, these boards are designed in close collaboration with leading sailmakers.

- **Optimized Load Distribution:** Attachment holes for webbing are placed and angled to distribute the loads for optimized sail shape and long term service life of the sail.

- **Low Furling Resistance:** While the sections that connect to the furling drum and halyard swivel provide a secure, snug fit, the remaining areas are made as thin as possible to minimize initial resistance during furling.



- **Durable Construction:** Hard anodizing enhances corrosion resistance and durability in marine environments.

- **Additional Lashing Option:** Each board includes an extra attachment hole, allowing the use of a Dyneema® lashing if required.

These tack and headboards are purpose-built to meet the unique demands of cableless sail systems, combining ease of furling with improved sail handling and performance.

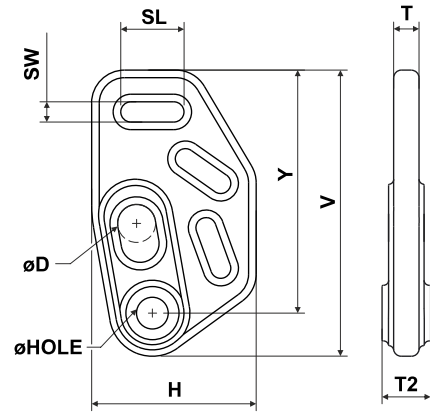

TACKBOARDS

ART. NO	USED FOR...	øHOLE (mm)	H (mm)	V (mm)	T (mm)	T2 (mm)	øD (mm)	SLxSW (mm)	SAFE WORKING LOAD (kN)	WEIGHT (g)
546-150R	CX 15, CXr 15	10.50	53	93	8	16	12	21x7	15	81
546-250R	CX 25, CXr 25, CXe 25	12.50	65	113	10	19	15	25x8	25	147
546-450R	CX 45, CXr 45, CXe 45	16.50	82	144	13	20	19	33x10	45	292

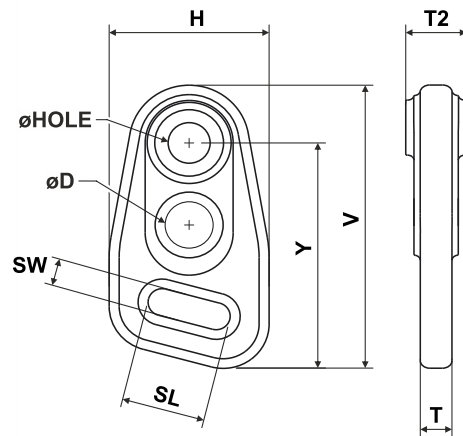

HEADBOARDS

ART. NO	USED FOR...	øHOLE (mm)	H (mm)	V (mm)	øD (mm)	T (mm)	T2 (mm)	Y (mm)	SLxSW (mm)	SAFE WORKING LOAD (kN)	WEIGHT (g)
546-151R	CX 15, CXr 15	10.50	40	73	12	8	16	58	21x7	15	53
546-251R	CX 25, CXr 25, CXe 25	12.50	47	93	15	10	19	76	25x8	25	96
546-451R	CX 45, CXr 45, CXe 45	16.50	62	116	19	13	20	93	33x10	45	188

Nail Terminal for AT-Cables



Seldén's Nail Terminal is a solution for Anti-Torsion cables, developed to enable quick, safe, and reliable assembly of Code 0 furling systems.

Machined from aluminium and hard cote anodized, the terminal features a female fitting into which the AT-cable is inserted. Sharp, hardened stainless steel nails are then driven through the terminal and the AT-cable—either with a vise or by hammering. The specially designed nails ensure that the Dyneema® fibers within the cable remain undamaged, preserving both the load-bearing capacity and the torsional rigidity of the AT-cable.

In addition to the standard Nail Terminal (NT), two alternative versions are available - One-Step-Down terminal (OSD) and Nail Terminal Lashing (NTL).



ONE-STEP-DOWN TERMINAL (OSD)

A One Step-Down (OSD) version is offered for each furling unit, intended for use with Code sails equipped with a smaller dimension AT-cable.

Allows the use of an AT-cable one size smaller than the standard dimension for CX/CXr/CXe systems. 301-315-01, 301-316-01, 301-317-01.

Please note that the safe working load (SWL) for these configurations does not correspond to the SWL of the furling unit itself.

For top-down furling of an asymmetric spinnaker or gennaker, always follow Seldén's standard recommendations for AT-cable dimensions.



How to attach the AT-cable to the nail terminal

Nail terminal

NT-9
Art. No. 301-315-01



NT-11
Art. No. 301-305-01



NT-13
Art. No. 301-306-01



NT-15
Art. No. 301-307-01



NAIL TERMINAL

ART. NO	MODEL	FOR AT-CABLE, ø mm...	USED FOR...	L (mm)	W (mm)	D1 (mm)	Y (mm)	CCL (mm)	D2 (mm)	SL (mm)	SW (mm)	SWL (kN)	WEIGHT (g)
301-315-01	NT-9 OSD	9	CX10/15 CXr15	165	16	22	13	59	10.4	22	10.5	10	111
301-305-01	NT-11	11		165	16	22	13	59	10.4	22	10.5	15	144
301-316-01	NT-11 OSD	11	CX25 CXr25 CXe25	172	20	24	15	64	12.4	22	10.5	15	165
301-306-01	NT-13	13		184	20	24	15	64	12.4	22	10.5	25	212
301-317-01	NT-13 OSD	13	CX45 CXr45 CXe45	198	20.5	31	17	76	16.4	25	13	25	383
301-307-01	NT-15	15		235	20.5	31	17	76	16.4	25	13	45	383

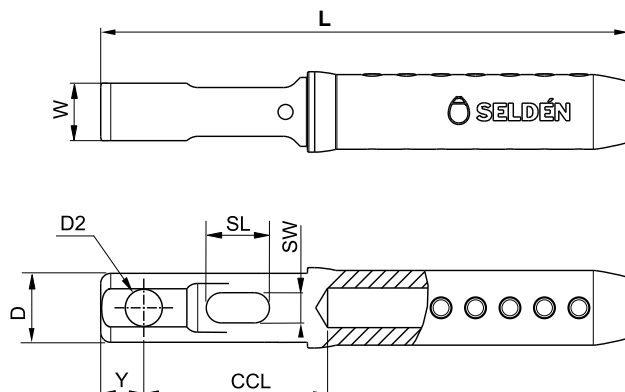

Nail terminal lashing

Lashing Terminal

Intended for cable-less Code sails where the luff requires vertical reinforcement and improved torsional properties. A smoothly rounded hole enables secure lashing to attachment points at the head and tack of the sail.



NLT-9
Art. No. 301-325-01



NLT-11
Art. No. 301-326-01



NLT-13
Art. No. 301-327-01



NAIL TERMINAL LASHING

ART. NO	MODEL	FOR AT-CABLE, ø mm...	L (mm)	W (mm)	D (mm)	Y (mm)	CCL (mm)	SL (mm)	SW (mm)	SWL (kN)	WEIGHT (g)
301-324-01	NTL-7	7	97	8	17	7	22	15	8.5	7	36
301-325-01	NTL-9	9	128	8	19.5	8	26	17	8.5	10	65
301-326-01	NTL-11	11	134	10.5	24	9	32	22	10.5	15	96
301-327-01	NTL-13	13	153	12	28	9.5	39	25	13	25	141

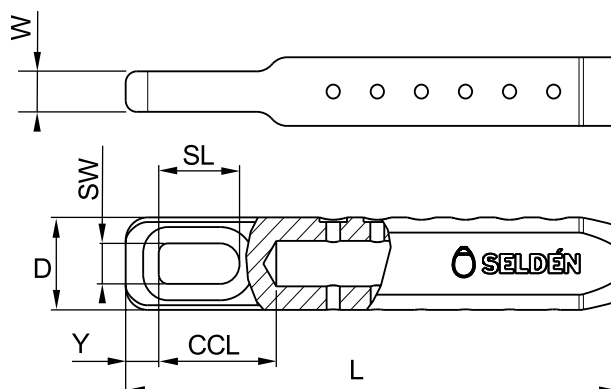

AT-cables (Anti-Torsion)

The more torsional rigid AT-cable, the quicker and safer the sail will furl. Seldén provide the most rigid cable on the market, three times more rigid than the second best.



AT-CABLES

ART. NO	LENGTH, mm	DIMENSION, Ø mm	TO BE USED FOR...	
			PREVIOUS MODELS	CURRENT MODELS
613-020-01	13000	9	CX10	
613-020-02	16000		GX7,5	
613-020-03	19000		CX10 + GX7,5 adapter	
613-021-01	13000	11	GX10	CXr15
613-021-02	16000		CX15	
613-021-03	19000		CX15 + GX10 adapter	
613-021-04	22000			
613-022-01	16000	13	GX15	CXr25 CXe25
613-022-02	19000		CX25	
613-022-03	22000		CX25 + GX15 adapter	
613-022-04	25000			
613-022-05	28000			
613-023-01	19000	15	CX45	CXr45 CXe45
613-023-02	22000		GX25	
613-023-03	25000		CX45 + GX25 adapter	
613-023-04	28000			



Production tools

Seldén provides 3D-printable file templates so you can verify hardware fit and positioning before the sail goes into production.

3D TEMPLATES FOR BATTEN RECEPTACLES

ART. NO	DESCRIPTION	L (mm)	W (mm)	THREAD (mm)	A (mm)	B (mm)	D (mm)
461-910-01	A-17 Template	125	52	M10	6	17	8
461-920-01	A-22 Template	134	62	M10	9	22	10
461-930-01	FA-30 Template	134	72	M10	6	30	12
461-940-01	A-24 Template	140	66	M10	10 or 13*	24	-
461-950-01	A-34 Template	155	79	M10	12 or 15*	34	-

* Reversible lid, one side for thin battens, one side for thicker batten



3D TEMPLATES FOR CLEW BLOCK

ART. NO	DESCRIPTION
462-490-01	CLB Cut out temp.

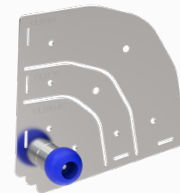

PUNCHING TOOLS FOR LINERS

ART. NO	USED FOR... Ø mm
592-126	13,8/12,4
592-127	18,4/17,4
592-128	22/20
592-129	28/26

Table dimensions corresponds to the intended liner for that specific tool.





3D template for attaching batten receptacles

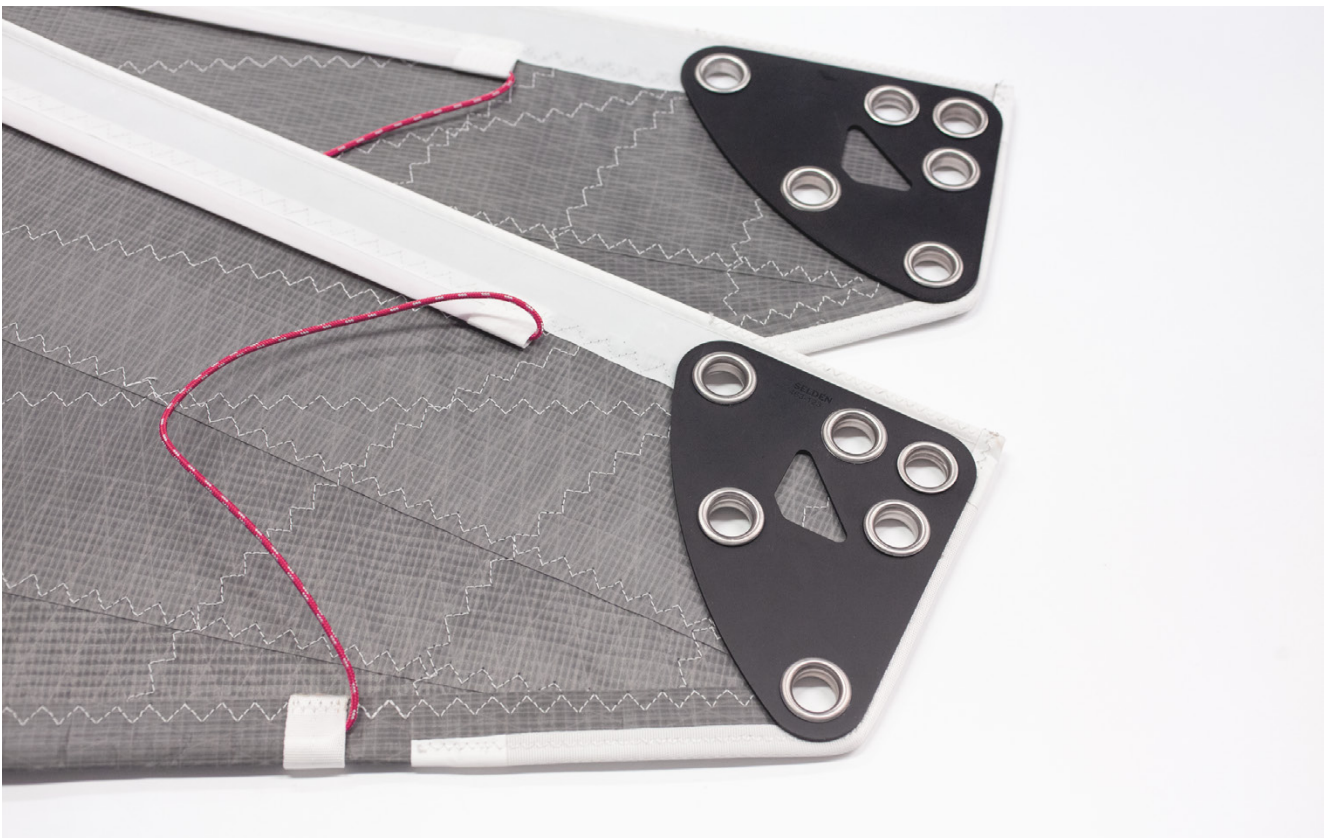

Sail Hardware by Tradition



www.seldenmast.com/products/sail-hardware/

DINGHIES KEELBOATS YACHTS

Seldén Mast AB, Sweden
Tel +46 (0)31 69 69 00
e-mail info@seldenmast.com

Seldén Mast Limited, UK
Tel +44 (0)1329 50 40 00
e-mail info@seldenmast.co.uk

Seldén Mast Inc., USA
Tel +1 843-760-6278
e-mail info@seldenus.com

Seldén Mast A/S, Denmark
Tel +45 39 18 44 00
e-mail info@seldenmast.dk

**Seldén Mid Europe B.V.,
Netherlands**
Tel +31 (0)111-698 120
e-mail info@seldenmast.nl

Seldén Mast SAS, France
Tel +33 (0)251 362 110
e-mail info@seldenmast.fr

www.seldenmast.com

The Seldén Group is the world's leading manufacturer of mast and rigging systems in carbon and aluminium for dinghies, keelboats and yachts.

Our well known brands are Seldén and Furlex. The worldwide success of Furlex has enabled us to build a network of over 750 authorised dealers covering the world's marine markets. So wherever you sail, you can be sure of fast access to our service, spare parts and know-how.

Seldén, Furlex and SEL-Bus are registered trademarks of Seldén Mast AB.