

Power supply and SEL-Bus system

Parts, installation and troubleshooting

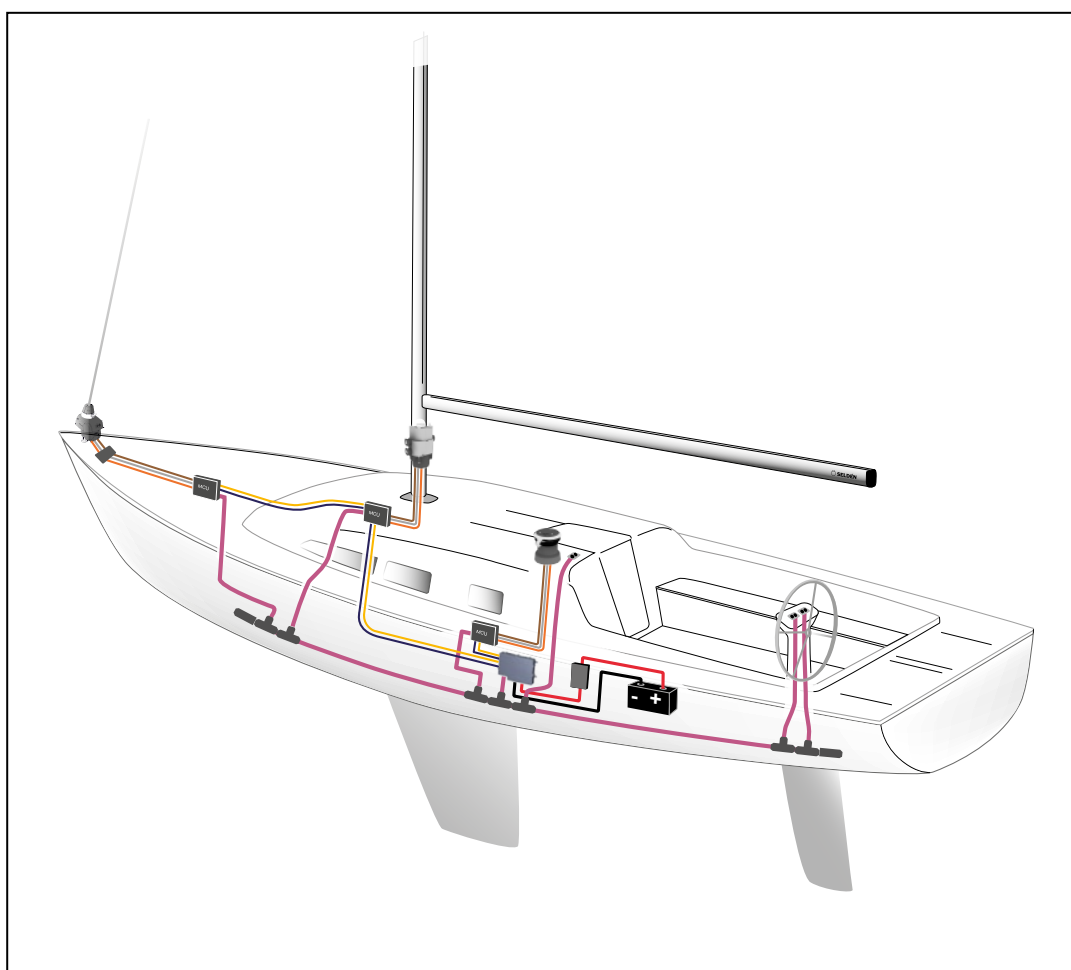

Introduction

This manual covers the installation and troubleshooting for installation of Seldén Power Supply and SEL-Bus system.

Please read the entire manual before installation and use of the product and keep it available for future references.

Safety Precautions

Follow and pay careful attention to instructions with the following symbols:



ATTENTION

This symbol indicates a critical moment in the assembly or technical advice.



WARNING

This symbol indicates a potentially hazardous situation. If not avoided, this could result in serious personal injury or damage to property.

To ensure a correct electrical installation

The key to a properly working and safe installation is to follow this manual to the point, and to select all components and cables correctly. Seldén's guideline for ordering required parts (part no 597-283-E) can be downloaded from www.seldenmast.com. If there are any questions about selecting the right products, please consult an authorized Seldén dealer. All dealers are listed on our website and divided in categories describing their competence. For electrical installation we recommend dealers in the category Advanced Technical Installations

Contents

1	Power supply & SEL-Bus system	4
1.1	Parts sold by Seldén	5
1.2	Parts not sold by Seldén	7
2	Installation	8
2.1	Preparing the installation.....	8
2.2	Installing the 12/24V cable main switch and fuse	9
2.3	Installing the PSU and MCU	10
2.4	Installing the push buttons... ..	13
2.5	SEL Bus system.....	14
2.6	Installing the SEL-Bus cable.....	15
2.7	Configuration of the control button to the SEL-Bus network	16
3	Operation	19
4	Troubleshooting	20
4.1	Network fuses	20
4.2	Fault codes	20
4.3	Fault codes on Power supply unit	21
4.4	Fault codes on Motor Control Unit	22
4.5	SEL-Bus converter and buttons inspection	22
4.6	SEL-Bus network error - component inspection	23
5	Technical information	24
6	Disposal	24
7	Warranty	24
	License information	25

1 Power supply & SEL-Bus system

Seldén's electrical power system can be connected to a voltage level between 10-30V and will deliver the required power up to 1000W.

The Power Supply Unit (PSU) amplifies the voltage to between 40-48V, just below the limit for high voltage regulation which is at 50V.

The electrical system is equipped with a diagnostic system, with error codes being presented by flashing LED's on the PSU and Motor Control Unit (MCU).

The PSU, MCU and control button(s) are connected through a Can Bus, referred to here as a SEL-Bus. The SEL-Bus system is used for communication between the units, enabling a diagnostic function and allowing the system to reduce power consumption by putting the system into sleep mode when not in use. During sleep mode there is a small amount of electrical consumption, making it important to switch off the main switch when not using the boat to avoid draining the battery.





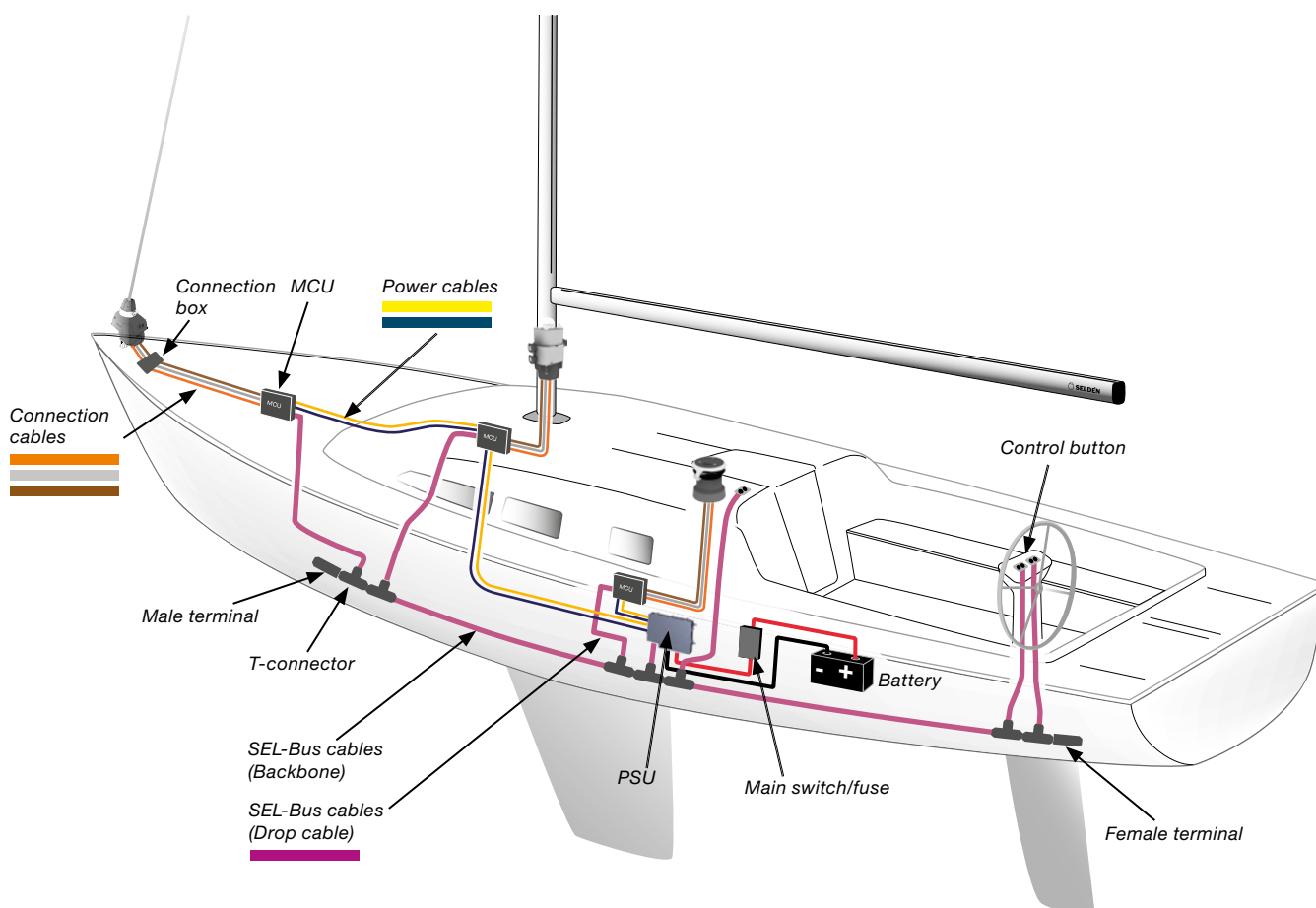



The SEL-Bus is a standalone system and shall not be connected to any other Can-bus system on the boat, for example the NMEA 2000



1.1 Parts sold by Seldén

All Power supply and SEL-Bus parts are sold separately in PSU Start pack and Drive unit Control Packs, listed in Seldén power supply and SEL-Bus system: Order guide 597-283-E.

General SEL-Bus network parts*		
Power supply unit (PSU)	Converts 12V or 24V to 42V 255x160x44 mm	
Input voltage	10-30 V	
Fuse (12V power supply to the PSU)	100 A (Fuse with time delay), 120-160 A (Fast acting fuse)	
Fuse (24V power supply to the PSU)	50 A (Fuse with time delay), 60-75 A (Fast acting fuse)	
Output voltage	42V	
Power consumption (sleep)	0,1 A per unit on the 42V circuit (at 12V) 0,05 A per unit on the 42V circuit (at 24V)	
Power consumption (maximum)	1000 W	
Efficiency	96%	
Weight	1100 g	
Female and male end terminal	Resistance in each end of the backbone	
T-connector	Connects drop cables to the backbone	
SEL-Bus cables	Backbone and drop cables 0,3m/1m/2m/5m/10m	
Main switch/fuse	100A/60A	
Power cables (PSU-MCU)	Yellow and Dark blue 6mm ² /10mm ²	

Drive unit specific parts*		
Motor Control Unit (MCU)	For various drive units 255x160x44 mm	
Input voltage	42 V	
Power consumption (sleep)	0,1 A per unit on the 42V circuit (at 12V) 0,05 A per unit on the 42V circuit (at 24V)	
Power consumption (maximum)	1000 W	
Efficiency	96%	
Weight	1700 g	
SEL-Bus converter	Converts push button signal to SEL-Bus network. Delivered with 4x1,5m (red/green) push button cables.	
Push buttons	In/Out 1/2	

*Actual product appearance may vary

1.2 Parts not sold by Seldén

Battery	12V or 24V battery, installed in the boat	
Power cables Battery – PSU	Use cable colour and standard for positive and negative cables in the boat.	

2 Installation

2.1 Preparing the installation

Mount the PSU and MCU, respectively, at a place and position in the boat which fulfills the following criteria:

- PSU is positioned close to battery.
- MCU is positioned close to its respective Seldén Motor Unit. Max allowed cable length of connection cables (grey, orange, brown) is 3x5m.
- PSU and MCU are positioned in a dry place.
- PSU and MCU are positioned so that the cable can form a drop loop. This is to prevent water ingress.

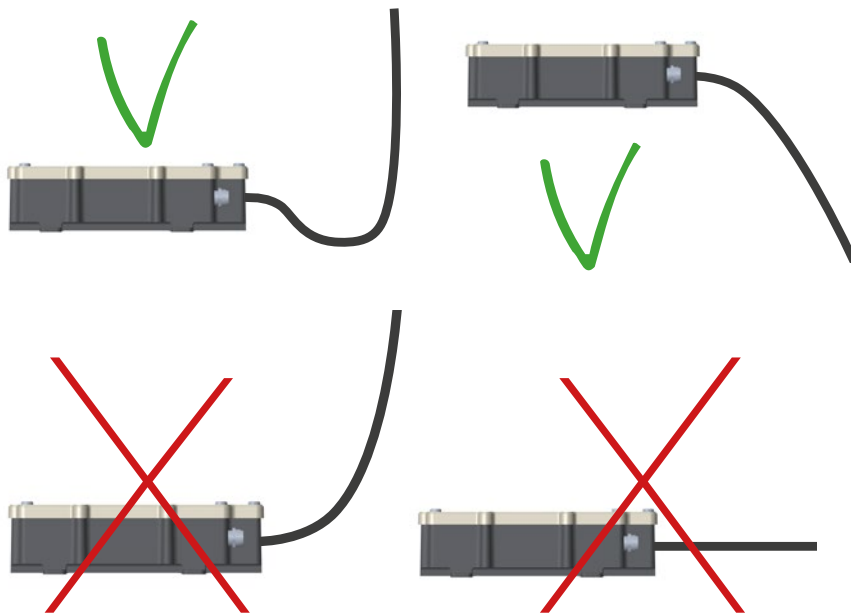

- The PSU and MCU need to be positioned so it will be possible to read any error codes from the LED indicator (see position of LED indicator in illustration to the right) and so that it is possible to read the unit's ID-label through the transparent lid.
- The PSU and MCU are positioned so that the fuses under the lid can easily be replaced.
- Have in mind that other systems that are already installed in your boat might be affected by the new electronic equipment. Do not install the PSU, MCU and wires close to devices that are sensitive to magnetic interference (e.g. compass, antenna, GPS-receiver).
- All components of the SEL-Bus system (T-connectors, terminals etc.) should be installed in an accessible position which enables inspection and replacement.

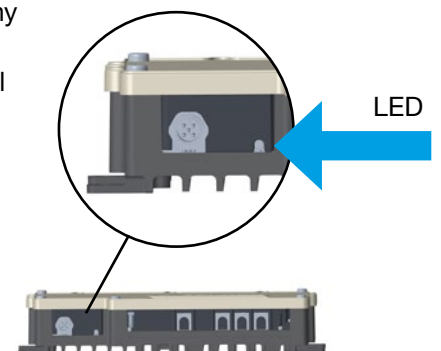

- ! Install the units in a dry place which prevents water ingress.
- ! Do not install the units in the engine compartment or in any other high temperature area.

2.2 Installing the 12/24V cable and main switch/fuse.

The main switch and fuse function should be installed between the battery and the PSU. If a custom switch/fuse option is used (other than the ones that are provided in Seldén Start pack for 12V and 24V) use one of the following two alternatives with fuse size listed in table below:

- High current integrated fuse switch
- High current switch and fuse

Battery system		
12V	100 A (Fuse with time delay)	120-160 A (Fast acting fuse)
24V	50 A (Fuse with time delay)	60-75 A (Fast acting fuse)

Install the switch/fuse and PSU to the battery using cables of the same quality and colours as standard in your boat. The required cable size depends on the battery voltage and the **total length of positive and negative cables** in the Battery/PSU-circuit. The cable sizes are listed in the table below:

Volt	Total length max 5 m	Total length 5-10 m
12V	Min cable area 25mm ²	Min cable area 35mm ²
24V	Min cable area 12mm ²	Min cable area 25mm ²



It is recommended to install a emergency stop to shut off the power to the SEL-Bus system. The emergency stop button should be placed for easy access when using the devices connected to the SEL-Bus system. Installation guid for the Seldén emergency stop is found in manual 597-219.



Turn off the battery switch before connecting the battery and PSU

Connect the 12/24 V circuit as outlined below.

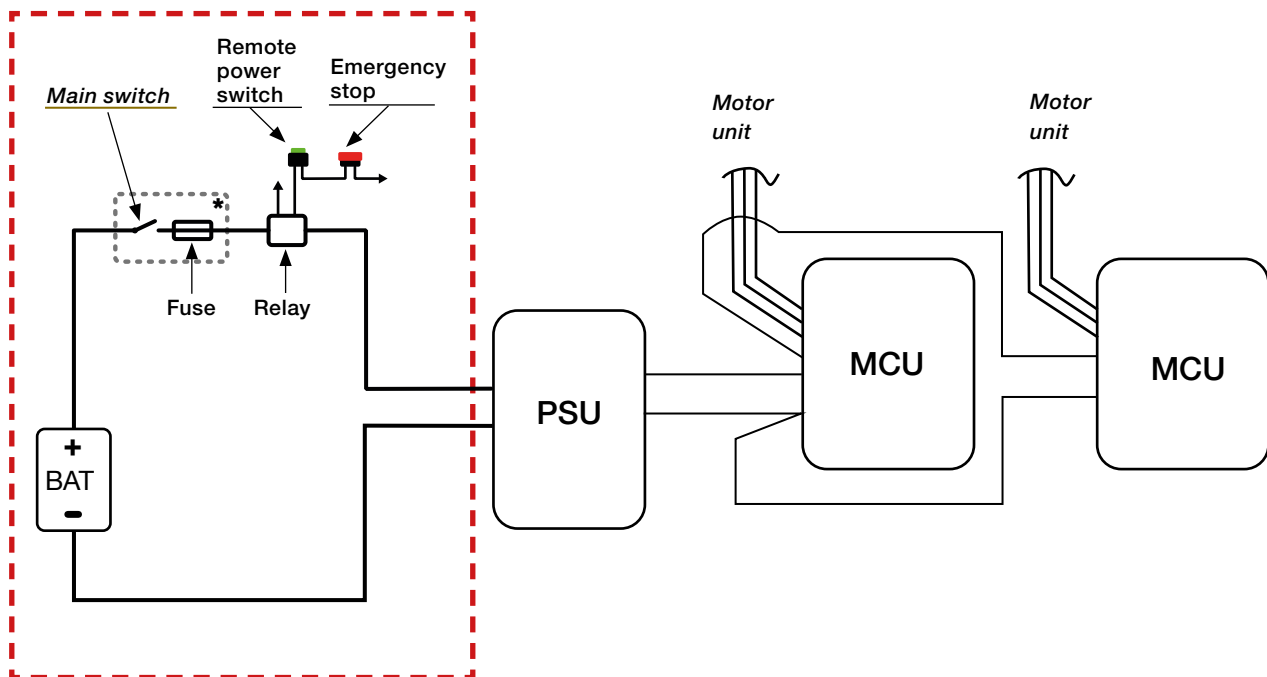

* Combined main switch and fuse is sold by Seldén

2.3 Installing the PSU and MCU



Turn off the battery switch before connecting the PSU and MCU.

Connect the MCU to the PSU using Seldén recommended colour coding:

Positive cable (connected to +VBUS): Dark blue

Negative cable (connected to -VBUS): Yellow

For the required cable area between the PSU and MCU, use a cable dimension corresponding to table below (calculate as the **sum of positive and negative cable lengths**):

Cable dimension (cross sectional area)	Recommended max length (positive and negative cable)
6mm ²	18m
10mm ²	40m

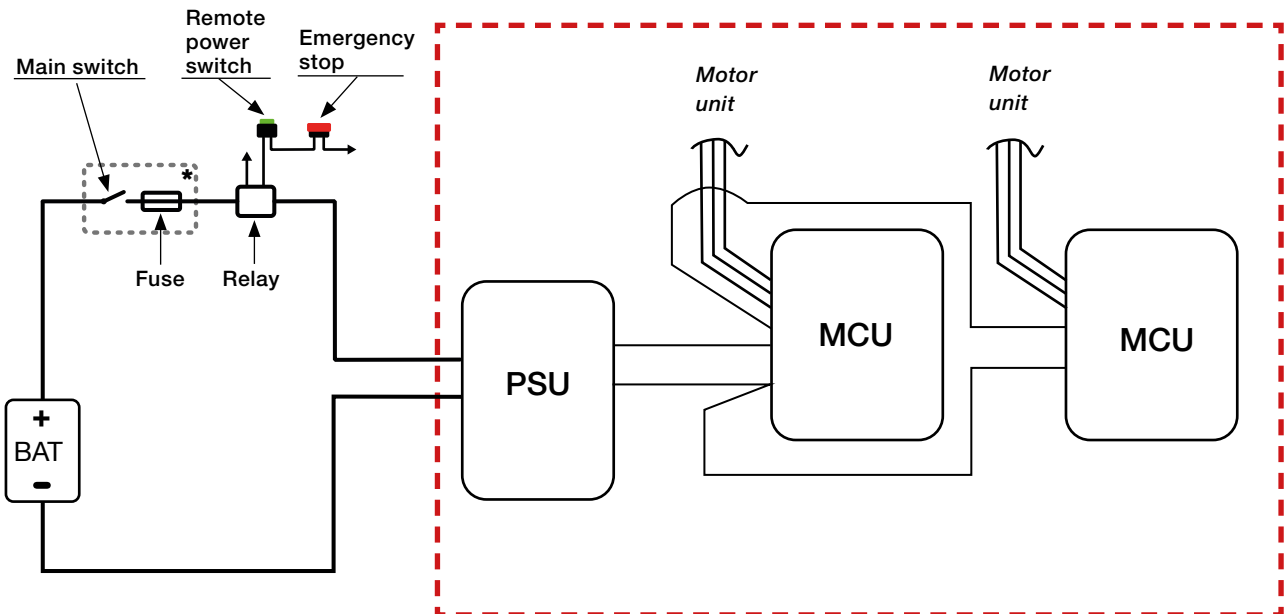

If multiple Motor Control Units are used, the additional MCUs can be connected in parallel either directly to the PSU or via another MCU. The different wiring options may require different cable lengths and cable sizes. **Example** of calculation of required power cable size for systems with multiple motor control units:

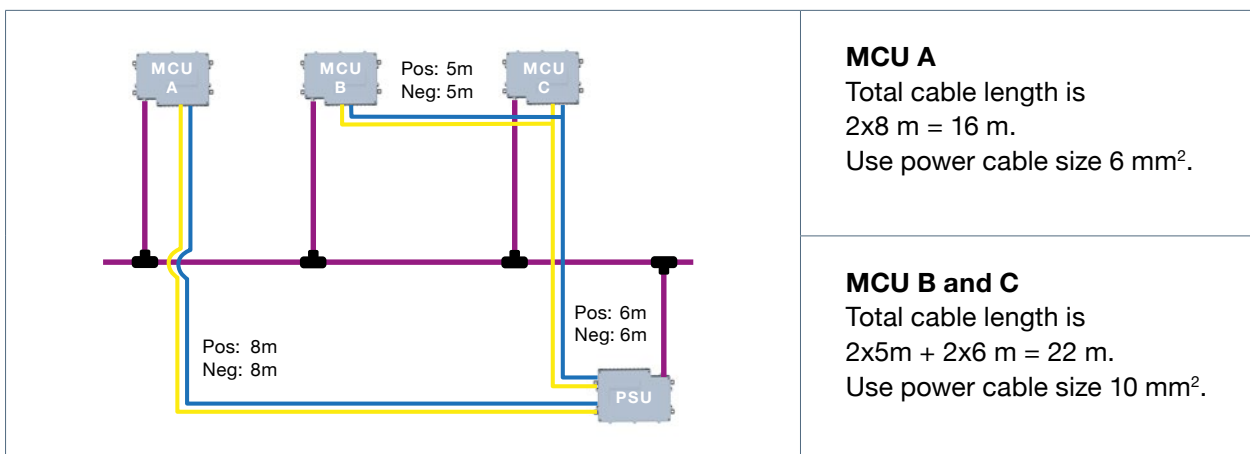

PSU wiring

1.

Unscrew the 5 Torx head screws (T20) of the PSU lid, highlighted in the image to the right.

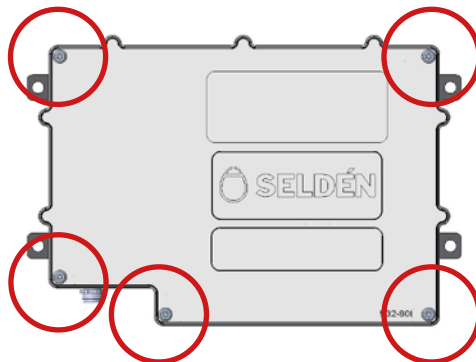

2.

Remove the lid to uncover the connectors.

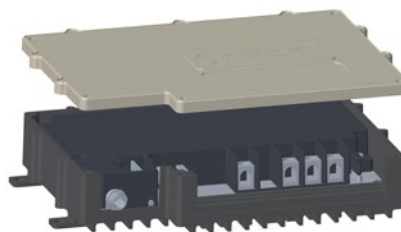

3.

Install the cable from the positive terminal on the battery, to the connector marked +BAT. Fasten the cable.

4.

Install the cable from the negative battery terminal to the connector marked -BAT and fasten the cable.

Use cable colour as standard in the boat.

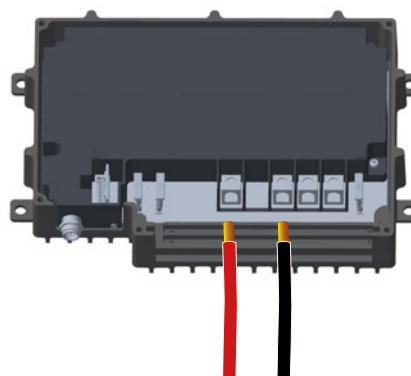

5.

Install the dark blue cable from +VBUS on the PSU to +VBUS on the MCU.

6.

Install the yellow cable from -VBUS on the PSU to -VBUS on the MCU.

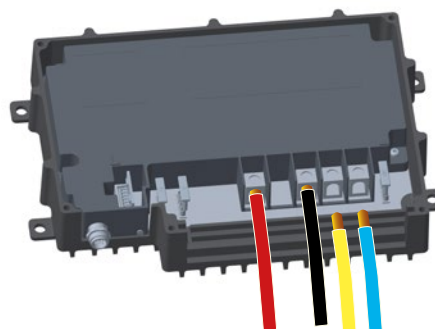

MCU wiring

1.

Unscrew the Torx head screws (T20) to open the lid of the MCU units in the same way as on the PSU.

2.

Connect the positive dark blue cable from the PSU to the connector marked +VBUS and the negative yellow cable to -VBUS. Fasten both connections.

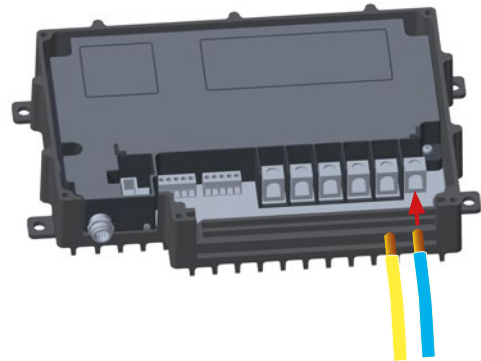

3.

To install more MCU's, connect in parallel to either the PSU or MCU, to get the easiest wiring.

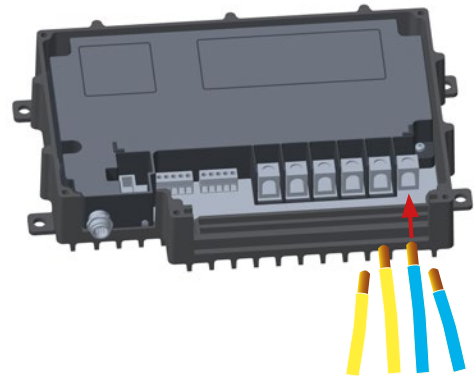

4.

Finally, connect the connection cables from the Seldén Motor Unit to their respective connector (L3, L2, L1) of the MCU.



Note that the position of connection cables may vary between different motor units. Carefully follow the label or pairing instructions in each respective drive unit manual.

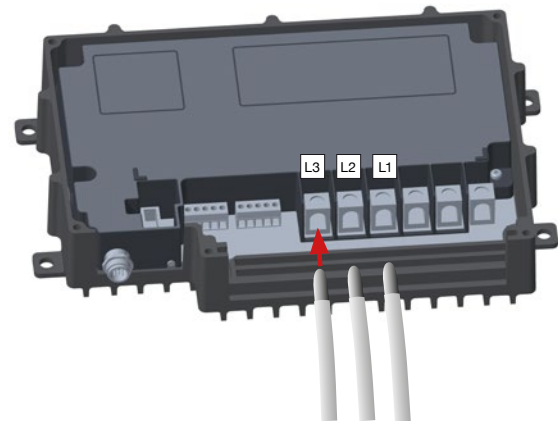

2.4 Installing the push buttons

A SEL-Bus converter is used to convert signals from the push buttons to the SEL-Bus system CAN protocol.

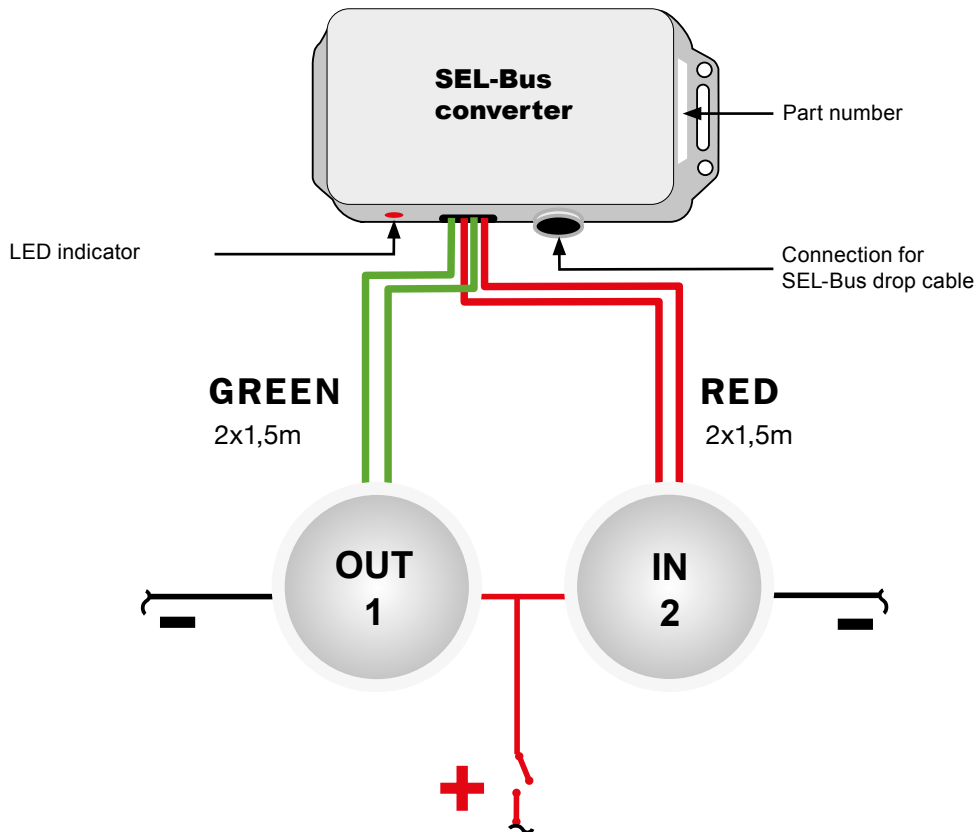

The push buttons need to be connected to the correct SEL-Bus converter:

Furlex, Winch, CXe = 532-827-01

Furling mast = 532-827-02

1. Find an appropriate position for the SEL-Bus Converter; close to buttons and protected from the weather and so the LED indicator is visible during inspection.
2. Cut the green and red cables included in the SEL-Bus converter to the appropriate length. Attach the press cable connectors included in the Push button kit.
3. Connect the green cables to "out"/"first speed" button, using the correct terminal positions as described in respective push button instruction.
4. Connect the red cables to "in"/"second speed" button, using the correct terminal positions as described in respective push button instruction.
- (5.) Back lightning, which is optional, is connected to terminal positions as described in respective push button instruction. The lighting is preferably connected to the nav-lights switch. Use the colour coding and cables as standard in your boat.
6. Install the push buttons. Hole dimensions are found in each respective push button instruction.



Place and orientate the push buttons so that risk of unintentional activation (e.g. from standing/sitting) is low.

2.5 SEL-Bus system

! Keep the battery switch turned off until all SEL-Bus cables are installed

The SEL-Bus network communicates between the PSU, MCU and control buttons, and provides these units with information. The network uses a “backbone” as a main communication cable that is routed along the boat and “drop cables” to connect the PSU, MCU and control buttons. The SEL-Bus network works in series, which allows the network to be easily expanded.

The SEL-Bus system

T-connector (A): A three-way connector with 1 male and 2 female connectors. The T-connectors are used to connect drop cables from the unit(s) to the backbone.

Male (B1) and female terminal (B2): A 120-ohm resistor at each end of the SEL-Bus backbone. The terminals are essential for a secure signal.

Backbone (C): The main communication cable. Must start and end with end terminal B1 and B2.

Units (D): Any system connected to the SEL-Bus via a drop cable. These units are the PSU, MCU and control button(s).

Drop cable (E): The cable connecting a Unit to the backbone. Max. length of 5 m.

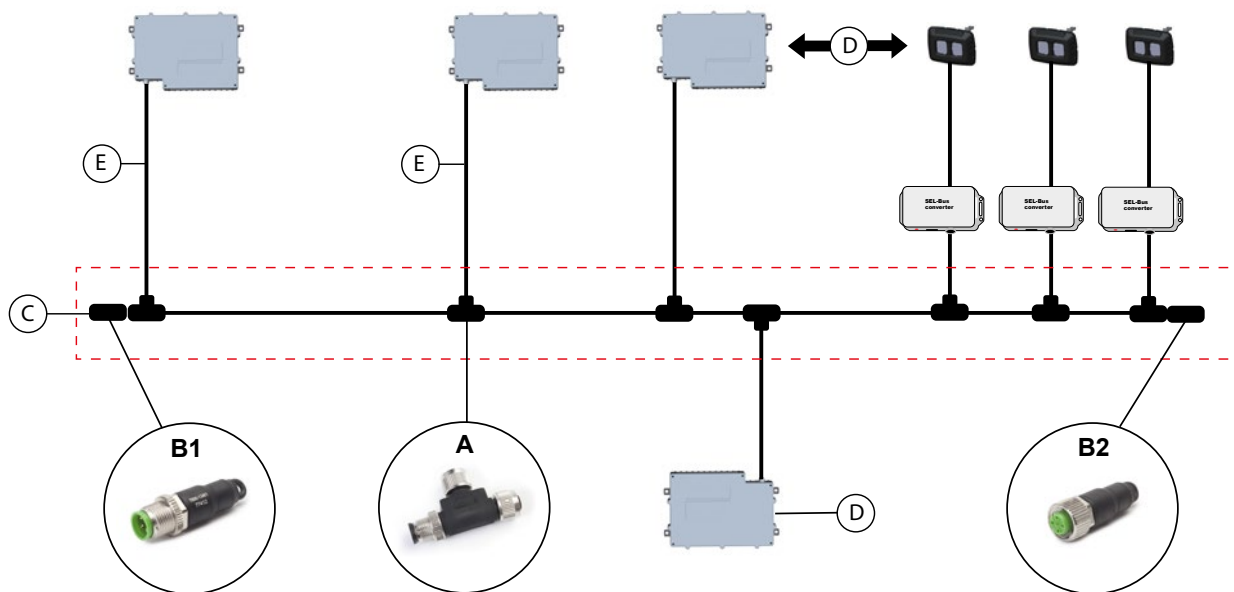

! The total length of the SEL-Bus network (backbone + drop cables) must not exceed 70m.

! An existing SEL-Bus system can easily be expanded with additional units at any time.

2.6 Installing the SEL-Bus cable

1. Start at one end of the backbone. Connect the male terminal to the T-connector.
2. Connect the drop cable from the first unit to the T-connector.
3. Connect the first backbone cable to the T-connector.
4. Connect a new T-connector to the end of the first backbone cable.
5. Repeat step 3-5 for every additional unit (PSU, MCU, control buttons) to be connected to the backbone.
6. Finish by connecting the female terminal to the end of the backbone.

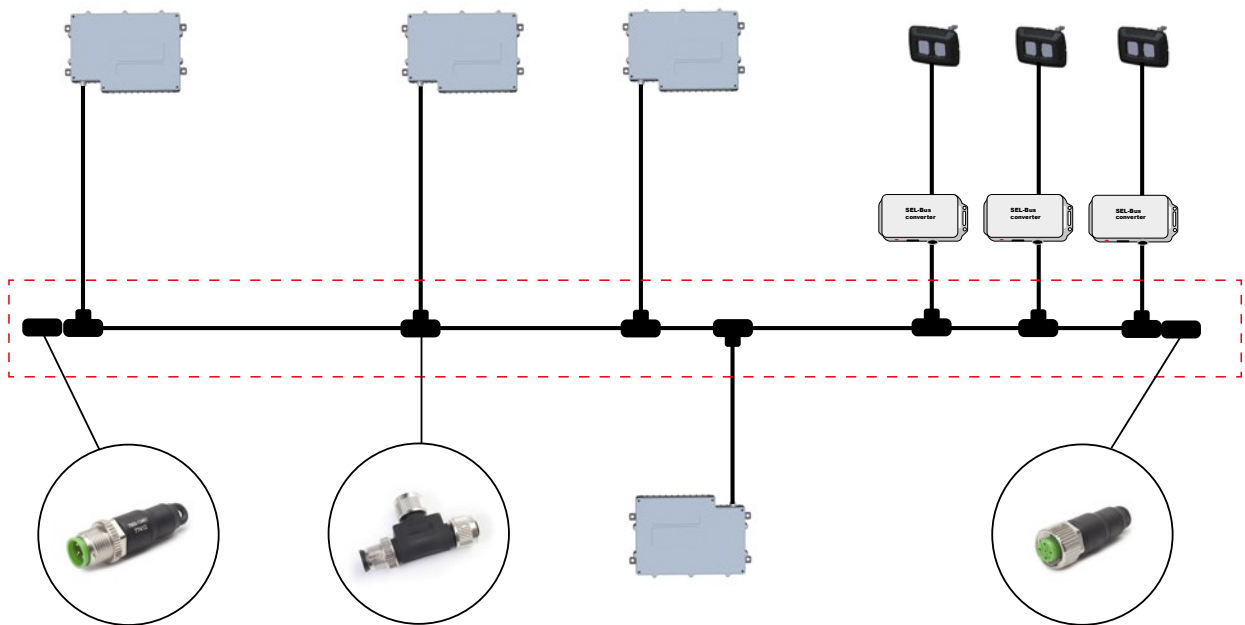

T-connectors can be connected directly to each other.



SEL-Bus cables can be connected directly to each other. Example: 2x 5m SEL-Bus cable can be used as 1x 10m.

2.7 Configuration of the control button to the SEL-Bus network.

To configure the control buttons to the SEL-Bus network, the configuration button on each respective MCU is used. The configuration button is located under the transparent lid, behind the LED and next to the control chip.

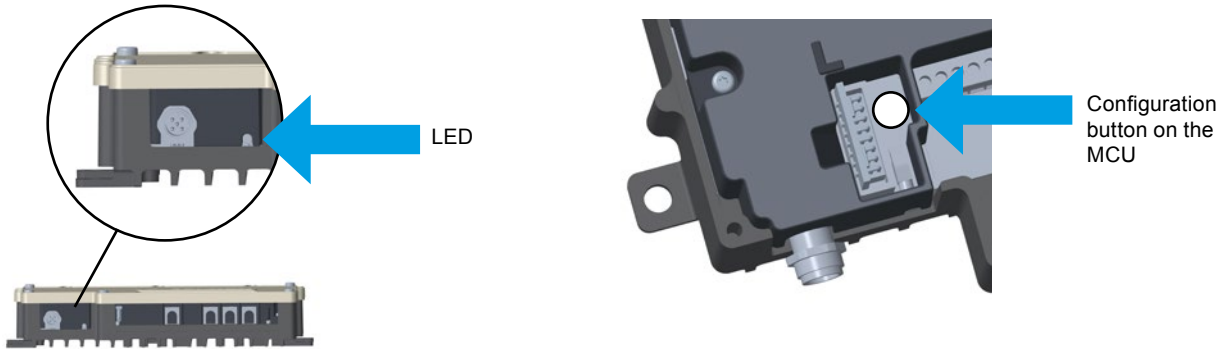

! Use a non-metal pin to depress the configuration button.

! MCU must be connected to motor unit (chapter 2.3) before control buttons can be configured.

Config. Button	Mode	LED Indication	Action
Press one time	Button configuration mode	Violet	Press primary set of control button to link it to the MCU.
Press one time after first configuration.	Button configuration mode +	Violet	Add set of buttons to the same MCU (e.g. auxiliary control buttons B)
Press two times	Reset configuration memory	Violet then green	Erases earlier configurations. No button sets are now linked.

Primary buttons

Repeat for each Motor unit (with respective MCU and control button set)

<p>1. Turn the main switch on and wait until the LED on the PSU and MCU turn green.</p>	
<p>2. Push the configuration button on the MCU, the LED will turn violet.</p>	
<p>3. Push and hold either one of the two buttons in the control button set (in/out or 1/2) for approximately 5 seconds until the motor unit generates a start-up signal. Buttons are now ready to use.</p>	

Auxiliary buttons

It is possible to add a second set of control buttons to the same motor unit, to enable control from various positions. This can be done in two ways:

A

One SEL-Bus converter.

The two button sets are connected in parallel to the same SEL-Bus converter (spliced cables).

Any of the buttons can be pressed during the primary configuration, and all buttons connected to the same SEL-Bus converter will be configured to the MCU at the same time.

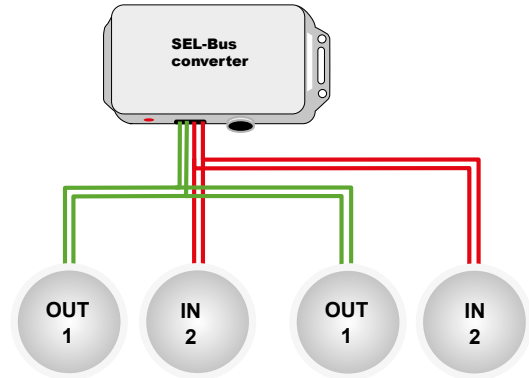

B

Two separate SEL-Bus converters.

The auxiliary buttons are installed and connected to the SEL-Bus network via a SEL-Bus cable in the same way as the primary set.

After the first control button set is configured, press the configuration button on the MCU one more time and press the auxiliary button set until the motor unit once again generates a start-up signal.

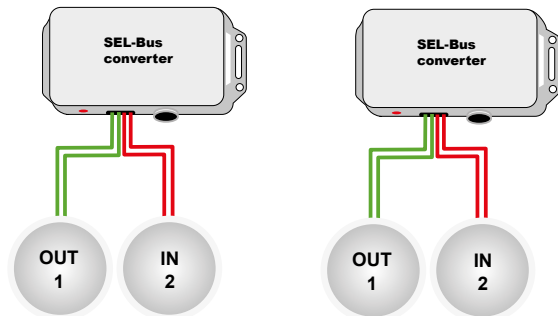

Remote control of motorized sailing equipment can be hazardous and require full attention on the motorized unit while in use.



Synchronized Main Furling

To configure the control buttons (winch and main) to electric furling mast with synchronized outhaul, the configuration should be done in the following order.

Remember to reset the configuration memory if the MCU have been configured to control buttons before.

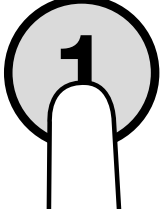

It is recommended to disengage the motor unit from the manual furling gear (using the clutch) during configuration.

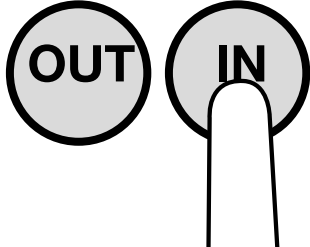
<p>A Configure winch MCU to winch buttons</p>	<p>Press the configuration button on Winch MCU.</p> <p>Push and hold winch button 1 or 2 until the winch generate the start-up signal.</p> 
<p>B Configure winch MCU to the MAIN OUT button (for synchronized outhaul)</p>	<p>Press the configuration button on Winch MCU.</p> <p>Push and hold MAIN OUT until the winch generates the start-up signal.</p> 
<p>C Configure furling mast MCU to the MAIN IN button</p>	<p>Press the configuration button on Furling mast MCU</p> <p>Push and hold IN until the mast motor generates the start-up signal.</p> 

3 Operation

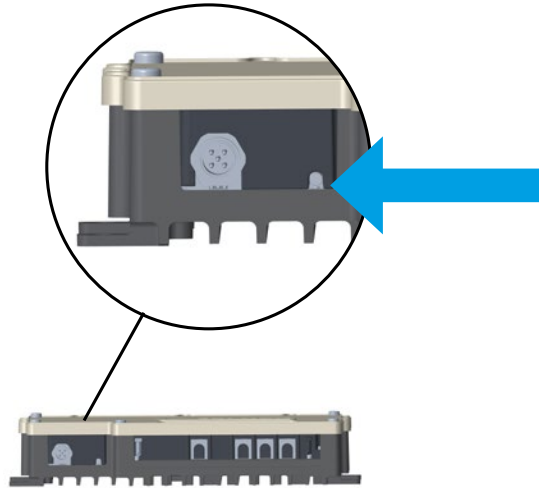

The PSU and MCU have a LED that indicate the status of the system.

When the main switch is turned on, the LED turns blue which indicates the PSU and MCU are active and running a start diagnosis. After 5-15 sec the LED changes to green which indicates that the system is working normally and is set to energy saving stand-by mode.

When a control button is pushed and a motor unit is running, the system is activated and the LED turns blue. The LED turns green again after 5-15 sec.

MCU status codes (steady LED colour state)

Indication	Status
Green	Stand-by mode
Blue	Active mode
Violet	Control button SEL-Bus configure mode
Yellow	Start-up calibration

PSU status codes (steady LED colour state)

Indication	Status
Green	Stand-by mode
Blue	Active mode

 Always turn off the system when not in use.

4 Troubleshooting

4.1 Network fuses

The Power supply unit and each Motor Control Unit have fuses installed under the plastic lid. Use standard blade fuses of correct current rating if they need to be changed.

Power supply unit

3A/5A: Fuses for the SEL-Bus network. Blown fuses will cause communication failure on network.

30A: Power input fuse. Blown fuse will show a green LED indicator on PSU while the other units on the network will be dead (no LED light).

Motor Control Unit

30A: Power input fuse. Blown fuse will cause the MCU to be dead (no LED light). The other units in the network will work normally.

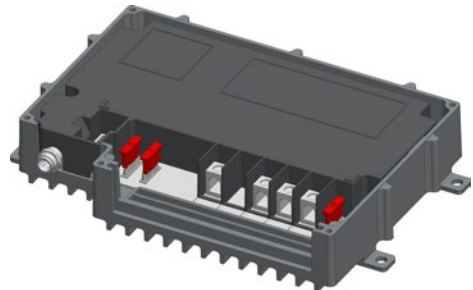

4.2 Fault codes

If the system experiences an error, it will display this via the LED located next to SEL-Bus output on both the PSU and the MCU. If the system has recently been started it can take up to a minute for the system to start indicating fault codes.

The power supply and the control unit each have their own set of fault codes. The codes are divided into two different categories, warning codes and error codes. The system will continue to indicate fault codes until turned off. If multiple faults are detected the system will indicate these after each other.

Warning codes (flashing white)

The LED will indicate the warning codes by flashing white.

Error codes (flashing in alternating colours)

Error codes indicate a more serious problem with the system, such as a hardware fault. The system will indicate these by alternating the colour of the LED.

If, for example, the PSU cannot find any Motor Control Units on the SEL-Bus network, the PSU will identify this as a SEL-Bus cable/network error. The LED of the PSU will flash two times before briefly pausing and repeating the sequence, indicating warning code number 2. If another fault is detected, e.g. memory chip error, the LED will first flash two times in white, pause, then flash red-white-green before pausing and repeating the sequence again.

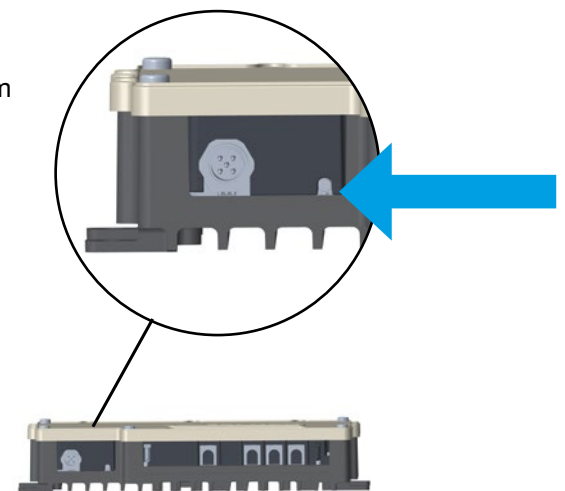

 Write down the code before you shut down the system, as the code will not be memorized.

 Fault codes and troubleshooting are continuously updated. For latest version, please visit www.seldenmast.com

4.3 Fault Codes on Power Supply Unit

Flashing white sequence	Code definition	Action
1	Output current overload or output over/under voltage	<i>Information for service technician</i>
2	SEL-Bus cable/network error	a. Check 3A and 5A fuse on PSU, change if blown. b. See chapter 4.6
3	Device overheat	a. PSU is installed in a too hot place (e.g. close to an engine). Relocate PSU. b. Extreme heavy operation. Let cool.
4	Cable voltage drop between PSU and MCU (Warning)	a. Control that power cables have sufficient dimension (see chapter 2.3.) Rewire if necessary. b. Control if any power cables are damaged or poorly connected to unit. Rewire if necessary.
5	Cable voltage drop between PSU and MCU (Error). System turned off due to fire hazard.	See code 4 above
6	Input over current limiter activated	Change PSU
7	Input over voltage	Troubleshoot general electric system in boat.
8	Input under voltage	a. Bad battery, change. b. Control 12V/24V power cable size (see chapter 2.2). Rewire if necessary. c. Control if battery cables are damaged or poorly connected to PSU. Rewire if necessary.

Error colour combination	Code definition	Action
Red, white, red	General electrical hardware error	PSU need to be exchanged.
Red, white, green	Memory chip error	Memory chip needs to be exchanged.
Red, yellow, red	MCU Memory chip inserted in PSU	Insert correct PSU chip.
Red, yellow, green	SEL-Bus hardware error	PSU needs to be exchanged.
Red, yellow, blue	Multiple PSU detected	Only one PSU is needed/allowed per SEL-Bus system.

4.4 Fault Codes on Motor Control Unit

Flashing white sequence	Code definition	Action
1	Force derivate lockout triggered	<i>Information for service technician</i>
2	SEL-Bus cable/network error	a. Check 3A and 5A fuse on PSU, change if necessary. b. See chapter 4.6
3	Device overheated	a. MCU is installed in a too hot place (close to engine etc.). Relocate MCU. b. Extreme heavy operation. Let cool.
4	SEL-Bus network communication failure	a. Check 3A and 5A fuse on PSU, change if necessary. b. See chapter 4.6
5	PSU power failure	Check fault code on PSU.
7	SEL-Bus converter error	See chapter 4.6

Error colour combination	Code definition	Action
Red, white, red	General electrical hardware error	MCU needs to be exchanged.
Red, white, yellow	Bad motor or connection to motor	a. Control if any of the connection cables are damaged or poorly connected to MCU. Rewire if necessary. b. Bad drive unit, change.
Red, white, green	Memory chip error	Memory chip needs to be exchanged
Red, yellow, red	PSU Memory chip inserted in MCU	Insert correct MCU chip
Red, yellow, green	SEL-Bus hardware error	MCU needs to be exchanged.
Red, yellow, blue	PSU error	PSU needs to be exchanged.
Red, flashing	Memory chip missing or faulty	Install / Replace Memory chip

4.5 SEL-Bus converter and buttons inspection.

The red LED indicator on the SEL-Bus Converter indicates that the converter is working properly and is installed to the SEL-Bus network. The indicator will light 5 min after the system is turned on and 5 min after each time any of its respective buttons have been activated.

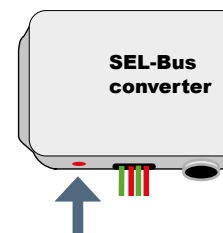

Trouble shooting for non-working control buttons:

LED indicator	Possible Cause	Action	LED
LED indicator is on	Buttons are not configured to MCU	Configure buttons according to section 2.7	
	Bad connection between SEL-Bus converter and MCU.	Check fault codes on corresponding MCU (section 4.4) and combined fault codes for network component inspection (section 4.6).	
	Bad connection between button and SEL-Bus converter.	Keep system power on. Wait for LED to go out (5 min). Push control button. If LED stays out, connection between converter and button is bad. Check cables, connections and if fault persists change push buttons.	
LED indicator is flashing 2, 4 or 5 times	SEL-Bus converter software or hardware error	Replace the SEL-Bus converter	
LED indicator is flashing 3 times	Button error	Check the cable connections to the buttons, make sure the connectors are clean. Replace the buttons.	
LED indicator is off	Bad connection between SEL-Bus converter and SEL-Bus network. (No power)	Check combined fault codes for network component inspection (section 4.6).	
	Bad SEL-bus converter	Change SEL-Bus converter.	

4.6 SEL-Bus network error - component inspection

Read the fault codes on every unit (PSU, MCUs and SEL-Bus converters) connected to the SEL-Bus network. By combining the fault codes on all units, it will be easier to locate where on the SEL-Bus network the problem is. Turn off and on the system one time before starting this trouble shooting. Remember that LED indicator on SEL-Bus converter turns off after 5 minutes of inactivation.

Following is a guide of where in the SEL-Bus network to find the possible failure (“X”). Failure can be caused by defective SEL-Bus cable/cable contacts or defective adjacent T-connectors. Ensure that the contacts are properly connected and exchange components if necessary.

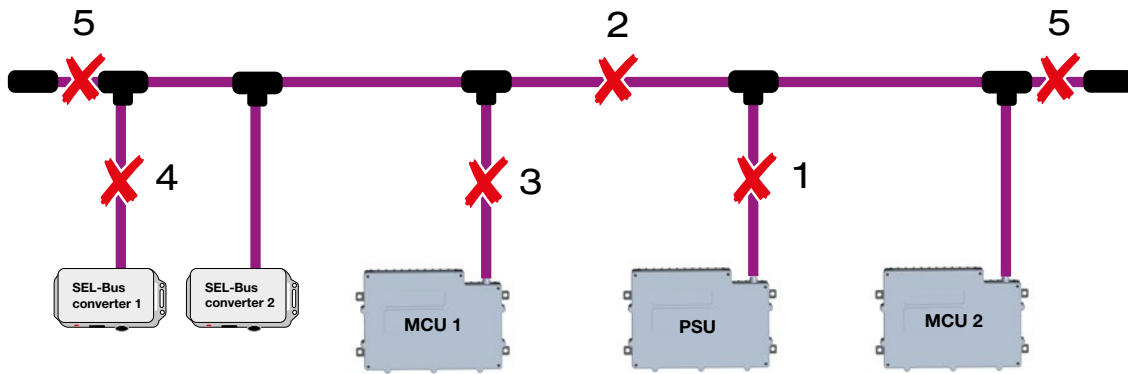

Example 1: Control buttons are configured.

X	SEL-Bus converter 1	SEL-Bus converter 2	MCU 1	PSU	MCU 2	Comment
	Red	Red	Green	Green	Green	Normal mode
1	-	-	2 white 7 white	2 white	2 white 7 white	Bad connection between PSU and Backbone. No power to any unit.
2	-	-	2 white 7 white	Green	7 white	MCU 1 has no power and no contact with SEL-Bus converter 1. MCU 2 has power but have lost contact to SEL-Bus converter 2.
3	Red	Red	2 white 7 white	Green	Green	MCU 1 has no power or contact with paired SEL-Bus converter.
4	-	Red	7 white	Green	Green	SEL-Bus converter 1 has lost connection to backbone and cannot communicate with MCU 1.
5	-	-	2 white 4 white	2 white	2 white 4 white	End terminals are defective/incorrect position/bad contact. Bad communication between all units. Alternative cause is broken 3A, 5A fuse on PSU.

Example 2: Control buttons have not yet been configured (first time installation).

X	SEL-Bus converter 1	SEL-Bus converter 2	MCU 1	PSU	MCU 2	Comment
	Red	Red	Green	Green	Green	Normal mode. As the control buttons are not configured, they will not activate any unit.
1	-	-	2 white	2 white	2 white	Bad connection between PSU and Backbone. No power to any unit.
2	-	-	2 white	Green	Green	MCU 1 has no power. SEL-Bus converters have no power. Contact between MCU and SEL-Bus converters are unknown as they are not configured.
3	Red	Red	2 white	Green	Green	MCU 1 has no power.
4	-	Red	Green	Green	Green	SEL-Bus converter 1 has no power.

5 Technical information

The Seldén Power Supply and SEL-Bus system, which has been tested according to standard EN 61800-3, meets the EMC directive 2014/30/EU. This product has also been tested according to standard EN 60945 and meets the limits of emissions for maritime equipment when in standby mode.

6 Disposal

The crossed out wheeled bin symbol on the products means that used electrical and electronic equipment (WEEE) should not be mixed with general household waste.

For proper treatment, recovery and recycling, please take this product(s) to designated collection points where it will be accepted free of charge. Alternatively, in some countries, you may be able to return your products to your local retailer upon purchase of an equivalent new product.

Disposing of this product correctly will help save valuable resources and prevent any potential negative effects on human health and the environment, which could otherwise arise from inappropriate waste handling.

Please contact your local authority for further details of your nearest designated collection point.

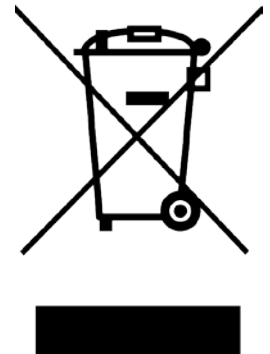

7 Warranty

Seldén Mast AB guarantees Seldén Power Supply and SEL-Bus system for 2 years. The guarantee covers faults arising from defective design, materials or workmanship.

The guarantee is only valid if the product is assembled, operated and maintained in accordance with this manual and is not subjected to loads in excess of those indicated in the brochure and on the Seldén website.

Complete shipment and warranty conditions are to be found on Seldén's website www.seldenmast.com. See Resources/Partners information/General information/General conditions of sale (595-546-E).

If the system is repaired or modified by anyone other than Seldén Mast AB or one of our authorized dealers, the guarantee ceases to be valid.

Seldén Mast AB reserves the right to alter the content and design without prior warning.

License information

Parts of the device firmware build on open-source software. Those that require reproduction of license text are given below.

Copyright 2012.Texas Instruments Incorporated

All rights reserved

Redistribution and use in source and binary forms, with or without modification, are permitted provided that the following conditions are met:

1. Redistributions of source code must retain the above copyright notice, this list of conditions and the following disclaimer.
2. Redistributions in binary form must reproduce the above copyright notice, this list of conditions and the following disclaimer in the documentation and/or other materials provided with the distribution.
3. Neither the name of the copyright holder nor the names of its contributors may be used to endorse or promote products derived from INDIRECT, INCIDENTAL, SPECIAL, EXEMPLARY, OR CONSEQUENTIAL DAMAGES (INCLUDING, BUT NOT LIMITED TO, PROCUREMENT OF SUBSTITUTE GOODS OR SERVICES; LOSS OF USE, DATA, OR PROFITS; OR BUSINESS INTERRUPTION) HOWEVER CAUSED AND ON ANY THEORY OF LIABILITY, WHETHER IN CONTRACT, STRICT LIABILITY, OR TORT (INCLUDING NEGLIGENCE OR OTHERWISE) ARISING IN ANY WAY OUT OF THE USE OF THIS SOFTWARE, EVEN IF ADVISED OF THE POSSIBILITY OF SUCH DAMAGE this software without specific prior written permission.

THIS SOFTWARE IS PROVIDED BY THE COPYRIGHT HOLDERS AND CONTRIBUTORS "AS IS" AND ANY EXPRESS OR IMPLIED WARRANTIES, INCLUDING, BUT NOT LIMITED TO, THE IMPLIED WARRANTIES OF MERCHANTABILITY AND FITNESS FOR A PARTICULAR PURPOSE ARE DISCLAIMED. IN NO EVENT SHALL THE COPYRIGHT HOLDER OR CONTRIBUTORS BE LIABLE FOR ANY DIRECT,

Copyright 2007, Nick Galbreath -- nickg [at] modp [dot] com

Redistribution and use in source and binary forms, with or without modification, are permitted provided that the following conditions are met:

1. Redistributions of source code must retain the above copyright notice, this list of conditions and the following disclaimer.
2. Redistributions in binary form must reproduce the above copyright notice, this list of conditions and the following disclaimer in the documentation and/or other materials provided with the distribution.
3. Neither the name of the copyright holder nor the names of its contributors may be used to endorse or promote products derived from this software without specific prior written permission.

THIS SOFTWARE IS PROVIDED BY THE COPYRIGHT HOLDERS AND CONTRIBUTORS "AS IS" AND ANY EXPRESS OR IMPLIED WARRANTIES, INCLUDING, BUT NOT LIMITED TO, THE IMPLIED WARRANTIES OF MERCHANTABILITY AND FITNESS FOR A PARTICULAR PURPOSE ARE DISCLAIMED. IN NO EVENT SHALL THE COPYRIGHT HOLDER OR CONTRIBUTORS BE LIABLE FOR ANY DIRECT, INDIRECT, INCIDENTAL, SPECIAL, EXEMPLARY, OR CONSEQUENTIAL DAMAGES (INCLUDING, BUT NOT LIMITED TO, PROCUREMENT OF SUBSTITUTE GOODS OR SERVICES; LOSS OF USE, DATA, OR PROFITS; OR BUSINESS INTERRUPTION) HOWEVER CAUSED AND ON ANY THEORY OF LIABILITY, WHETHER IN CONTRACT, STRICT LIABILITY, OR TORT (INCLUDING NEGLIGENCE OR OTHERWISE) ARISING IN ANY WAY OUT OF THE USE OF THIS SOFTWARE, EVEN IF ADVISED OF THE POSSIBILITY OF SUCH DAMAGE

Copyright (c) 2006-2015, Thomas Pircher <tehpeh-web@tty1.net>

Permission is hereby granted, free of charge, to any person obtaining a copy of this software and associated documentation files (the "Software"), to deal in the Software without restriction, including without limitation the rights to use, copy, modify, merge, publish, distribute, sublicense, and/or sell copies of the Software, and to permit persons to whom the Software is furnished to do so, subject to the following conditions:

The above copyright notice and this permission notice shall be included in all copies or substantial portions of the Software.

THE SOFTWARE IS PROVIDED "AS IS", WITHOUT WARRANTY OF ANY KIND, EXPRESS OR IMPLIED, INCLUDING BUT NOT LIMITED TO THE WARRANTIES OF MERCHANTABILITY, FITNESS FOR A PARTICULAR PURPOSE AND NONINFRINGEMENT. IN NO EVENT SHALL THE AUTHORS OR COPYRIGHT HOLDERS BE LIABLE FOR ANY CLAIM, DAMAGES OR OTHER LIABILITY, WHETHER IN AN ACTION OF CONTRACT, TORT OR OTHERWISE, ARISING FROM, OUT OF OR IN CONNECTION WITH THE SOFTWARE OR THE USE OR OTHER DEALINGS IN THE SOFTWARE.

DINGHIES KEELBOATS YACHTS

*Seldén Mast AB, Sweden
Tel +46 (0)31 69 69 00
e-mail info@seldenmast.com*

*Seldén Mast Limited, UK
Tel +44 (0) 1329 504000
e-mail info@seldenmast.co.uk*

*Seldén Mast Inc., USA
Tel +1 843-760-6278
e-mail info@seldenus.com*

*Seldén Mast A/S, DK
Tel +45 39 18 44 00
e-mail info@seldenmast.dk*

*Seldén Mid Europe B.V., NL
Tel +31 (0) 111-698 120
e-mail info@seldenmast.nl*

*Seldén Mast SAS, FR
Tel +33 (0) 251 362 110
e-mail info@seldenmast.fr*

www.seldenmast.com

Dealer:

The Seldén Group is the world's leading manufacturer of masts and rigging systems in carbon and aluminium for dinghies, keelboats and yachts. The Group consists of Seldén Mast AB in Sweden, Seldén Mast A/S in Denmark, Seldén Mast Ltd in the UK, Seldén Mid Europe B.V. in the Netherlands, Seldén Mast Inc in the USA and Seldén Mast in France. Our well known brands are Seldén and Furlex. The worldwide success of Furlex has enabled us to build a network of over 750 authorised dealers covering the world's marine markets. So wherever you sail, you can be sure of fast access to our service, spare parts and know-how.



www.seldenmast.com