

# 8 Furling system CX & GX

## 8.1 Seldén CX, Furling system for Code 0 and stay sail

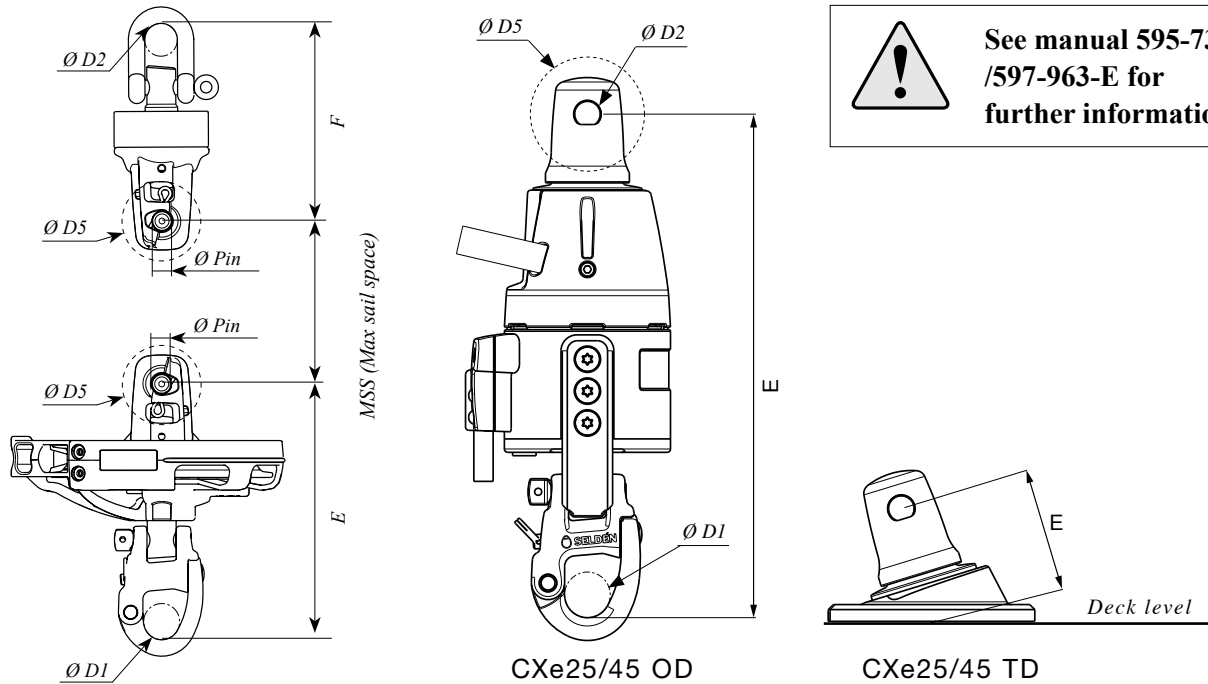

System	Maximum sail space (Measurement calculated from halyard shackle to fastening device on boat/bow sprit)			D1 mm	D2 mm	Ø Pin mm	Max fork space Ø D5 mm
	E mm	F mm	F+E mm				
CX10	115	90	205	14	12	10	40
CX15	125	95	220	16	12	10	40
CX25	155	120	275	22	20	12	45
CX40	190	145	335	24	24	16	55
CX45	190	145	335	24	24	16	66
CXe25 OD	285	120	405	22	20	12	64
CXe25 TD	70	120	190	-	20	12	64
CXe45 OD	300	145	445	24	24	16	68
CXe45 TD	70	145	215	-	24	16	68

### Thimbles for AT-cables & AT-lines

System	Part no.	Ø Hole mm	D3 Max Ø AT-cable mm	W1 mm	H1 mm	H3 mm <sup>1)</sup>
CX10/15	545-114	10.3	9	16	45	18
CX10/15	545-116	10.3	11	16	45	18
CX/CXe25	545-216	12.3	13	19	56	21
CX40&CX/CXe45	545-416	16.3	16	20	59	27

1) For max Ø AT-cable

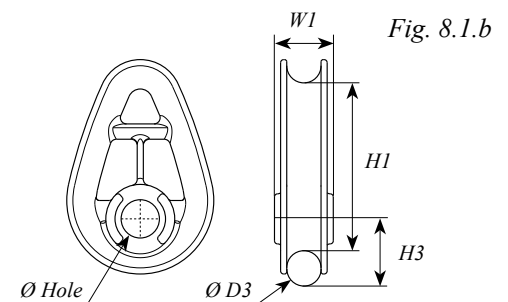

### Thimbles for double luff rope

System	Part no.	Ø Hole mm	D4 mm	W2 mm	W3 mm	H2 mm
CX10/15	545-115	10.3	8	16	22	34
CX/CXe25	545-215	12.3	8	19	27	42
CX40&CX/CXe45	545-415	16.3	12	20	33	52

