

# Furlex TD MkII

**FURLEX**  
204 TD

**FURLEX**  
304 TD

**FURLEX**  
404 TD



 **SELDÉN**  
*for sailing*

# Maximise your boat's potential and let the Furlex system work without being seen.

Tacking the sail at deck level allows for a longer luff length of your foresail. You will improve sailing performance without compromising the convenience of the jib furling system. The bow will also be less cluttered as the line drum is hidden below the deck.

The free turn of the tack swivel is the same as in all other Furlex models; a necessity to reduce the furling resistance and to flatten out a reefed genoa.

The MkII version of Furlex TD (Through Deck) has all the benefits developed for the standard 4th generation Furlex, such as, smooth furling with roller bearings combined with stainless ball bearings for the drum and an optional rigging screw to adjust the forestay length. In addition, the outside diameter of the line drum is smaller than on earlier TD models which simplifies installation in narrow anchor boxes and allows for installation further forward.

Optional rigging screw

204TD: 60 mm  
304TD: 80 mm  
404TD: 100 mm

Tack attachment with free turn for reduced initial furling resistance and a flatter reefed sail.

Deck bearing

Adjustable fork terminal

Stainless torque tube

Gimbal joint at low position for improved furling

Composite through deck fitting

Small outer diameter of the drum



**FURLEX TD**



Spherical roller bearing at deck level to cope with 17° forestay, angle +/- 3°.

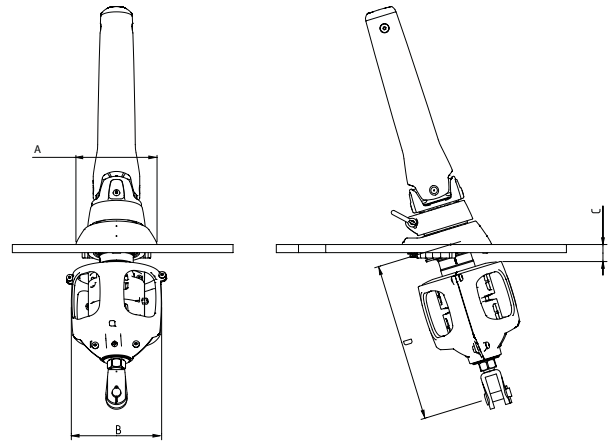

Type	A	B	C	D
204TD	126	147	22	250-415
304TD	150	167	31	300-500
404TD	182	210	40	375-540

Type	Forestay dimension, mm	Max. forestay length (mm)*	Standard Sta-lok terminal Art. No**	Sta-lok terminal & rigging screw Art. No**	Stud terminal for swaging Art. No**
204TD	6	10500	035-025-31	035-025-39	035-025-15
	6	12900	035-025-32	035-025-40	035-025-16
	6	15300	035-025-33	035-025-41	035-025-17
	7	12900	035-025-34	035-025-42	035-025-18
	7	15300	035-025-35	035-025-43	035-025-19
	7	17700	035-025-36	035-025-44	035-025-20
	8	15300	035-025-37	035-025-45	035-025-21
	8	17700	035-025-38	035-025-46	035-025-22
304TD	8	15260	042-031-41	042-031-46	042-031-89
	8	17660	042-031-42	042-031-47	042-031-90
	10	15260	042-031-43	042-031-48	042-031-96
	10	17660	042-031-44	042-031-49	042-031-97
	10	20060	042-031-45	042-031-50	042-031-98
404TD	12	17380	052-038-31	052-038-36	052-038-41
	12	19780	052-038-32	052-038-37	052-038-42
	12	22180	052-038-33	052-038-38	052-038-43
	14	19780	052-038-34	052-038-39	052-038-44
	14	22180	052-038-35	052-038-40	052-038-45

\*From deck to forestay attachment. \*\*All models include a 1x19 strand forestay wire. For Compact wire (Dyform) add "C" after the Art. No. Furlex TD can also be installed on rod.

# DINGHIESKEELBOATSYACHTS

**Seldén Mast AB, Sweden**  
Tel +46 (0)31 69 69 00  
e-mail [info@seldenmast.com](mailto:info@seldenmast.com)

**Seldén Mast Limited, UK**  
Tel +44 (0) 1329 504000  
e-mail [info@seldenmast.co.uk](mailto:info@seldenmast.co.uk)

**Seldén Mast Inc., USA**  
Tel +1 843-760-6278  
e-mail [info@seldenus.com](mailto:info@seldenus.com)

**Seldén Mast A/S, DK**  
Tel +45 39 18 44 00  
e-mail [info@seldenmast.dk](mailto:info@seldenmast.dk)

**Seldén Mid Europe B.V., NL**  
Tel +31 (0) 111-698 120  
e-mail [info@seldenmast.nl](mailto:info@seldenmast.nl)

**Seldén Mast SAS, FR**  
Tel +33 (0) 251 362 110  
e-mail [info@seldenmast.fr](mailto:info@seldenmast.fr)

**Seldén Mast Asia Ltd,  
Hong Kong**  
Tel +852 3572 0613  
e-mail [info@seldenmast.com.hk](mailto:info@seldenmast.com.hk)

[www.seldenmast.com](http://www.seldenmast.com)

Dealer:

The Seldén Group is the world's leading manufacturer of mast and rigging systems in carbon and aluminium for dinghies, keelboats and yachts.

Our well known brands are Seldén and Furlex. The worldwide success of Furlex has enabled us to build a network of over 750 authorised dealers covering the world's marine markets. So wherever you sail, you can be sure of fast access to our service, spare parts and know-how.

SELDÉN and FURLEX are registered trademarks of Seldén Mast AB

