

S M F

SYNCHRONIZED MAIN FURLING

Upgrade your furling mast to electric drive

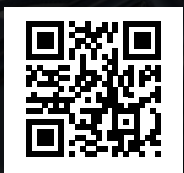

Scan and watch
Synchronized Main
Furling



SELDÉN
for sailing

To make sail handling easier for a small crew we have synchronized an electric motor in the mast with a newly developed electric winch for the outhaul, E40i. Push a button and the sail comes out in a controlled fashion as the winch adjusts the outhaul tension in relation to the motor in the mast.



IN-MAST FURLING MOTOR

Converting a manually operated furling mast is quite easy. Basically, the vertical shaft in the original line driver is replaced for a longer version which is connected to the motor. A clutch allows the motor to be disconnected for manual operation, if ever needed. The motor is completely integrated in the mast and connected to the Seldén Power Supply and SEL-Bus system.

The motor can be retrofitted to Seldén furling masts type RB and RC (~36-50' yachts).

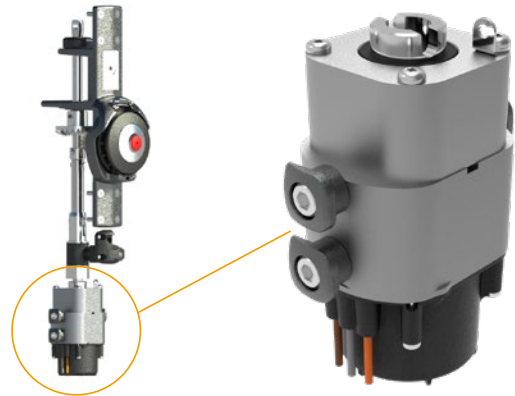

PUSH BUTTONS

Push the "OUT" button and the sail will start to unfurl. The E40i winch will tension up the outhaul while the mast motor feeds out the sail. The speed is increased when the "IN" button is pushed in addition to "OUT". To reef, just release the outhaul from the winch and push "IN".

E40i ELECTRIC WINCH

The E40i winch is built up around an electric motor which is totally integrated in the drum. Only three thin cables are protruding to lead through the coach roof or the deck, no large cutouts and no external motor or gearbox. This makes for uncompromised headroom down below which is normally not the case with electric winches.

The three speed operation provides a high speed gear, a moderate gear and a low speed gear for fine tuning. It is a two finger operation to start the winch and to switch gear, so a single-handed sailor can helm while adjusting the trim.



HOW IT'S CONNECTED

Power supply & SEL-Bus system

The Seldén Power Supply System converts 12V or 24V to 42V which allows for smaller motors and thinner cables. Each electric function has a dedicated motor control unit and as they are connected through a Can Bus system, named "SEL-Bus", they communicate for smooth operation of the sail without overloads.

When not in use, the system will switch into sleep mode to save power.

1. Battery
2. Main switch/fuse
3. Power Supply Unit (PSU). Converts 12/24V to 42V
4. Push buttons for Synchronized Main Furling
5. E40i electric winch
6. Motor Control Unit (MCU), E40i
7. Push buttons for E40i
8. Mast motor
9. Motor Control Unit (MCU), mast motor
10. SEL-Bus backbone cables and connections

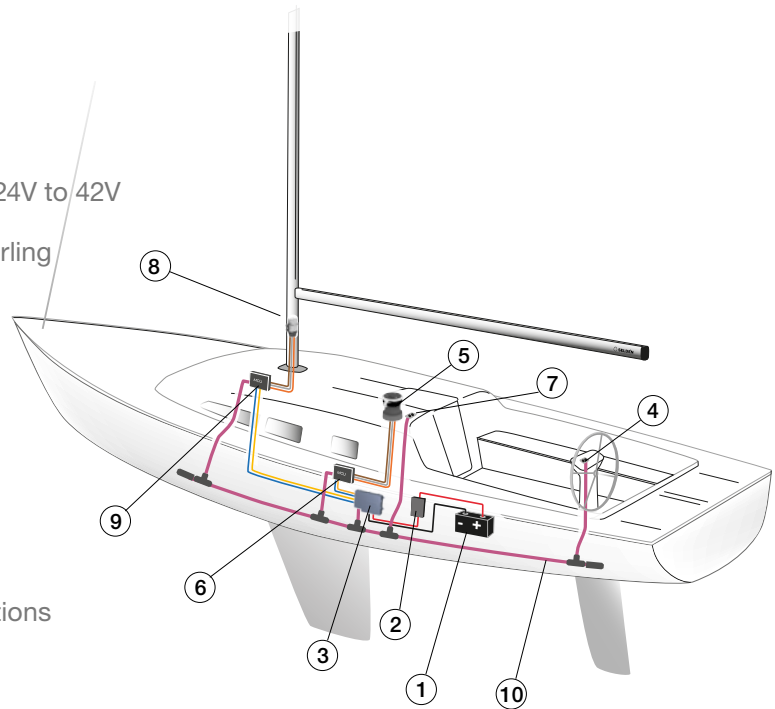

MAST SECTIONS THAT CAN BE UPGRADED TO SMF

Mast section	Section dimensions, mm Long/Lat	Production years
R232	232/126	1986-2002
R260	260/136	1986-2002
F228*	228/118	2002-
F246	246/126	2002-
F265*	265/135	2002-
F286*	286/146	2002-
F305*	305/156	2002-

*These sections have been combined with RA, RB or RC furling systems. SMF is available for RB systems and RC systems featuring ø30 mm and ø38 mm furling extrusions respectively (RA=ø25 mm).

Ordering SMF

Contact a rigger or a service yard representing Seldén for a quote including installation.

Technical information and part numbers are available at www.seldenmast.com/technical information.

DINGHIESKEELBOATSYACHTS

Seldén Mast AB, Sweden

Tel +46 (0)31 69 69 00
e-mail info@seldenmast.com

Seldén Mast Limited, UK

Tel +44 (0)1329 50 40 00
e-mail info@seldenmast.co.uk

Seldén Mast Inc., USA

Tel +1 843-760-6278
e-mail info@seldenus.com

Seldén Mast A/S, Denmark

Tel +45 39 18 44 00
e-mail info@seldenmast.dk

**Seldén Mid Europe B.V.,
Netherlands**

Tel +31 (0)111-698 120
e-mail info@seldenmast.nl

Seldén Mast SAS, France

Tel +33 (0)251 362 110
e-mail info@seldenmast.fr

**Seldén Mast Asia Ltd,
Hong Kong**

Tel +852 3572 0613
e-mail info@seldenmast.com.hk

www.seldenmast.com

The Seldén Group is the world's leading manufacturer of mast and rigging systems in carbon and aluminium for dinghies, keelboats and yachts.

Our well known brands are Seldén and Furlex.

The worldwide success of Furlex has enabled us to build a network of over 750 authorised dealers covering the world's marine markets. So wherever you sail, you can be sure of fast access to our service, spare parts and know-how.

SELDÉN and FURLEX are registered trademarks of Seldén Mast AB.