

Manual for 2-speed self-tailing winches *S30, S40, S48 & S54*

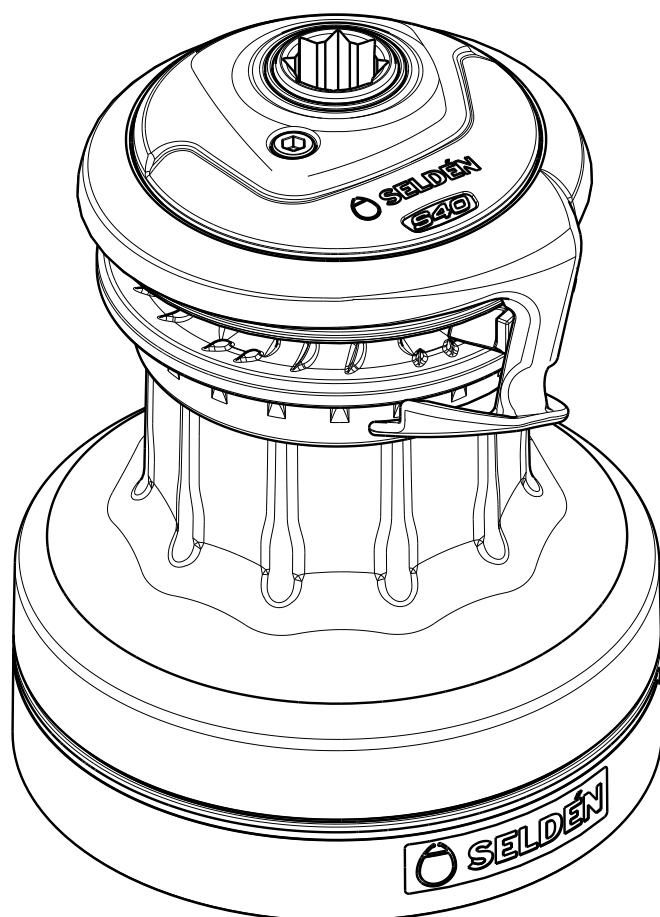

Contents

	<i>Page</i>
1 Introduction	3
1.1 <i>The manual</i>	3
1.2 <i>Warranty</i>	3
1.3 <i>General warning & instructions</i>	4
1.4 <i>Product information</i>	4
1.4.1 <i>Seldén winch range</i>	4
1.4.2 <i>S-winch feature</i>	4
1.4.3 <i>Winch handle</i>	5
1.4.4 <i>Technical data</i>	5
1.4.5 <i>Parts and descriptions</i>	6
2 Operation instructions	7
2.1 <i>Winch handle</i>	7
2.2 <i>Winching</i>	7
3 Installation	8
3.1 <i>Installation preparations</i>	8
3.1.1 <i>Winching orientation</i>	8
3.1.2 <i>Line routing</i>	8
3.2 <i>Installation instructions</i>	9
3.2.1 <i>Installation with hexagon headed bolts (Sliding bolts)</i>	9
3.2.2 <i>Adjustment of the self-tailing arm</i>	10
3.2.3 <i>Installation with hexagon socket head cap screws (Allen screws)</i>	11
4 Dismantling and maintenance	15
4.1 <i>Dismantling for normal service</i>	15
4.2 <i>Dismantling for extended service</i>	18
4.3 <i>Service instructions</i>	21
5 Notes	22

1 Introduction

1.1 The manual

To achieve the maximum benefit and enjoyment from your Seldén winch, we recommend that you study this manual carefully.

All safety-related information is indicated by the following symbol:



The manual covers 4 different winch sizes; S30, S40, S48 and S54. The model designation can be found on the top of the winch.

Identification-/serial number is located inside the winch, but also on the delivery box.

The Seldén winch installation system is based on metric screws/bolts.

This manual will be updated subsequently. For the latest update check www.seldenmast.com

1.2 Warranty

Seldén Mast AB guarantees the winch for 2 years. The guarantee covers faults arising from defective design, materials or workmanship.

The guarantee is only valid if the winch is installed, operated and maintained in accordance with this manual and is not subjected to loads in excess of those indicated in the brochure and instructions.

If the winch is repaired by anyone else other than Seldén Mast AB or one of our authorized dealers, the guarantee ceases to be valid.

The Seldén winch is designed for line handling on sailboats only.

Complete shipment and warranty conditions are to be found on Seldén's website www.seldenmast.com. See Technical information/ General conditions of sale (595-546-E).

Seldén Mast AB reserves the right to alter the content and design without prior warning.



This information must be followed to avoid damage to the winch and risk of personal injury. The 2-year warranty on the Seldén winch is only valid if the winch is installed and operated correctly according to the manual.

1.3 General warning & instructions

Make sure the winch is dimensioned according to Seldén's design standards and not subjected to loads greater than those stated in the brochure and instruction materials and is used solely for its intended use, i.e. normal sailboat applications for running rigging.

Exceeding the stated maximum working load (MWL) may lead to winch failure or that the winch detaches from the boat which may lead to serious injuries.

Keep hands, fingers, hair and clothing away from moving parts. It is recommended to let only one person, work with the winch at any one time.

If a Seldén winch, despite the above, is used for going aloft in the mast, double halyards must be used, to be hauled in and eased off at the same time. (Seldén rigging manual "Hints & Advice", 595-540-E, "Working aloft").

For your own personal safety, make sure the winch is installed, regularly inspected and maintained according to this manual.

This manual is available in English only. If you do not understand the manual content we advise you to obtain expert assistance for the installation and operation!



The Seldén winch is designed for line handling on sailboats only!



Exceeding maximum working load may lead to winch failure or serious injuries.

1.4 Product information

1.4.1 Seldén winch range

Seldén have two ranges of winch, S-winch and the R-winch, which are manually operated and of self-tailing type with two forward gears.

The difference between these two models are that the R-winch is reversible, which means it is possible to let the line out by reversing the winch drum using the winch handle. The S-winch does not have this feature.

1.4.2 S-winch features

With modern manufacturing technology and by optimizing the choice of materials Seldén have succeeded to reduce the weight and the need of maintenance to a minimum.

The drum has a unique design consist of several concave surfaces which provide an extraordinary grip for the line. It means fewer turns on the drum which reduces the risk of an overwrap and allows the line to be released quickly.

The self-tailing jaws has a design which makes it possible to pull the slack out of the sheet with the line sitting in the self-tailer and with the winch handle mounted. This means safer and quicker operation.



The S-winch has two different fastening methods:

1. By hexagon headed bolts which slide into a groove in the winch base and where the hexagon heads are locked against rotation due to the winch base structure. This method allows installation without dismantling the winch. The bolts are fitted through deck and fastened using washers and nuts. (See fig.3.2.1.c).
2. By hexagon socket head cap screws (Allen screws) mounted from above. The winch needs to be dismantled. E.g. for cases where the boat is prepared with metal inserts in the deck construction. (See fig. 3.2.3.j).

See chapter “Installation” for requested screw type and dimension.

1.4.3 Winch handle

Seldén have two different models of winch handles designed for S-winch and R winches respectively. The winch handle for the R-winch differs from the S-winch handle by it having a button for a reverse function on the grip. Both winch handles fit in each winch model and works for forward winching, while the reverse function on R-winch only can be operated by the R-winch handle.

S-winch handle	R-winch handle
Art. No. 533-927-20	Art. No. 533-927-10
 <p>Fig. 1.4.a</p>	 <p>Fig. 1.4.b</p>

1.4.4 Technical data

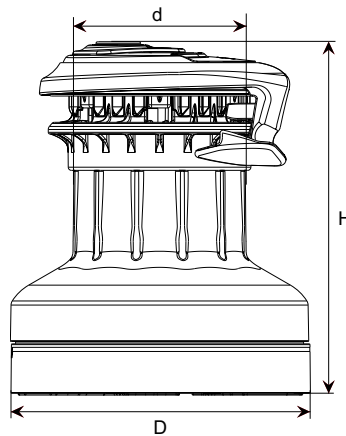

Fig. 1.4.c

Winch size	Art. No.	Base dia (Ø D mm)	Drum dia (Ø d mm)	Height (H mm)	Weight (kg)	Line size (mm)	Power ratio High gear	Power ratio Low gear	Maximum working load (MWL)
S30	472-630-10	Ø 150	Ø 85	185	3.2	8-12	10:1	30:1	900 kg (1984 lb)
S40	472-640-10	Ø 150	Ø 85	185	3.2	8-12	10:1	40:1	900 kg (1984 lb)
S48	472-648-10	Ø 188	Ø 108	222	5.1	10-14	10:1	48:1	1000 kg (2204 lb)
S54	472-654-10	Ø 188	Ø 108	222	5.1	10-14	10:1	54:1	1300 kg (2866 lb)

1.4.5 Parts and descriptions

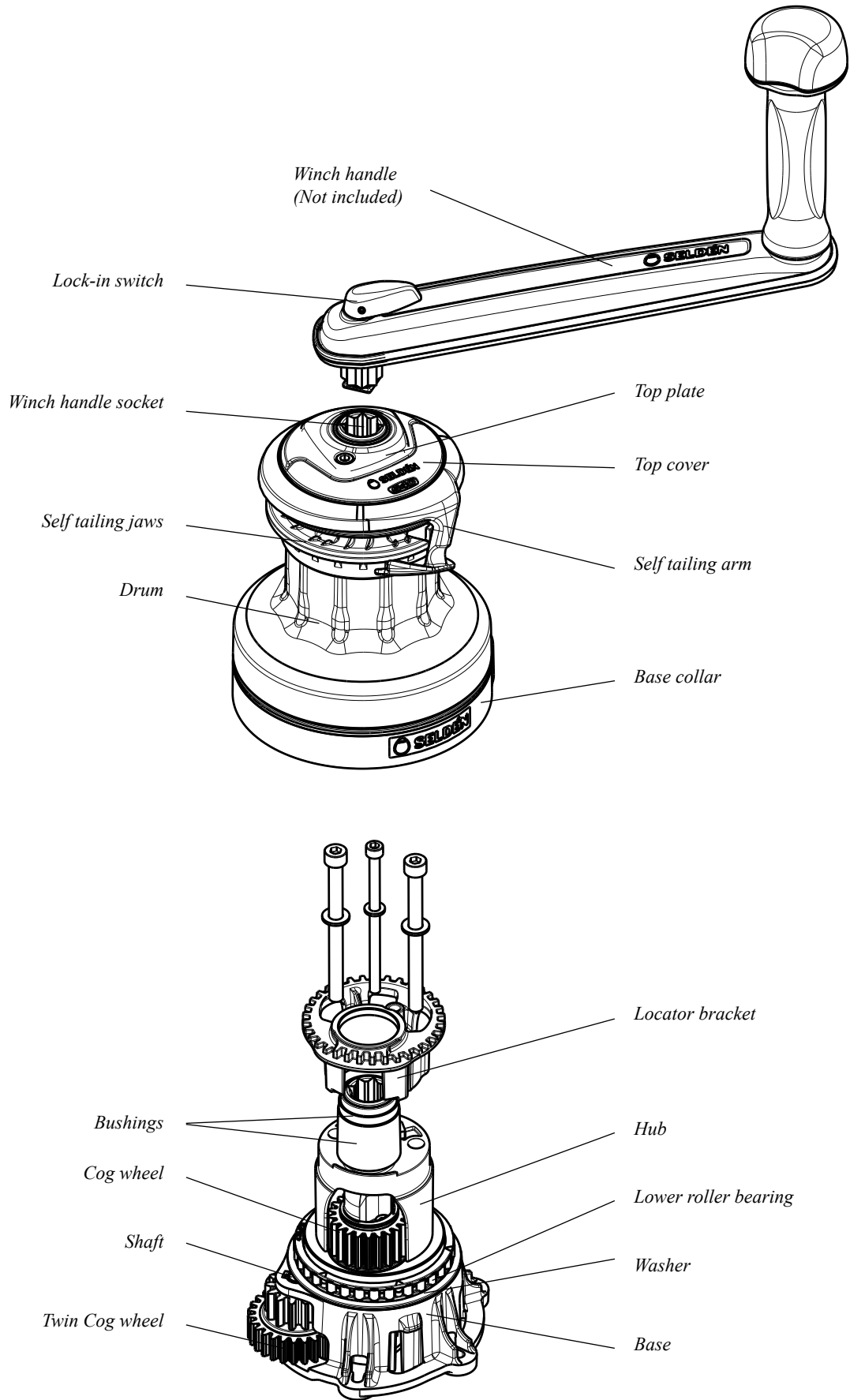
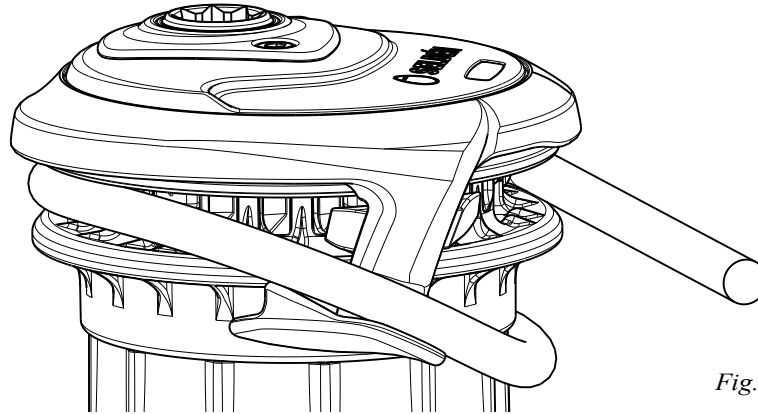

Fig. 1.4.d

2 Operation instructions

Seldén S-winches are manually operated and are a self-tailing type with two forward gears.

1. With the line, take 2-3 turns clockwise around the winch. The number of turns determines the grip and is related to the line construction.



2. Lead the line over the self-tailing arm, into the self-tailing jaws for $\frac{3}{4}$ of a lap. The line remains in the self-tailing jaws all the time during the winching operation.
3. Put the winch handle into the socket.

Due to the design of the self-tailing jaws it is also possible to pull the slack out of the sheet with the line sitting in the self-tailing jaws and with the winch handle mounted. This means safer and quicker operation.

2.1 Winch handle

The purpose of the winch handle is to operate the winch. The S-winch handle (Art. No. 533-927-20) has no reverse button and does not work with the reversible R-series. R-winch handle (Art. No. 533-927-10) with release button does work with the S-winch series. See fig. 1.4.a and 1.4.b.

2.2 Winching

Fast gear: Turn the winch handle clockwise.

Low gear: Turn the winch handle anticlockwise.



Consider the risk of injury which is associated with winching! See chapter 1.3.

3 Installation

3.1 Installation preparations

1. The winch should be mounted on a flat surface. If not, any uneven surface must be compensated with shims.
2. Make sure the installation area is strong enough for the chosen size of winch.
3. The winch should not be mounted on any part of deck that is laminated using sandwich construction, such as foam, etc.
4. If the winch is to be mounted on a surface of steel, bronze or brass, the base must be insulated against galvanic corrosion. This is best done using a plastic insulator (0.5-1 mm) or sealant which covers the entire contact area between the base and the mounting surface.

3.1.1 Winching orientation

Decide the orientation of the winch according to operation direction, with reference to the mostly used line and the bulb on the winch base. See fig. 3.1.1.a or the drilling template, enclosed in the winch package.

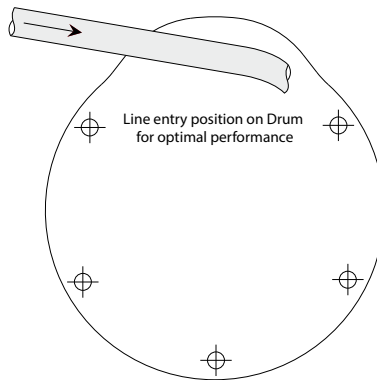

Fig. 3.1.1.a

3.1.2 Line routing

The line should enter the winch according to fig. 3.1.2.a to prevent from override.

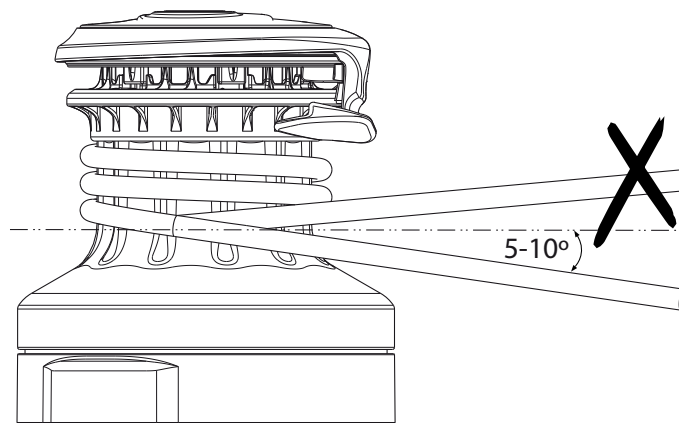
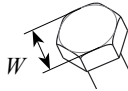
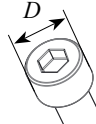



Fig. 3.1.2.a

3.2 Installation instructions

The winch has two systems for installation:

1. Hexagon headed bolts which slides into a groove in the winch base and where the hexagon heads are locked against rotation due to the winch base structure. No need to dismantle the winch. To be used with washers and nuts below deck. See chapter 3.2.1.
2. Hexagon socket head cap screw (Allen screws), mounted from above. The winch needs to be partly dismantled. E.g for cases where boats are prepared with metal inserts in the deck construction. See chapter 3.2.2.

Winch	Hexagon headed bolts	Hexagon socket head cap screws	Cheese headed screws
			
	W	D_{max}	
S30	10 mm	10 mm	Cheese headed screws are generally to large in diameter to fit.
S40			
S48	13 mm	13 mm	
S54			

3.2.1 Installation with hexagon headed bolts (sliding bolt system)

1. Cut the enclosed drill template to match the winches outline.
2. Place the template on deck at the desired position according to chapter 3.1.1 "Winching orientation"
3. Drill the holes through deck using a drill according to the table below. We recommend predrilling with a smaller drill for better accuracy.

Winch	Screw/Thread	Drill for through deck fastening	Drilling template
S30	M6	Ø 7 mm	597-226-E
S40			
S48	M8	Ø 9 mm	597-227-E
S54			

4. Cut the enclosed drill template to match the winches outline.
5. Place the template on deck at the desired position according to chapter 3.1.1 "Winching orientation."

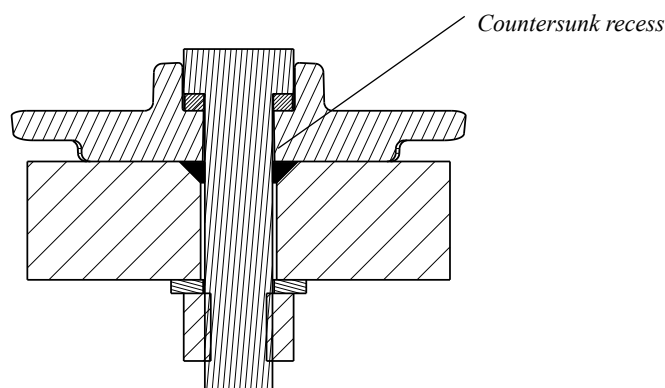

Fig. 3.2.1.a

6. Drill the holes through deck using a drill according to table the table below. We recommend predrilling with a smaller drill for better accuracy.

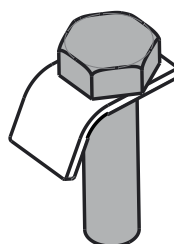

Fig. 3.2.1.b

7. Slide on an L-shaped washer onto each bolt according to fig 3.2.1.b.
8. Mount the screw by sliding the hexagon head and the L-shaped washer into the base and apply sealant into the U-recess and around the screw. Apply enough sealant to fill the entire cavity under the L-washer and the countersunk recess at the holes in the deck.
9. Install the winch with the bolts into the deck simultaneously. Mount the washers and nuts below deck and tighten opposite nuts from below, according to fig. 3.2.1.c (bottom, right).

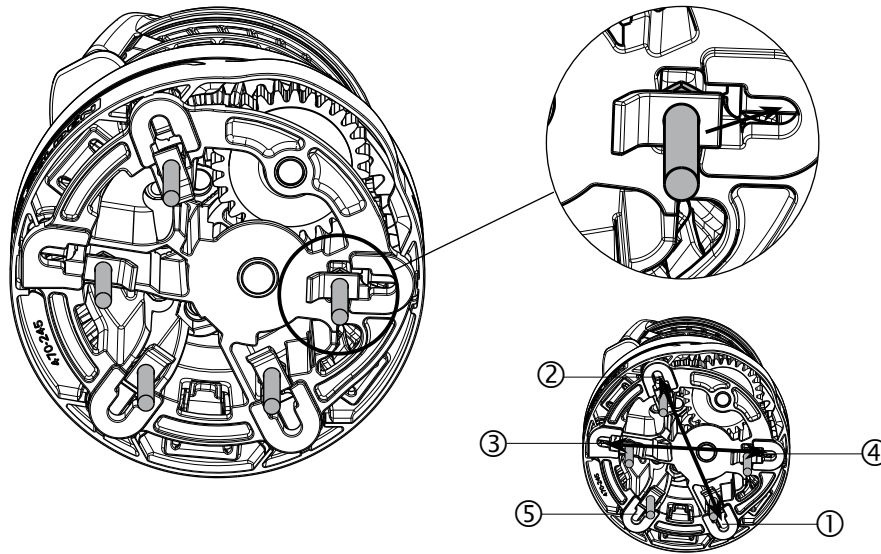

Fig. 3.2.1.c

Crosswise tightening

3.2.2 Adjustment of the self-tailing arm

The direction of the Self-tailing arm may be adjusted. Preferably it should be mounted so that the line feeds into the cockpit when using the winch.

Tools needed: Hexagon key 5 (M6).

1. Remove the cap screw (1), the top plate and the top cover.

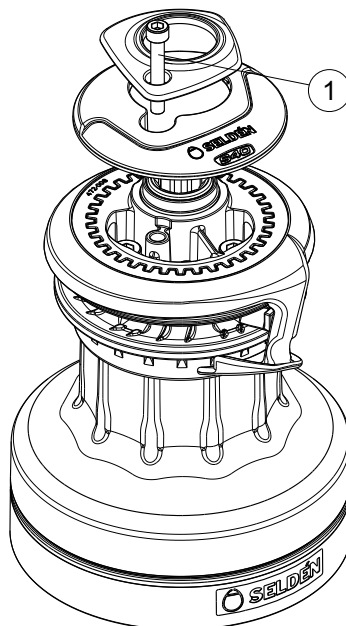

Fig. 3.2.2.a

2. Push the Self tailing arm upwards while the opposite side of the ring is lifted out of its position.
3. Turn it to the desired position.
4. Reassemble the parts in reverse order.

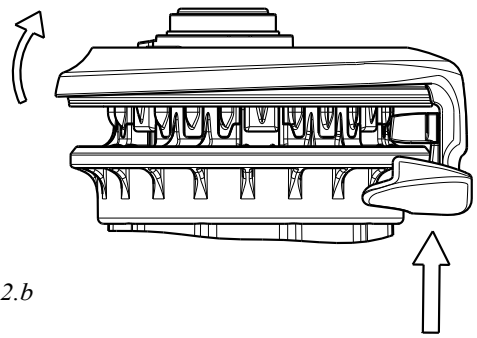

Fig. 3.2.2.b

3.2.3 Installation with Hexagon socket head cap screw (Allen screws) with cylindric head (None sliding bolt installation)

If the winch should be fitted with Hexagon socket head cap screw (Allen screws), the winch must be partly disassembled. This method of installation has to be used for threading into the deck, e.g. if the boat has purpose made metal plates laminated into the deck structure or if non-hexagon headed through deck screws are used with washer and nuts.

Tools needed for winch dismantling:

- S30 & S40: Hexagon key 5 (M6), Hexagon key 6 (M8)
 S48 & S54: Hexagon key 6 (M8), Hexagon key 8 (M10)

1. Remove the cap screw (1) on the top of the winch and remove the top plate and the top cover.

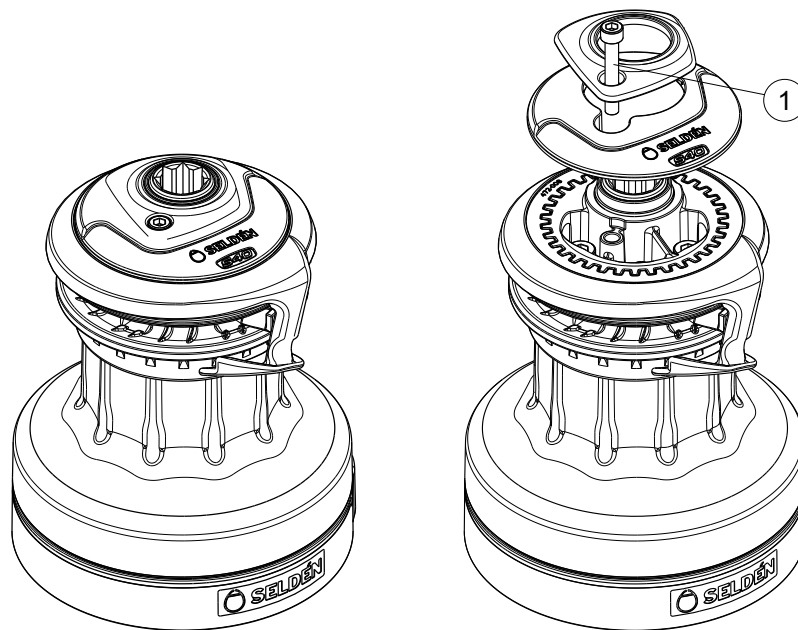

Fig. 3.2.3.a

2. Push the Self tailing arm upwards while the opposite side of the ring is lifted. Remove it.

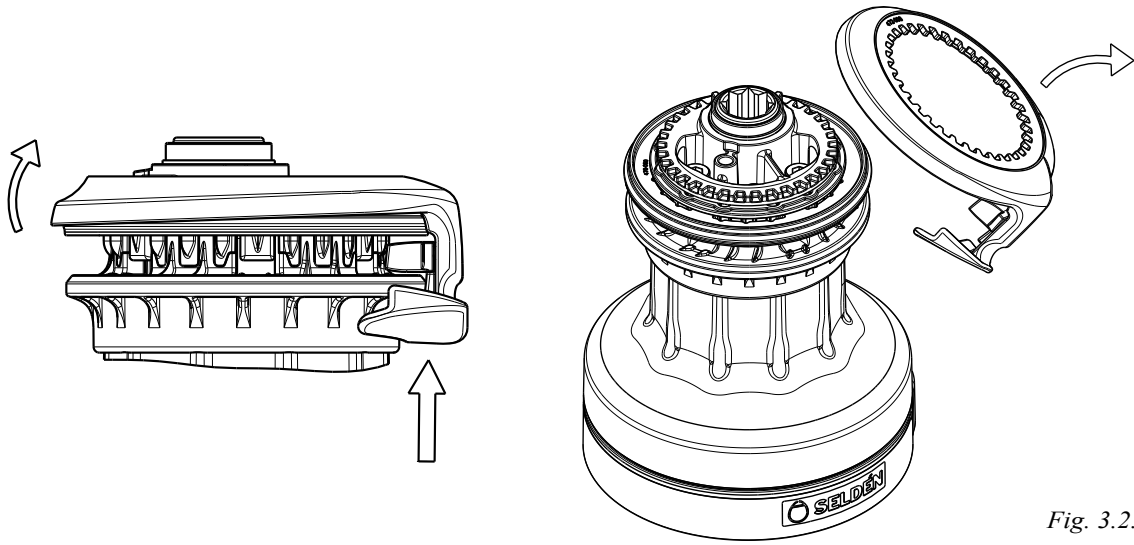

Fig. 3.2.3.b

3. Loosen the three screws which have now become visible. Remove the locator bracket (2).

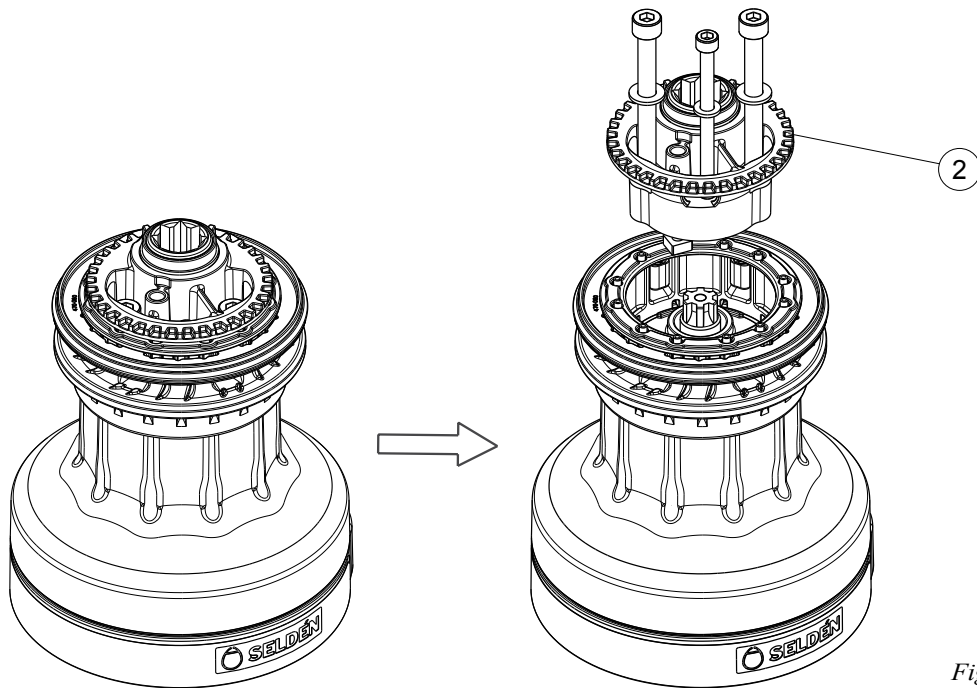

Fig. 3.2.3.c

4. Lift the drum/self tailing jaws (3) together straight up. Make sure the composite hub remains on the base.

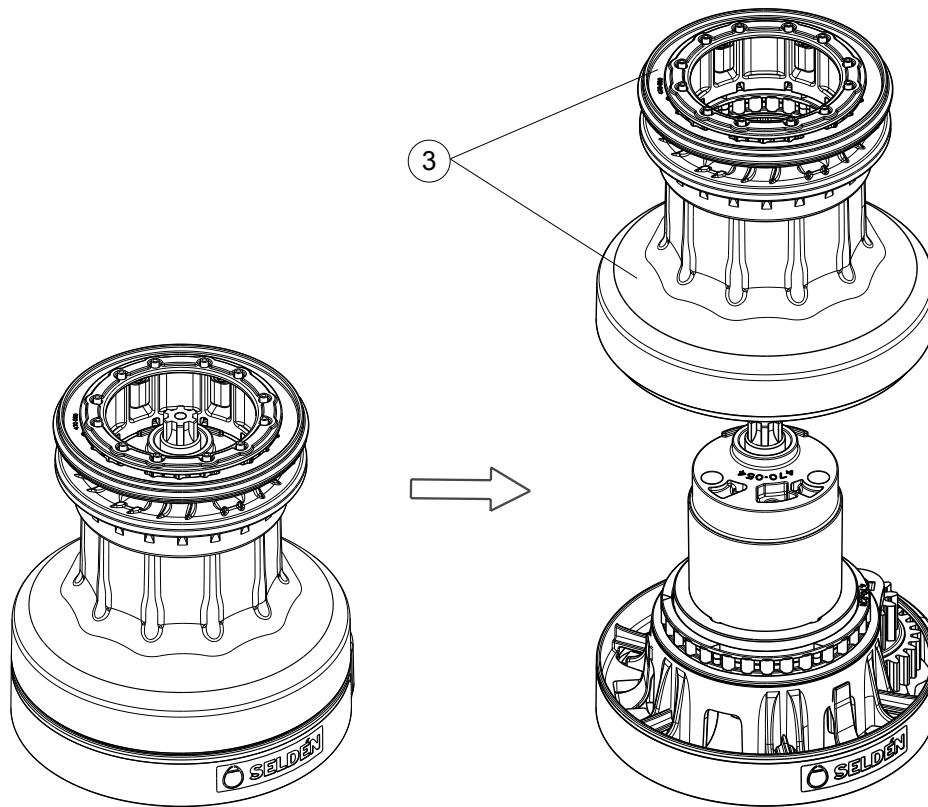

Fig. 3.2.3.d

5. Loosen the clip (5) (x3) carefully from the base while lifting the base collar (4) and remove it.

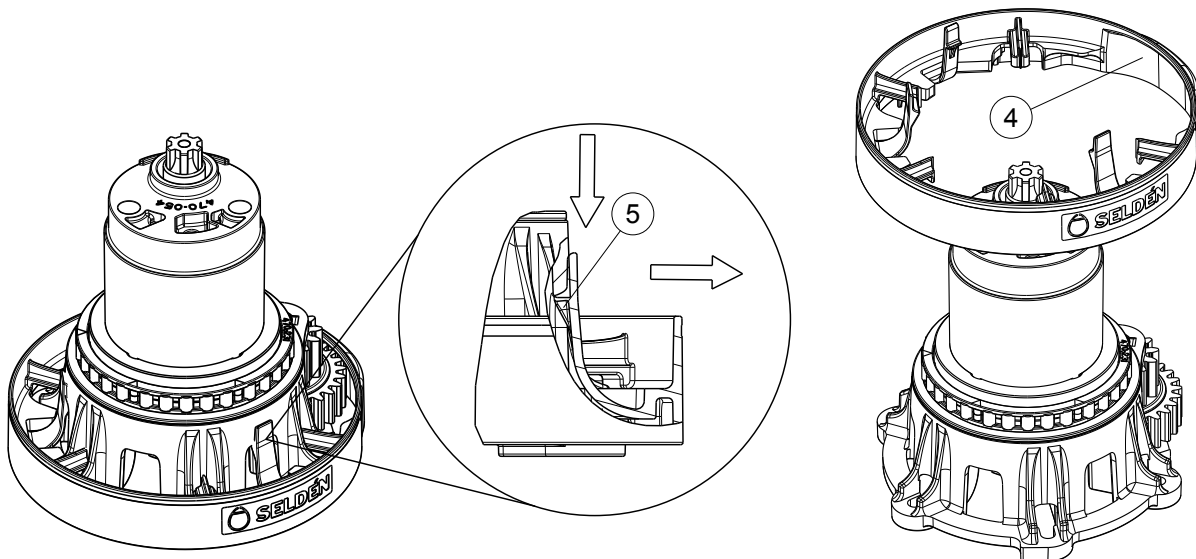
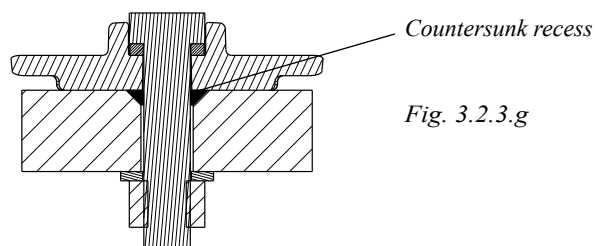

Fig. 3.2.3.e

- Mark the fastening holes using the winch base as a template or use the enclosed paper drilling template. If the winch base is used as a template, use a smaller drill bit to mark the location of the hole. If the paper drilling template is used, pre-drilling with a smaller drill (\varnothing 3-4 mm) is recommended for better accuracy.
- Drill either for through deck fastening or for threading in metal inserts.

Winch	Screw/Thread	Suitable size for marking	Drill for through deck fastening	Drill for thread in metal inserts	Drilling template
S30	M6	\varnothing 6 mm	\varnothing 7 mm	\varnothing 4.9 mm	597-226-E
S40					
S48	M8	\varnothing 8 mm	\varnothing 9 mm	\varnothing 6.5 mm	597-227-E
S54					

- Make a countersunk recess at the top of the holes. Along with the sealant, this recess will create aid sealing around the bolt.



- Through deck fastening:**

Slide an L-shaped washer onto each screw according to fig. 3.2.3.i. Mount the screws into the base and apply sealant into the U-recess and around the screw. Apply enough sealant to fill the countersunk recess at the hole in the deck. Install the base and screws, in the deck simultaneously. Mount the washer and nuts below deck. Hold the head of the screw without turning it while the nuts are tightened opposite nuts from below, according to fig. 3.2.3.k.

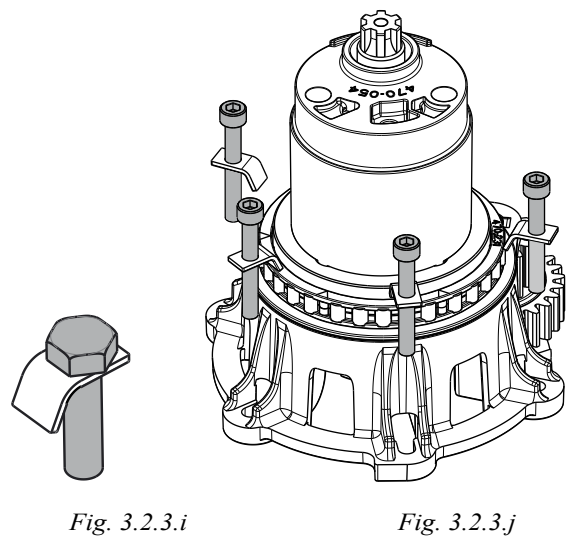
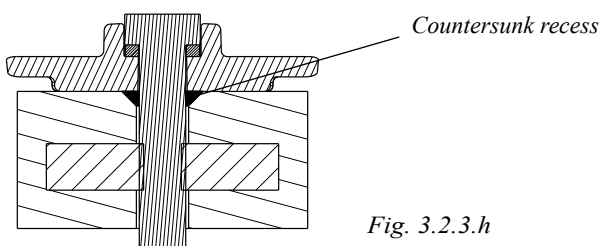

Fastening by threading:

Apply sealant into the countersunk recess at the top of the holes in deck. Make sure to get a full measure of sealant. Position the winch over the holes. Slide on an L-shaped washer on each screw according to fig. 3.2.3.i. and fit. Tighten opposite screws is recommended, according to fig. 3.2.3.k.

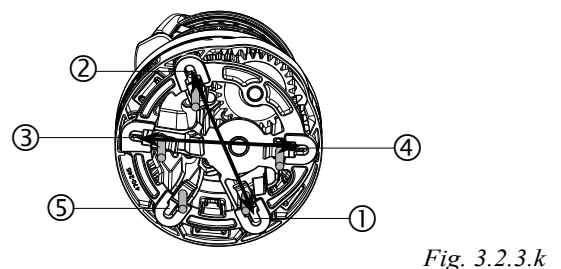

- Reassemble the winch in reverse order of dismantling. Mount the self tailing arm so it guides the line into the cockpit or preferred direction.

4 Dismantling and maintenance

To obtain full function and performance of the winch it is important that these maintenance instructions are followed carefully. Grease should be applied ONLY at these places where stated.

During dismantling, check wear and condition of all parts. Replace if necessary.

4.1 Dismantling for normal service

Tools needed:

S30 & S40: Hexagon key 5 (M6), Hexagon key 6 (M8)

S48 & S54: Hexagon key 6 (M8), Hexagon key 8 (M10)

1. Remove the cap screw (1) and remove the top plate and the top cover.

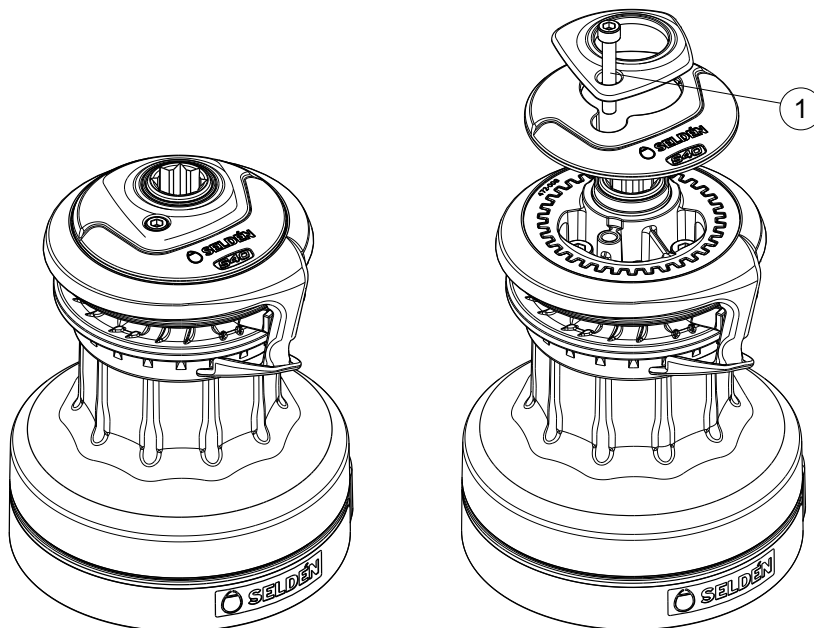

Fig. 4.1.a

2. Push the Self tailing arm upwards while the opposite side of the ring is lifted. Remove it.

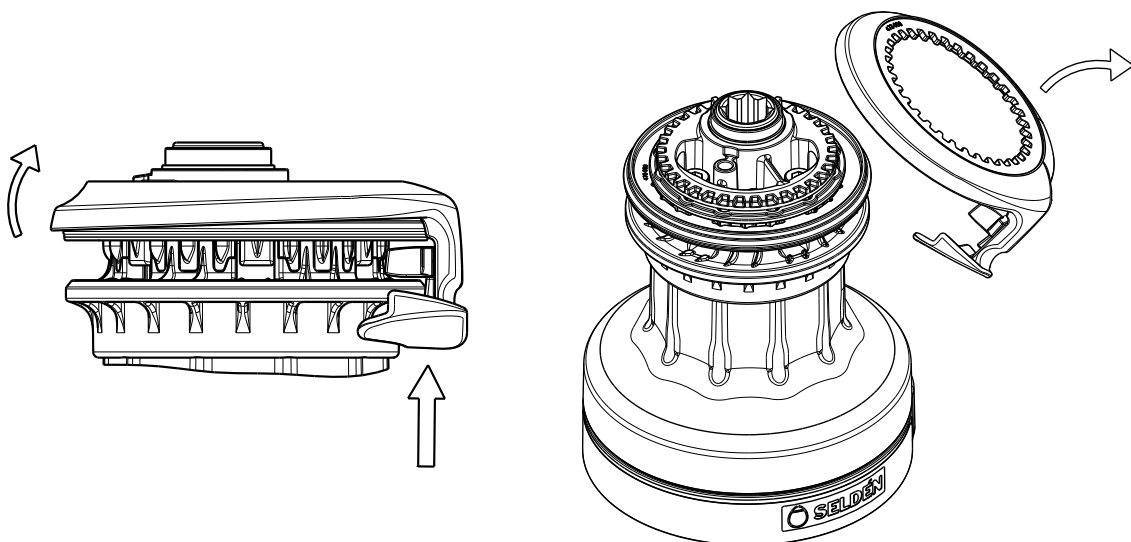

Fig. 4.1.b

3. Loosen the three screws which now has become visible. Remove the locator bracket (2).

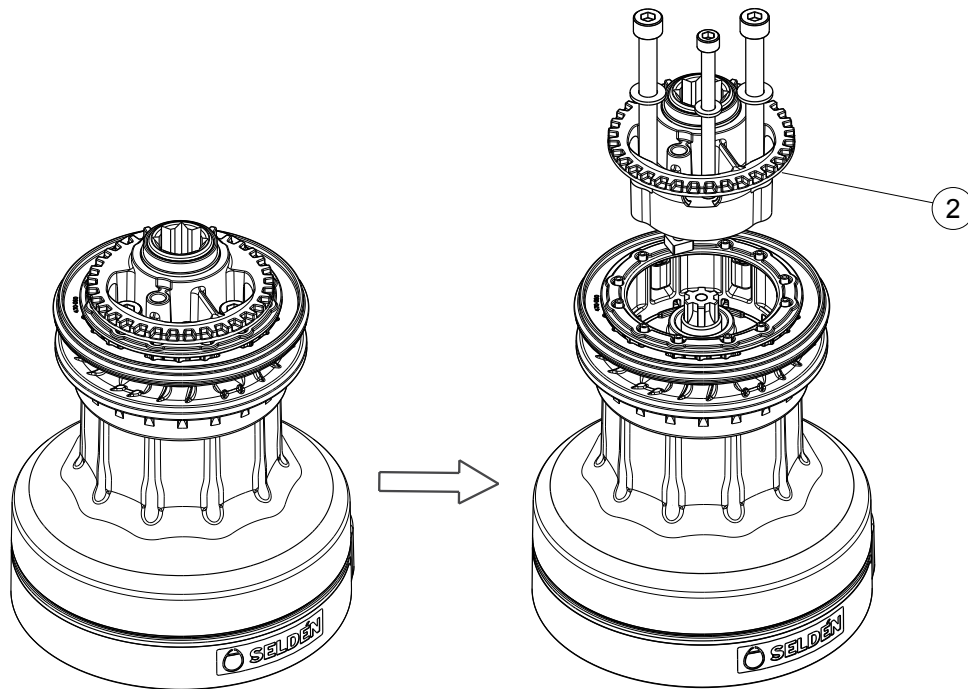

Fig. 4.1.c

4. Lift the drum/self tailing jaws (3) together straight up. Make sure the composite hub remains on the base.

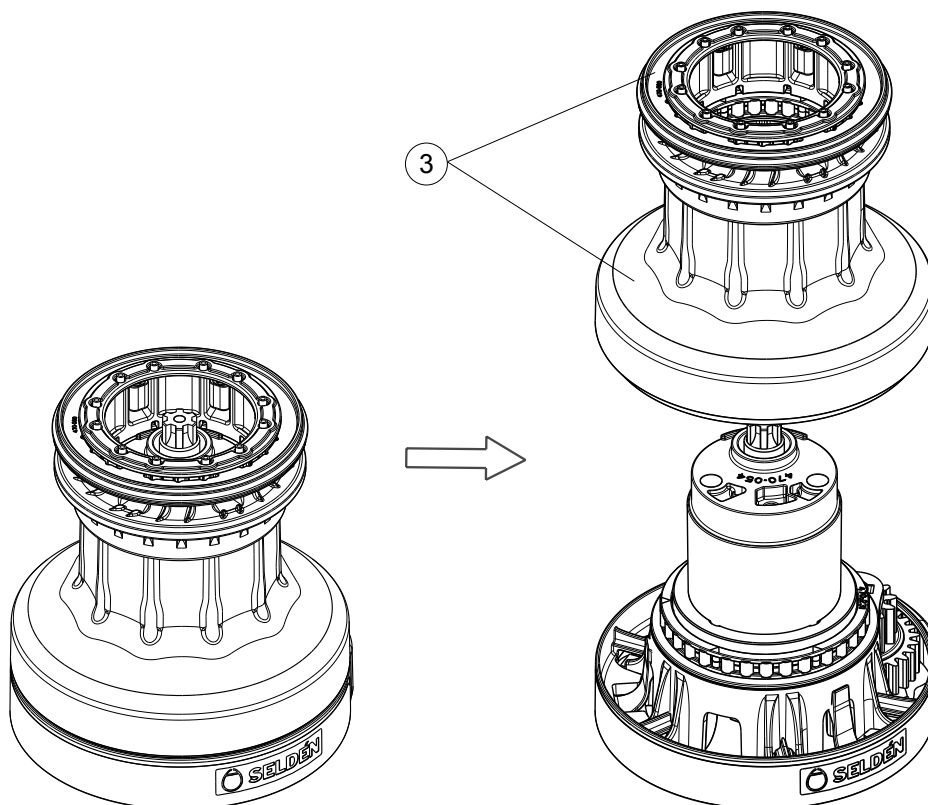

Fig. 4.1.d

- Loosen the clip (5) (x3) carefully from the base while lifting the base collar (4) and remove it.

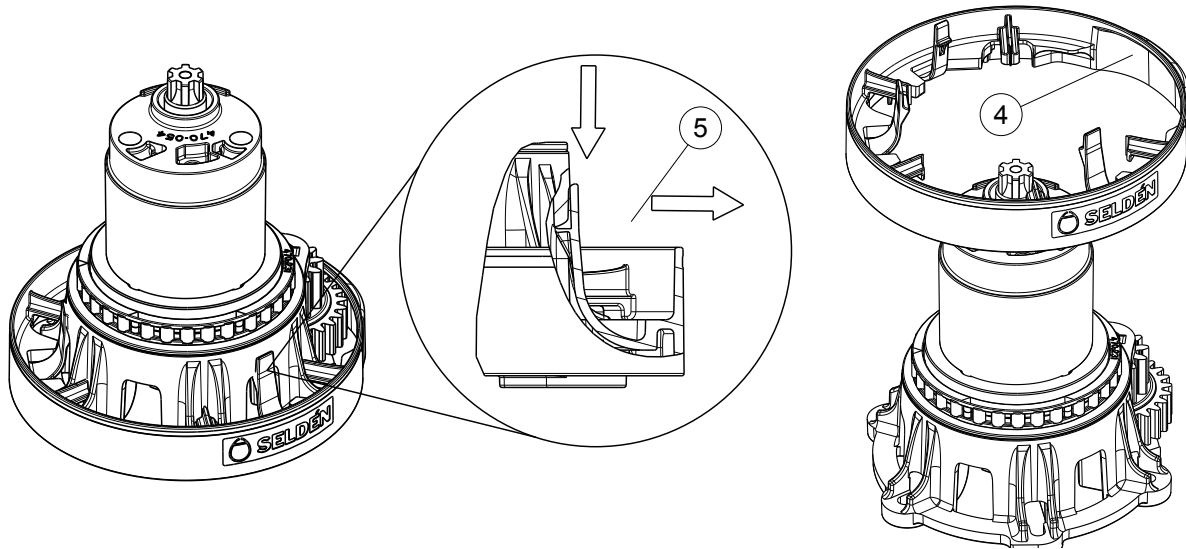

Fig. 4.1.e

- Remove the lower roller bearing (6) and the washer (7).

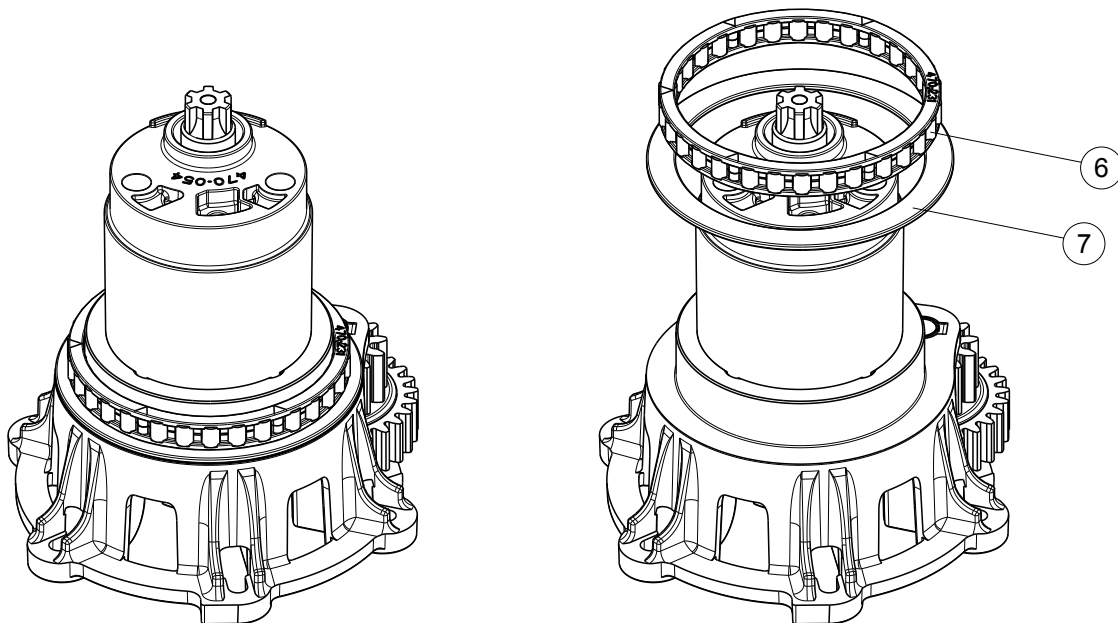

Fig. 4.1.f

- Perform service according to chapter 4.3 “Service Instructions”.
- Reassemble the winch in reverse order of dismantling. Mount the self tailing arm so it guides the line into the cockpit or preferred direction.

4.2 Dismantling for extended service

Continuation of the dismantling according to chapter 4.1 “Dismantling for normal service”, steps 1-6.

Keep careful track of the order in which the parts are dismantled.

Reassemble sub-assemblies directly after checking and cleaning if possible.

Handle all parts carefully. Place the disassembled parts on soft cloths or similar.

Tools needed:

Small-medium sized flat screwdriver

Needle nose pliers

Hexagon key 5 (M6)

1. Remove the shaft (8) and the twin cog wheel (9).



Fig. 4.2.a

2. Remove the washer (10). Note how this washer and ratchet wheel (11) are mounted. The washer has an asymmetrical rear and fit only to the ratchet wheel if this is fitted in the correct direction.



Fig. 4.2.b

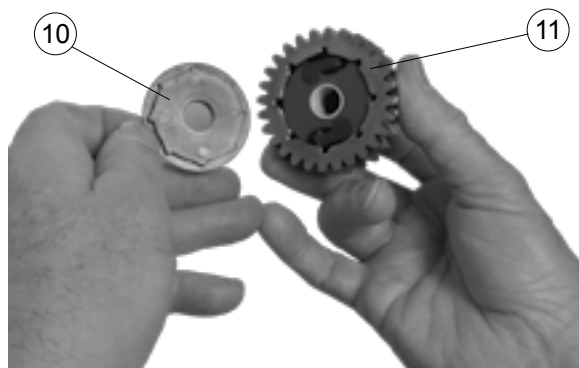

Fig. 4.2.c

3. Pull off the ratchet wheel and check functionality of the pawls (12). Dismantle the pawls and pawl springs if necessary. Worn pawls and springs should be replaced.

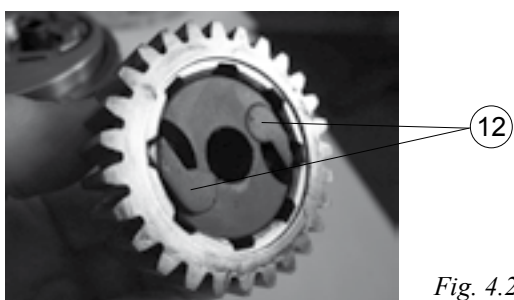

Fig. 4.2.d



Fig. 4.2.e

4. Lift out the winch handle socket (13) together with its bushings (14).

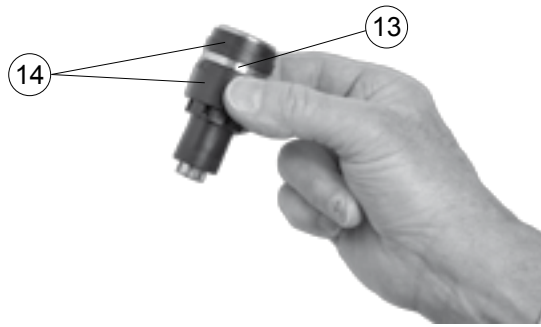

Fig. 4.2.f

5. Remove the hub (16) from the base.

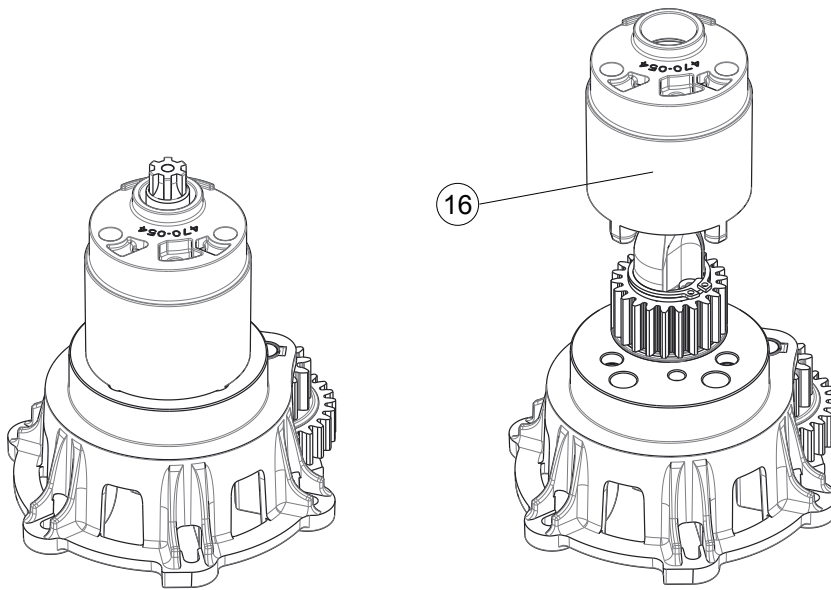

Fig. 4.2.g

6. Remove the drive shaft (17) from the base by lifting it straight up.

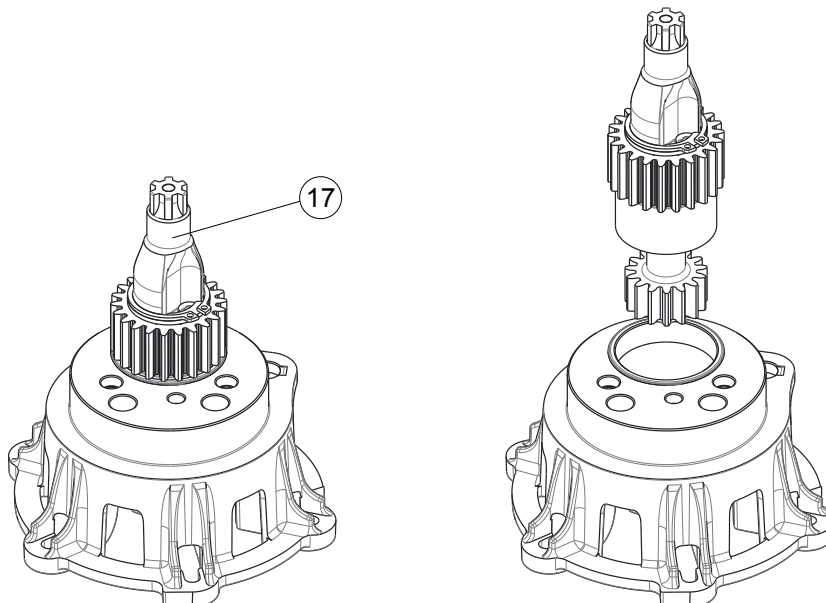

Fig. 4.2.h

7. Remove the circlip (18) and the washer (19) from the drive shaft.

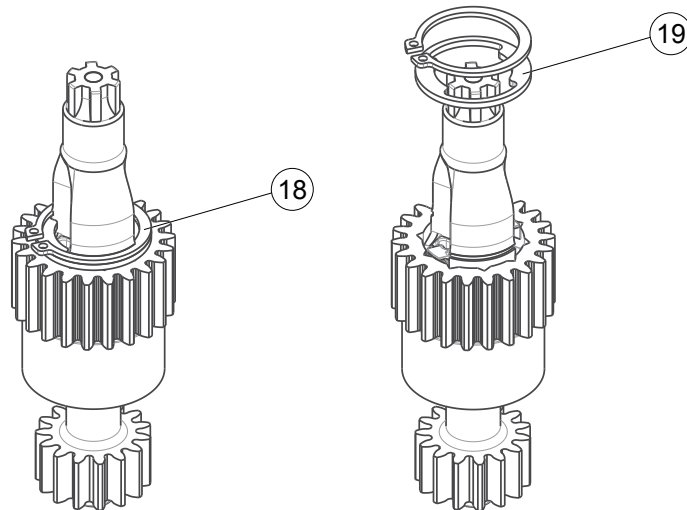

Fig. 4.2.i

8. To dismantle the pawls and pawl springs remove the gear wheel (20).

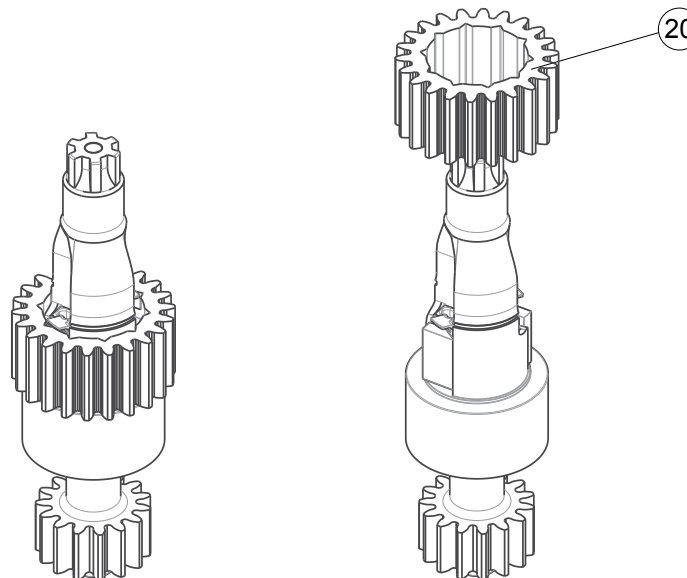

Fig. 4.2.j

9. Check functionality of the pawls. Dismantle the pawls and pawl springs if necessary. Clean the parts to ensure full function. Worn pawls and springs should be replaced.

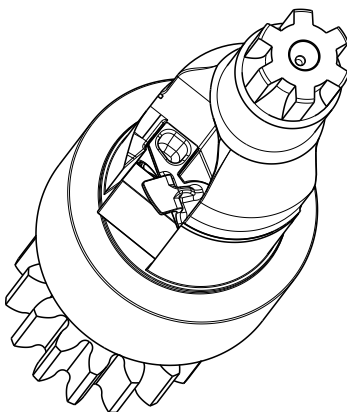

Fig. 4.2.k

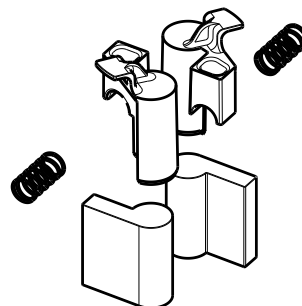

Fig. 4.2.l

10. Reassemble the winch in reverse order of dismantling. Adjust the self tailing arm so it guides the line into the cockpit or preferred direction.

4.3 Service instructions

1. Dismantle the winch according to the steps 4.1.
2. Clean all surfaces before lubricating using a dry cloth or white spirit.
3. Apply a thin layer of grease with a brush at the upper and lower gear ring in the drum.
Use Seldén lubrication grease art.no: 312-501.

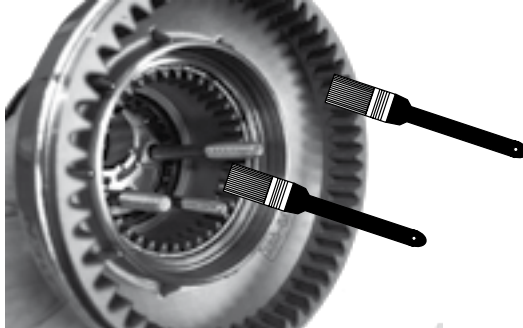

Fig. 4.3.a

4. Lift the shaft which holds the twin gear wheel and lubricate the shaft. Put it back. Lubricate the gear teeth at the twin gear wheel.



Fig. 4.3.b



Any grease should be applied ONLY at these places where it is stated.

DINGHIES KEELBOATS YACHTS

Seldén Mast AB, Sweden
Tel +46 (0)31 69 69 00
Fax +46 (0)31 29 71 37
e-mail info@seldenmast.com

Seldén Mast Limited, UK
Tel +44 (0) 1329 504000
Fax +44 (0) 1329 504049
e-mail info@seldenmast.co.uk

Seldén Mast Inc., USA
Tel +1 843-760-6278
Fax +1 843-760-1220
e-mail info@seldenus.com

Seldén Mast A/S, DK
Tel +45 39 18 44 00
Fax +45 39 27 17 00
e-mail info@seldenmast.dk

Seldén Mid Europe B.V., NL
Tel +31 (0) 111-698 120
Fax +31 (0) 111-698 130
e-mail info@seldenmast.nl

Seldén Mast SAS, FR
Tel +33 (0) 251 362 110
Fax +33 (0) 251 362 185
e-mail info@seldenmast.fr

**Seldén Mast Asia Ltd,
Hong Kong**
Tel +852 3572 0613
Fax +852 3572 0623
e-mail info@seldenmast.com.hk

www.seldenmast.com

Dealer:

The Seldén Group is the world's leading manufacturer of mast and rigging systems in carbon and aluminium for dinghies, keelboats and yachts.

Our well known brands are Seldén and Furlex. The worldwide success of Furlex has enabled us to build a network of over 750 authorised dealers covering the world's marine markets. So wherever you sail, you can be sure of fast access to our service, spare parts and know-how.

SELDÉN and FURLEX are registered trademarks of Seldén Mast AB

 **SELDÉN**