

# Assembly of Line-Lock terminals

Both halyard swivel and the lower swivel have line-lock terminals. We recommend assembling them one at a time. Don't cut the anti-torsion cable (AT-cable) until the first terminal assembly is finished. The line lock terminal is designed for AT-cables supplied from Seldén.

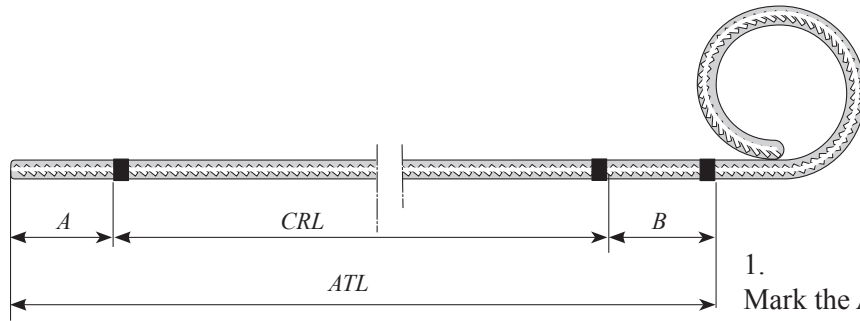

1. Mark the AT-cable with a thin tape in three places according to the dimensions calculated in the calculation table 2.3.

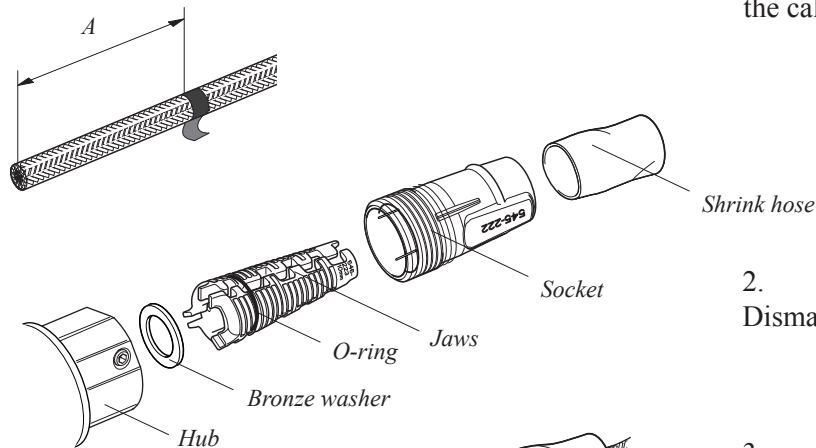

2. Dismantle the line-lock terminal.

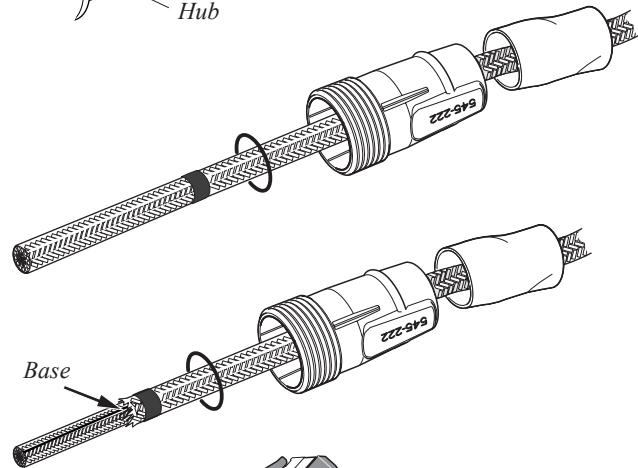

3. Remove the o-ring from the Jaws. Feed the heat shrink hose, socket and the o-ring onto the AT-cable.

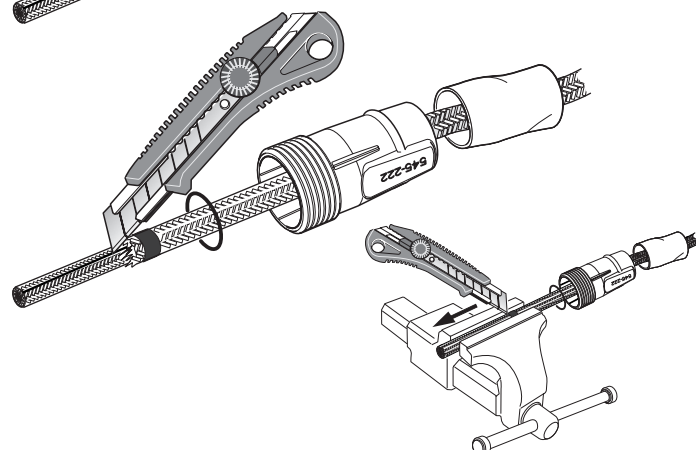

4. Remove the outer cover. Cut with a scissor at the base. Leave the tape in place.

5. Cut the inner cover carefully along the cable, using a utility knife. Avoid cutting into the underlying core. However, small damage is acceptable as the core at this place is stronger than necessary.

Cutting will be easier if the AT-cable is tightened in a vise. Let the clamping jaw guide the utility knife blade.

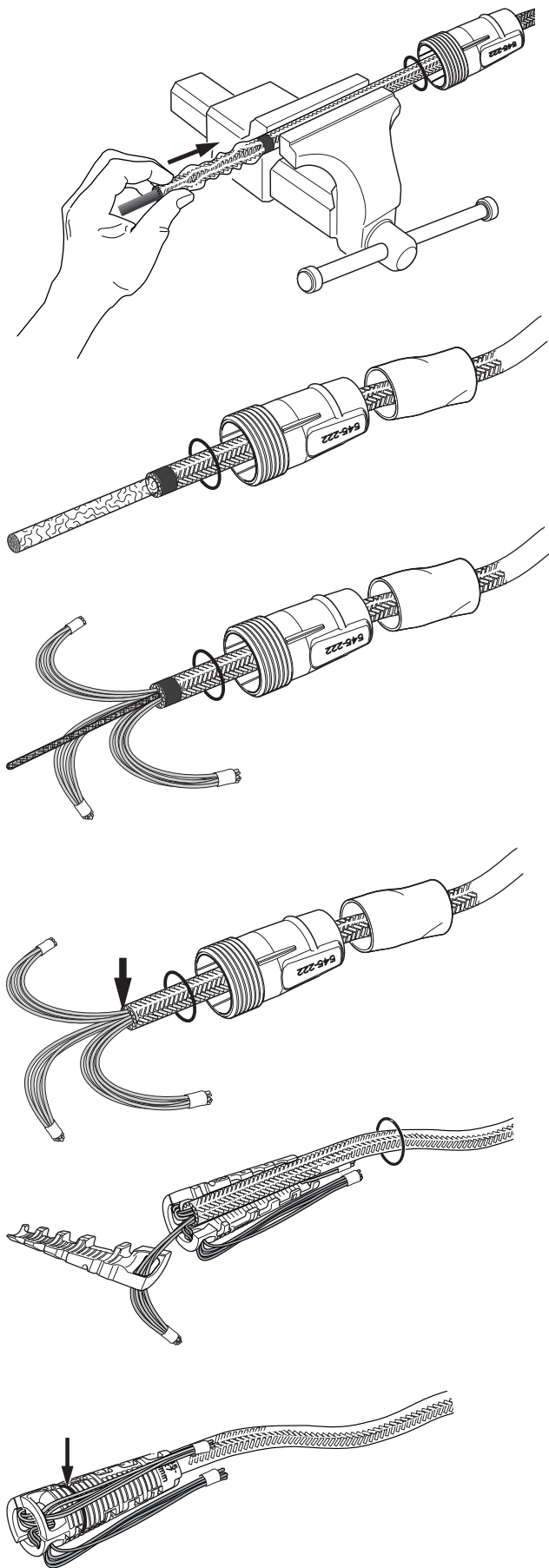

6.  
Push the inner core against the AT-cable to loosen the tightly packed strands.

7.  
Peel off the inner cover from the core. Cut with a scissor at the base.

8.  
Divide the core strands evenly into 3 equal groups. Put a tape onto the 3 ends securing the strands.

9.  
Cut the centre composite rod at the tape level. Remove the tape at the base.

10.  
Feed each core into the hole at the bottom of a jaw. Place the jaws OVER the outer cover at the AT-cable.

11.  
Distribute the jaws evenly onto the AT-cable and lock them in position with the o-ring. The end of the cover on the AT-cable should be hardly visible. The o-ring should be mounted into the groove close to the bottom of the jaws.



**It is extremely important that the jaws are placed according to the instructions so that they will squeeze the outer cover of the AT-cable when the terminal is screwed together.**

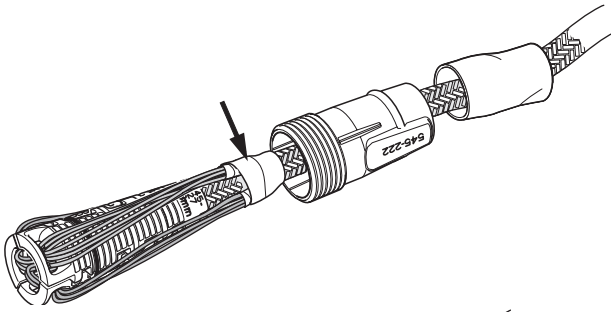

12.  
Pull the three core strands equally and secure them in the shown position with tape.

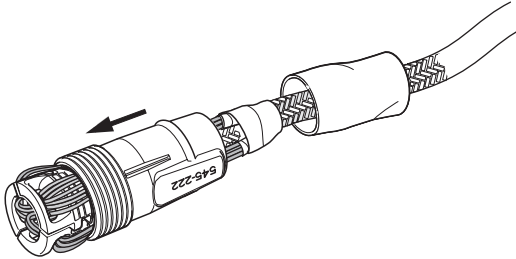

13.  
Push down the socket onto the jaw/strands.

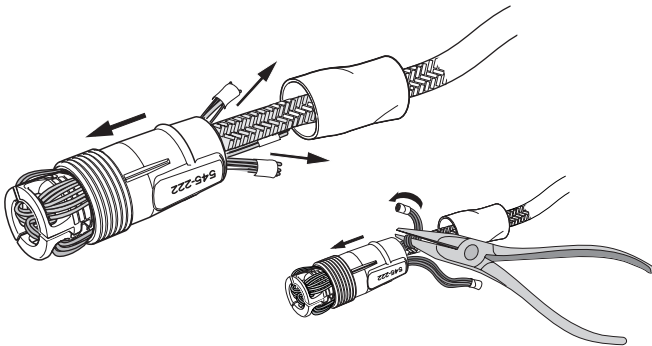

14.  
Remove the last tape, fitted during step 12, and pull the three strand groups evenly while the socket is pressed down over the jaw/strands as hard as possible.

A flat nose pliers can be used to stretch the strands. Tap the jaws into the socket with a hammer.

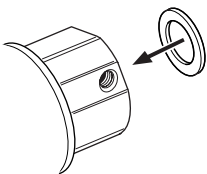

15.  
Place the bronze washer in the bottom of the hub.

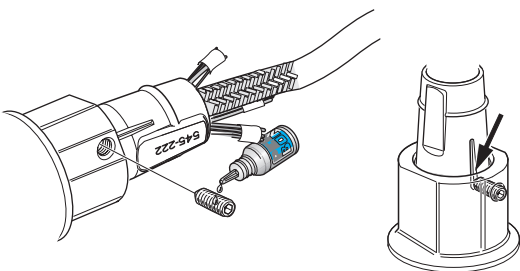

16.  
Fit the assembly to the swivel socket. Tighten the rope-lock terminal hard. Release until the groove in the socket aligns with the grub screws. Apply locking adhesive and tighten the grub screw.

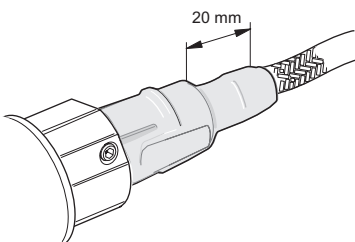

17.  
Cut the residual core strands.

Move the heat shrink hose over the socket and shrink it with a heat gun. Be careful not to melt the AT-cable cover. High quality tape can also be used.