

Mast climbing steps

Foldable and well-rounded, these climbing steps reduce windage and prevent lines from getting tangled. Fit one or two for easier access to the head of the mainsail when attaching the halyard, or all the way up for regular inspection of your rig. Mast climbing steps can be used in addition, but not as an alternative to your normal safety equipment for working aloft.

Operation

- The mast step is only designed for one person.
Maximum load is 140 kg.
- The step is spring loaded to prevent rattling and accidental opening.
- To open; lift lugs, **A** and fold out.
or
Unfold the plate by pushing it at point **B**.
This can be done with with the hand or the foot.

These instructions do not apply to carbon spars. Before mounting, please consult your mast manufacturer.

Mounting Instruction 508-077-01

1. For mast climbing, the distance between the steps is chosen individually. Seldén's standard placement is 420 mm apart.
2. Hold the mast step in position and mark the three holes.
The step level is 30mm above lower attachment hole.
3. Drill holes with $\varnothing 5\text{mm}$ drill bit and tap M6.
4. Apply locking adhesive to the screws and fit the mast step firmly, do not overtighten.
The two top screws can only be fitted when the mast step is opened.

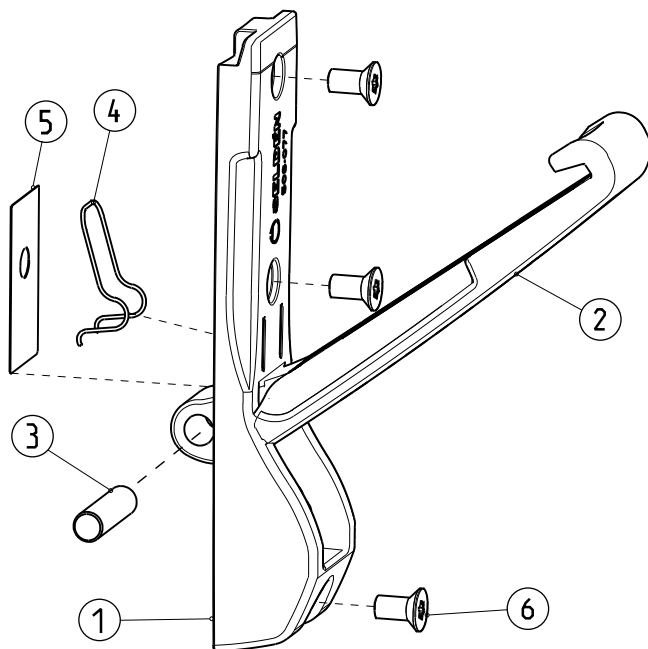
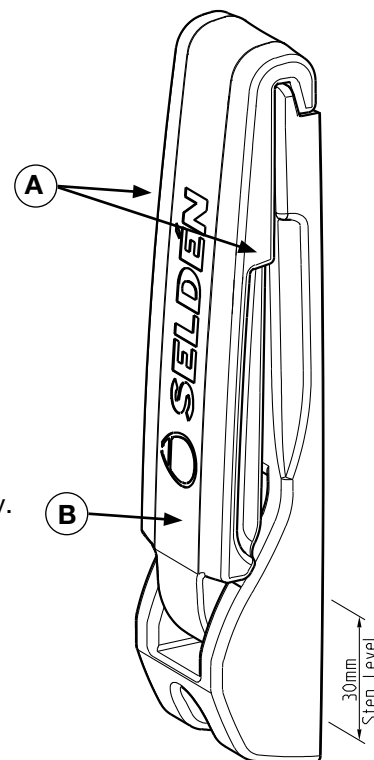

Item	Description	Part No.
1	Base	508-077
2	Step	508-078
3	Pin	172-008
4	Spring	166-517
5	Tape patch	530-617
6	Screw MFT M6x12	162-030



Important - Always use a harness when working aloft.
Viktigt - Använd alltid säkerhetssele vid arbete i masten.
Aschtung - Benutzen Sie einen Sicherheitsgurt, wenn sie im Mast arbeiten.
Ricordate - Usare sempre una sicurezza quando lavorate in testa.
Recuerda - Utiliza un arnés de seguridad siempre que trabajes subido en el mastil.
Rappelez-Vous - Utilisez toujours un harnais de sécurité lorsque vous travaillez dans la mature.