

# Furlex H

(Hydraulic)



With a Furlex Hydraulic, the cruise control is complete. All you need to do is press a button in the cockpit and adjust the sheet.

The Furlex Hydraulic is designed to provide a harmonious visual interplay of stainless steel and aluminium. The hydraulic motor is located inside the worm gear, in the same way as it is with the furling mast system. The positioning of the motor contributes to the compact design of the Furlex Hydraulic.

Type	Forestay dia., mm	Max. forestay length, m	Motor designation	Art. No.			
300H	8	15.5	OML 12.5	039-027-70			
		17.9		039-027-71			
	10	15.5	OML 12.5	039-027-72			
		17.9		039-027-73			
400H	12	20.3	OML 12.5	039-027-74			
		17.7		OML 20	049-034-75		
		20.1			049-034-76		
	22.5	049-034-77					
	14	17.7	20.1	OML 12.5	049-034-95		
					22.5	049-034-96	
		20.1	22.5	OML 20	049-034-97		
					20.1	OML 12.5	049-034-78
					22.5		049-034-79
		500H	16	20.1	OML 20	049-034-98	
22.5				049-034-99			
-60 rod	23.0		OMM 20	060-046-50			
	27.8			060-046-51			
	27.8			060-046-70			
	32.6			060-046-71			
-40 rod	23.0	OMM 20	060-046-80				
	27.8		060-046-81				
	27.8		060-046-81				
	23.0		060-046-90				
-48 rod	27.8	OMM 20	060-046-91				
	32.6		060-046-92				



Furlex Hydraulic, deck gland and deck gland protection.



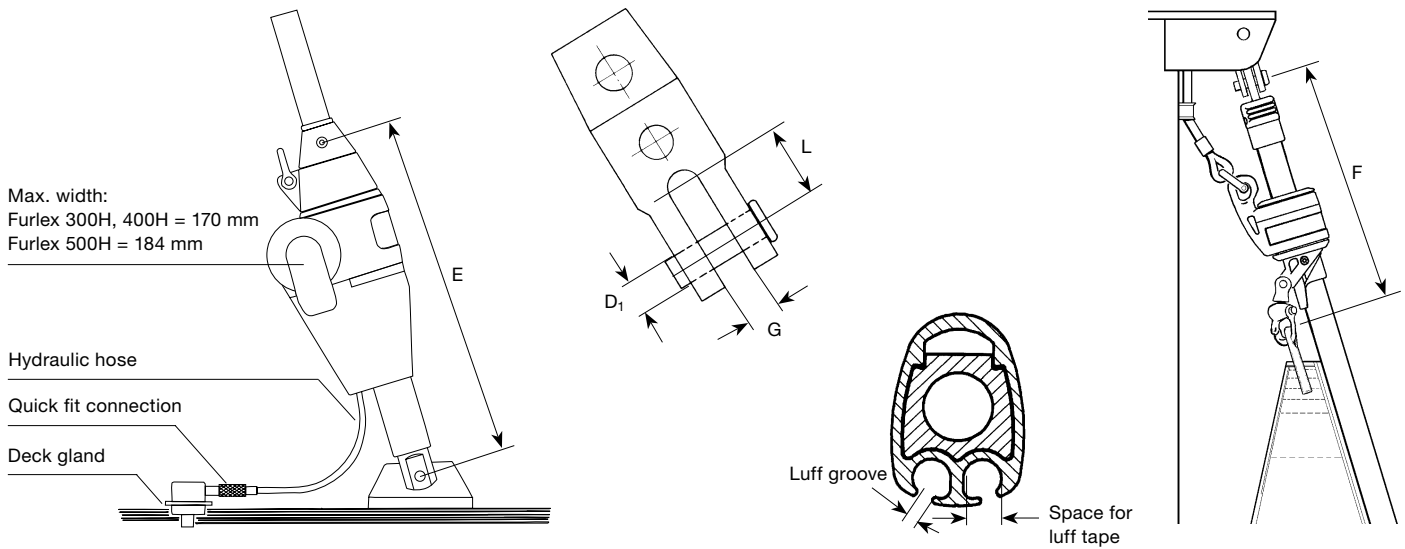

## Furlex Hydraulic specifications

Type	Total weight drive unit, kg	Luff extrusion kg/m	Halyard swivel, kg	Extrusion dim., mm	Luff groove mm	Max space for luff tape, dia., mm	Max. luff tape dia., mm	"Cut-Back" mm
300H	16	0.76	1.7	40 x 27	3.0	7	6	80
400H	25	1.06	3.3	50 x 34	3.0	8	6	100
500H	37	1.93	7.0	60 x 46	3.0	9	7	100

Type	Forestay wire dia., mm	Rod dia. mm	Nav-tec	OYS* (Riggarna)	BSI	Max RM (kNm) at 30° heel		Clevis dia., mm	G mm	L mm	E mm	F mm	Forestay adjustment
						Masthead	Fractional						
300H	8	-12 (7.1)	X		X	40	50	14	15	30	490	540	100
		-15 (7.5)		X	X								
	10	-17 (8.4)	X		X	70	80	16	15	30			
-22 (9.5)		X	X	X									
400H	12	-30 (11.1)	X	X	X	120	160	19	19	35	610	620	110
		-30 (11.1)	X										
	14	-40 (12.7)	X	X	X	180	190	22	23	40			
500H	16	-				230	250	25.4	26	45	675		100
		-40 (12.7)	X	X		180	190	25.4	26	45			
		-48 (14.3)	X	X	X	230	250	28.6	29	50			
		-60 (16.8)	X	X	X	330	-	31.8	32	55			

\* The upper eye terminal must be of the MNY type.

Type	Motor designation	Max. torque at max. pressure, Nm	Nominal speed luff extrusion (n), rpm	Nominal oil flow (Q), l/min	Nominal oil pressure (p), bar	Max. oil pressure (p), bar	Rec. min. power hydraulic, pack (P) kW	Max. sail area m <sup>2</sup>
300H	OML 12.5	158	40	10	40	140	1.5	80
400H	OML 12.5	175	40	10	40	140	2.0	125
400H	OML 20.0	255	40	20	40	140	3.0	150
500H	OML 20.0	290	40	20	40	140	4.0	200